

PLAYGROUND SPIELPLATZ

PLAC ZABAW AIRE DE JEUX

(390 x 253 x h305cm)

003_03295_27042021

MY SIDE

INSTALLATION INSTRUCTIONS
MONTAGEANLEITUNG

INSTRUKCJA MONTAŻU
GUIDE D'INSTALLATION

Warranty period - 2 years from purchase date

Garantiezeit - 2 Jahre ab Kaufdatum

Okres gwarancji - 2 lata od momentu zakupu towaru

Période de garantie - 2 ans à compter de l'achat

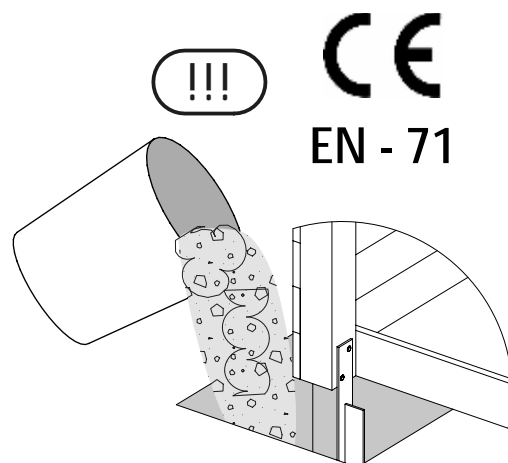
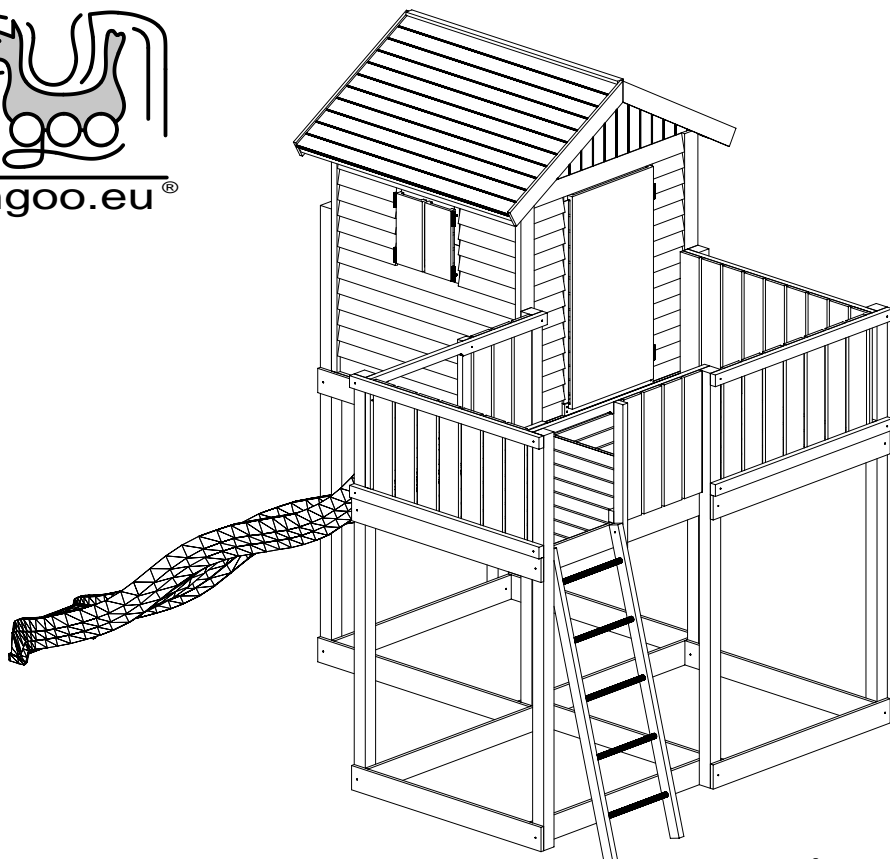

WARNINGS!

Only for home use.

Dedicated for external use only.

Not suitable for children under 3 years old.

Risk of falling down and/or hitting.

Maximum user weight is up to 50 kg.

Maximum number of users staying on the
playground at the same time: 9.

OSTRZEŻENIA!

Tylko do użytku domowego.

Przeznaczony do użytku na zewnątrz.

Nie przeznaczony dla dzieci poniżej 3 roku życia.

Niebezpieczeństwo upadku i/lub uderzenia.

Maksymalna waga użytkownika to 50 kg.

Maksymalna liczba użytkowników przebywających
na placu zabaw w tym samym czasie: 9.

ACHTUNG!

Nur für den privaten, häuslichen Bereich.

Ausschließlich für die Verwendung im Freien.

Nicht geeignet für Kinder unter 3 Jahren.

Stolper- und / oder Sturzgefahr

Höchstgewicht pro Einzelkind beträgt 50 kg

Der Aufenthalt auf diesem Spielturm ist max. : 9.

Kindern gleichzeitig erlaubt.

AVERTISSEMENT!

Aire exclusivement destinée à un usage privé.

Aire exclusivement destinée à un usage en extérieur.

Prévue pour les enfants de plus de 3 ans.

Danger de chute ou de choc.

Poids maximal d'un utilisateur : 50 kg.

Nombre maximal d'utilisateurs présents en
même temps sur la même aire de jeux: 9.

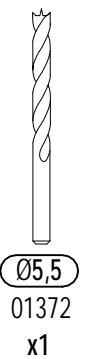
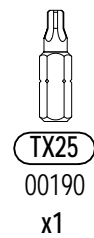
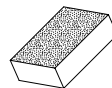
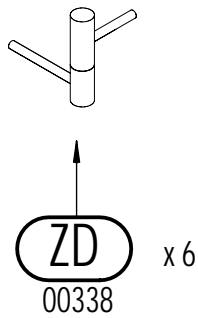
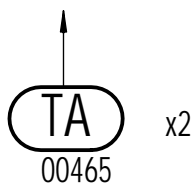
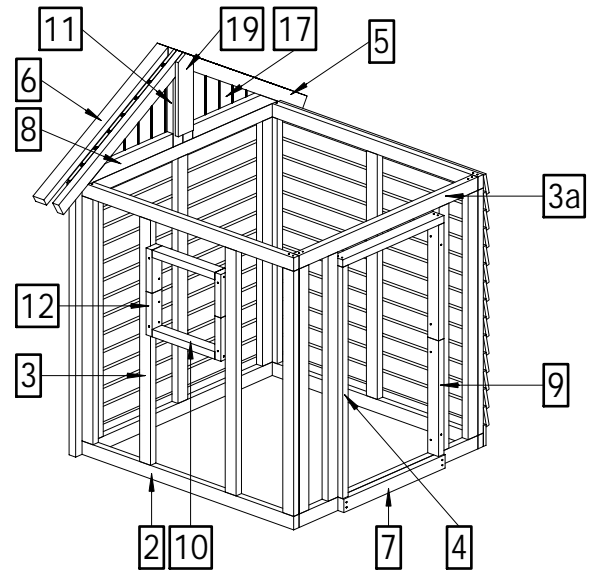
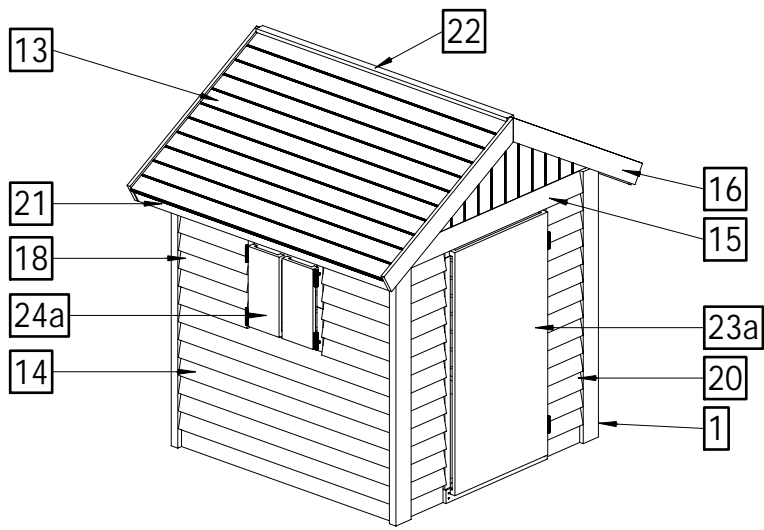

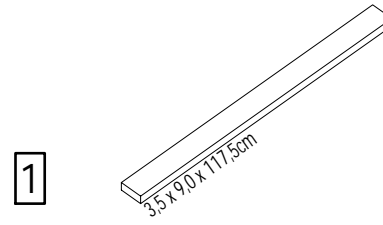

1

7a

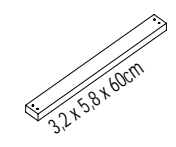

14

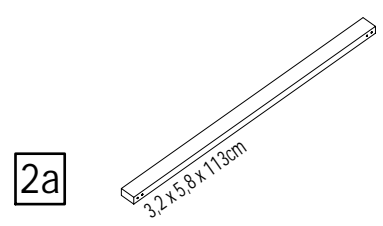
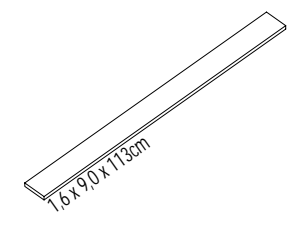

2a

9a

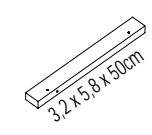

15

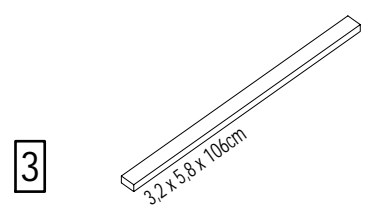
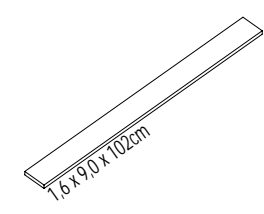

3

10

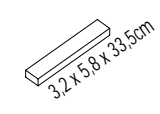

16

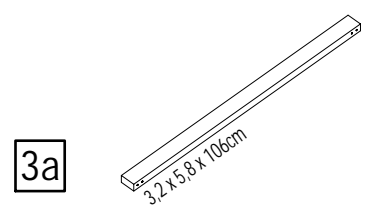
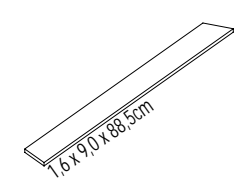

3a

12a

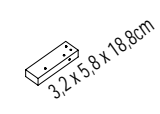

17

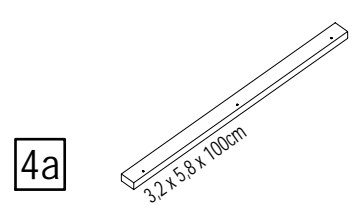
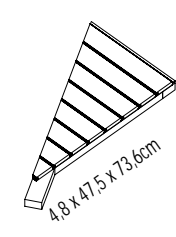

4a

13

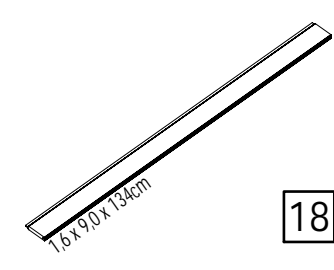

18

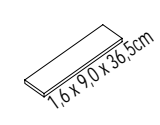

21

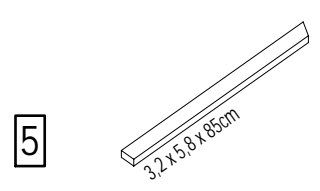
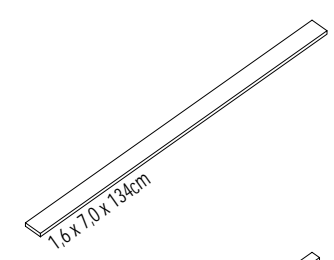

5

19

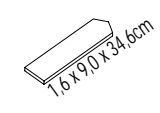

22

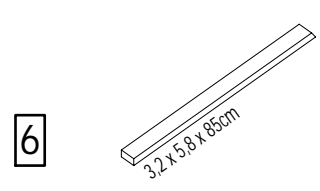
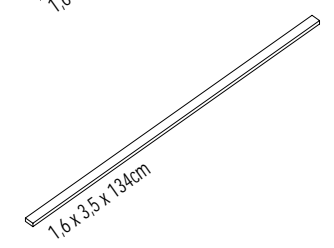

6

20

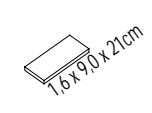

23a

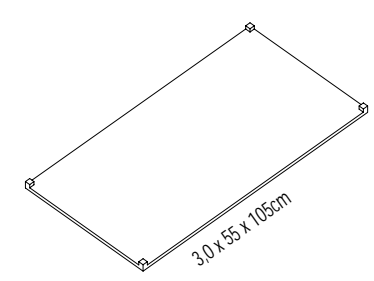

24a

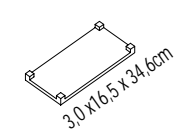

H-1	35x90x1175mm	4
H-2a	32x58x1130mm	4
H-3	32x58x1060mm	14
H-3a	32x58x1060mm	4
H-4a	32x58x1000mm	1
H-5	32x58x850mm	2
H-6	32x58x850mm	4
H-7a	32x58x600mm	2
H-9a	32x58x500mm	2
H-10	32x58x335mm	2
H-12a	32x58x187mm	4
H-13	16x90x1340mm	22
H-14	16x90x1130mm	25
H-15	16x90x1020mm	18
H-16	16x90x885mm	4
H-18	16x90x365mm	10
H-19	16x90x345mm	2
H-20	16x90x210mm	28
H-21	16x70x1340mm	2
H-22	16x35x1340mm	1
H-23a	15x55x1050mm	1
H-24a	15x165x345mm	2
H-17	pólszczyt	4

W80 x239
+1 Gratis



W40 x723
+7 Gratis



W30 x2

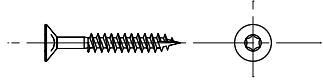

W20 x12



T80 x58

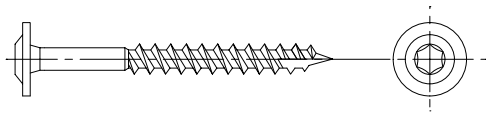

T60 x24

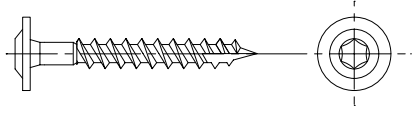

S50 x12

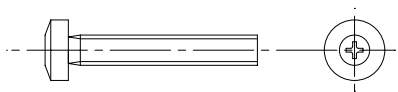

L11 x12

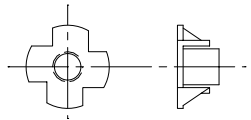

P17 x22

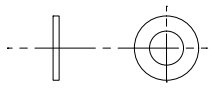

OS1 x60
+4 Gratis

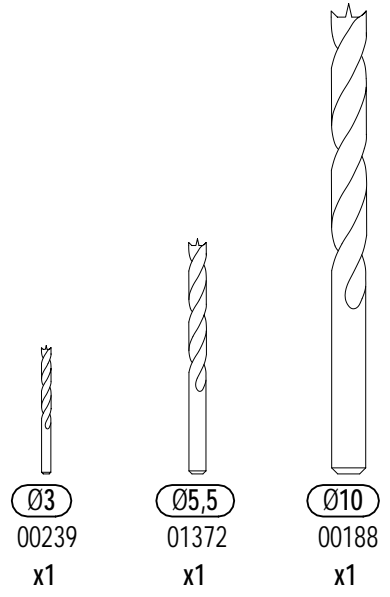
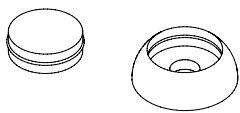

Ø3
00239
x1

Ø5,5
01372
x1

Ø10
00188
x1

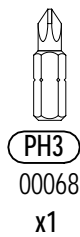

PH3
00068
x1

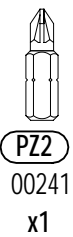

PZ2
00241
x1

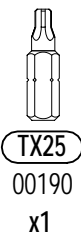

TX25
00190
x1

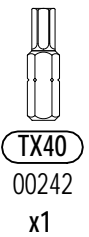

TX40
00242
x1

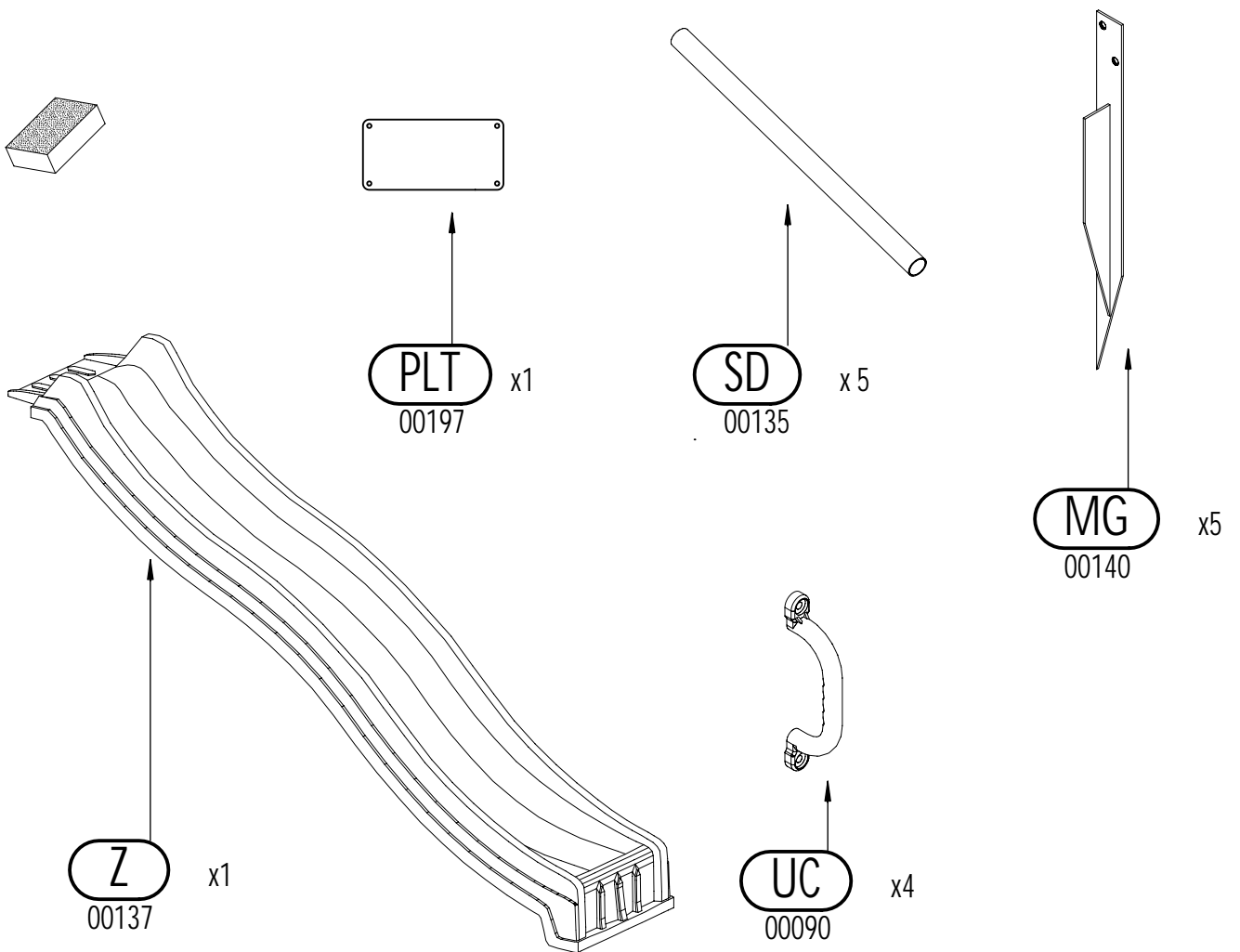
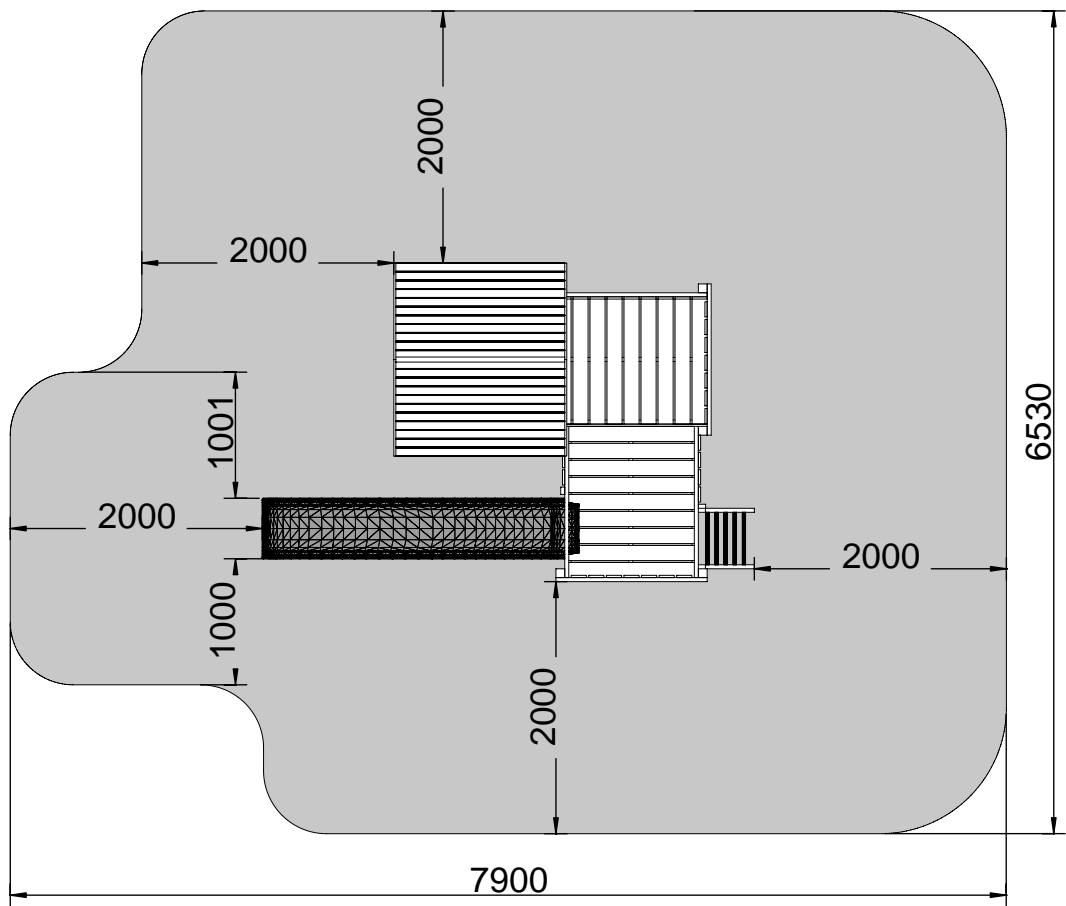

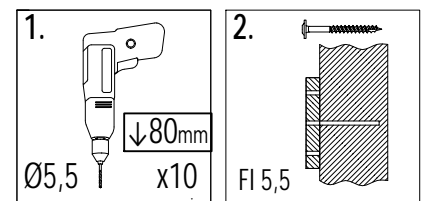
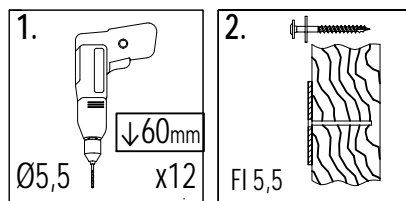
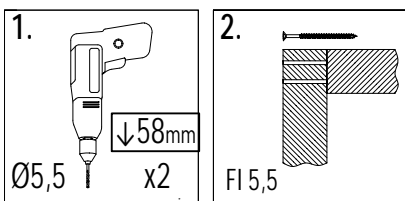
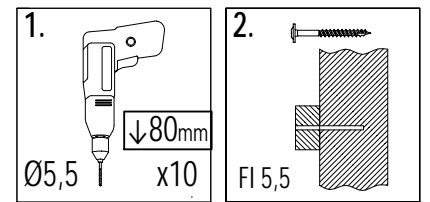
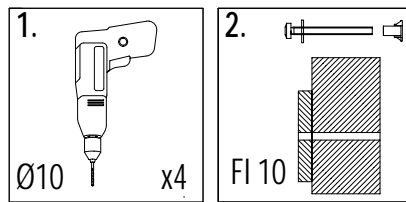
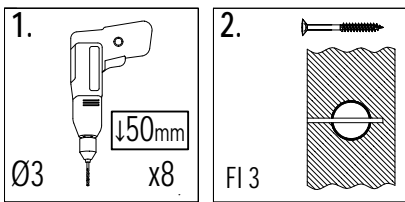
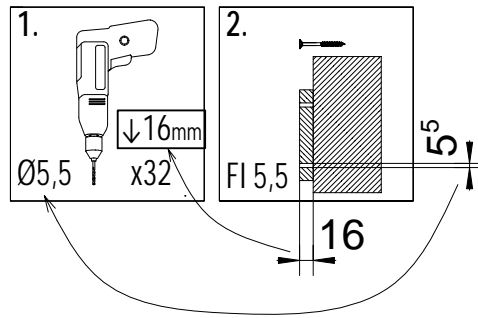
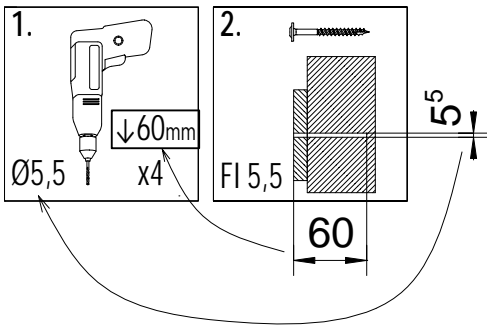
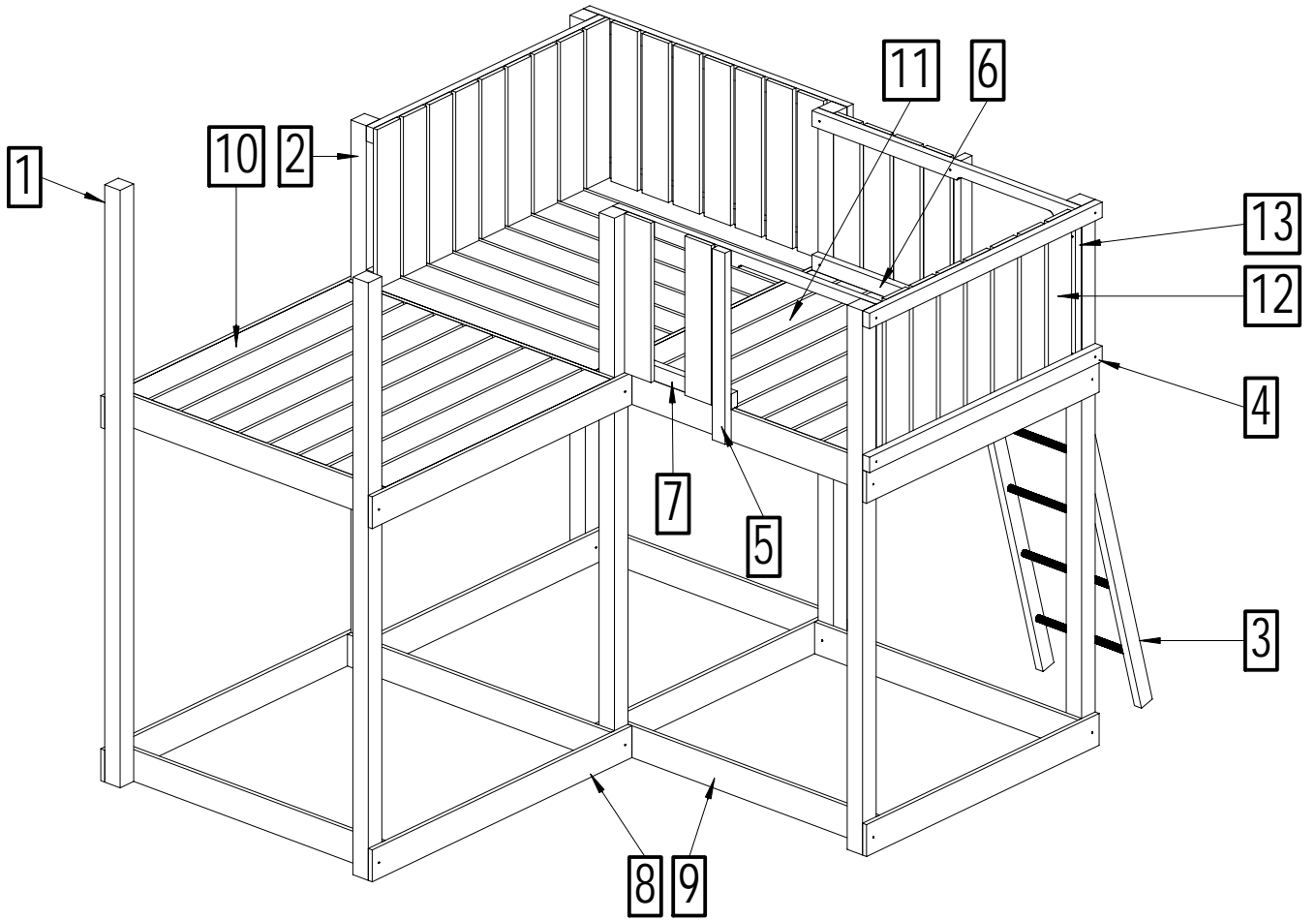

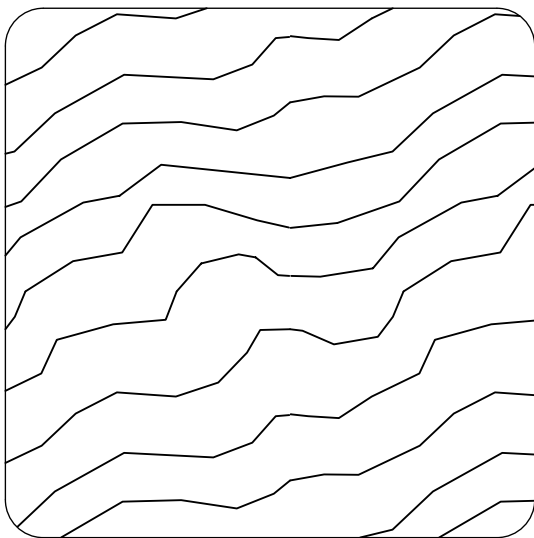

7,0 x 7,0 cm

Lp.	Wymiary [mm]	szt.
P-1	70x70x2250mm	2
P-2	70x70x2050mm	6

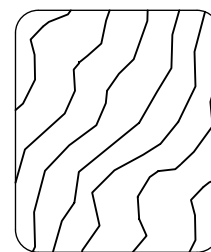

2,7 x 3,2 cm

Lp.	Wymiary [mm]	szt.
P-13a	27x32x542mm	2

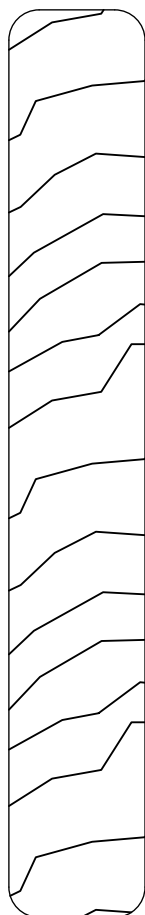

1,8 x 12,0 cm

Lp.	Wymiary [mm]	szt.
P-8a	18x120x1340mm	4
P-9a	18x120x1200mm	16
P-10	18x120x1164mm	9
P-11	18x120x1024mm	18
P-12	18x120x600mm	30

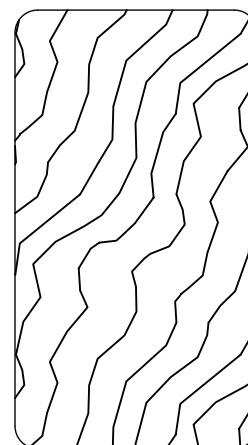

3,2 x 5,8 cm

Lp.	Wymiary [mm]	szt.
P-3a	32x58x1500mm	2
P-4	32x58x1200mm	9
P-4a	32x58x1200mm	4
P-4b	32x58x1200mm	2
P-4c	32x58x1200mm	1
P-4d	32x58x1200mm	1
P-5	32x58x720mm	2
P-6a	32x58x650mm	1
P-7a	32x58x540mm	1

P-1

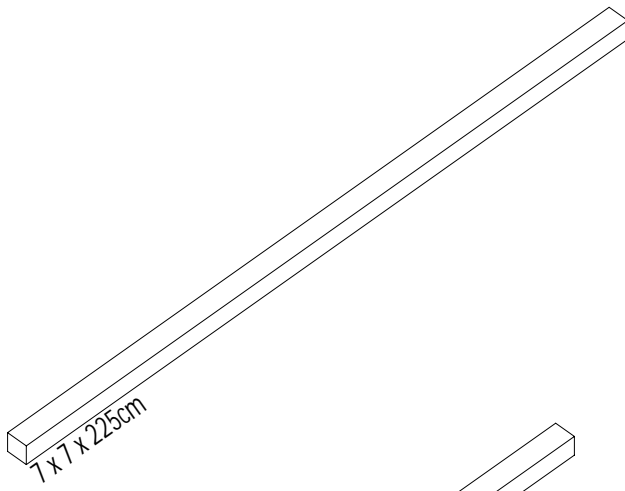

P-2

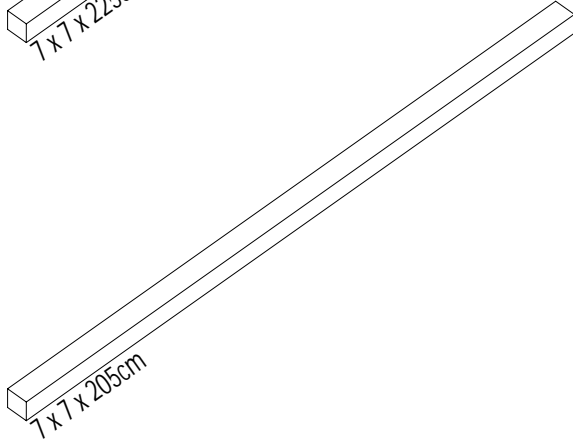

P-3a

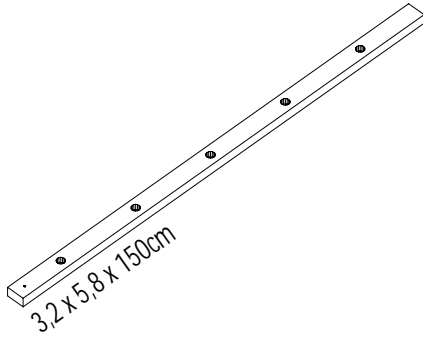

P-4

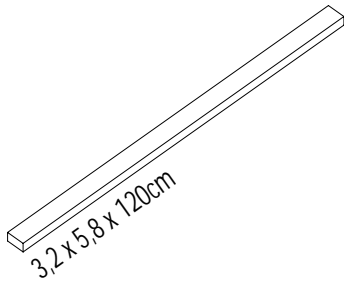

P-4a

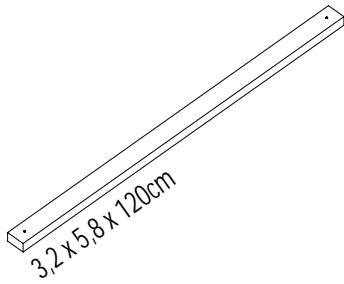

P-4b

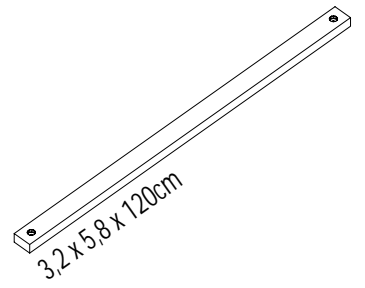

P-4c

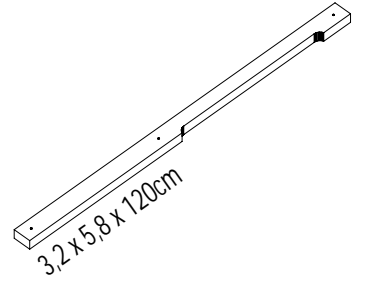

P-4d

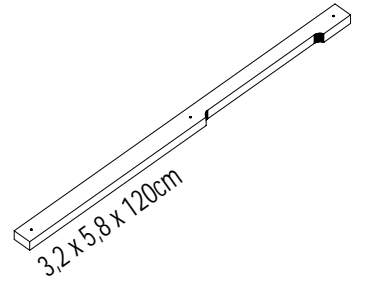

P-5

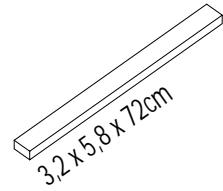

P-6a

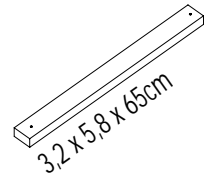

P-7a

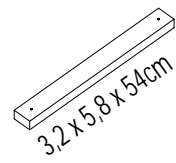

P-8a

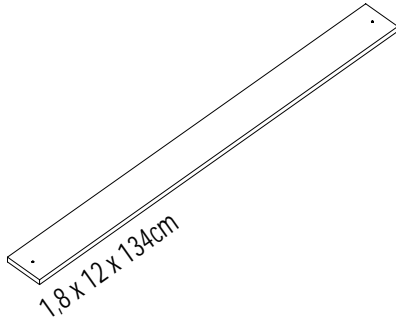

P-13a

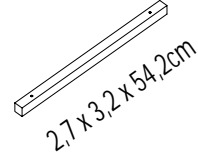

P-9a

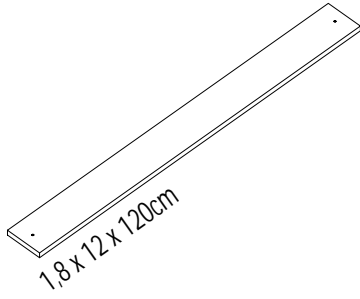

P-10

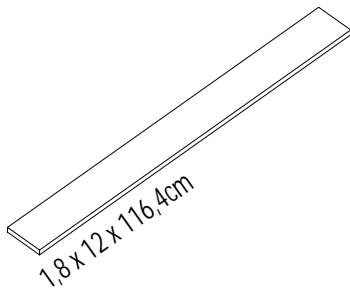

P-11

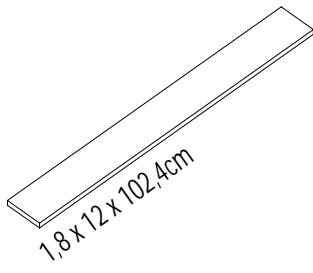

P-12

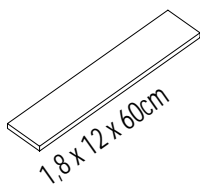

01

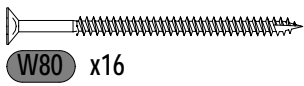
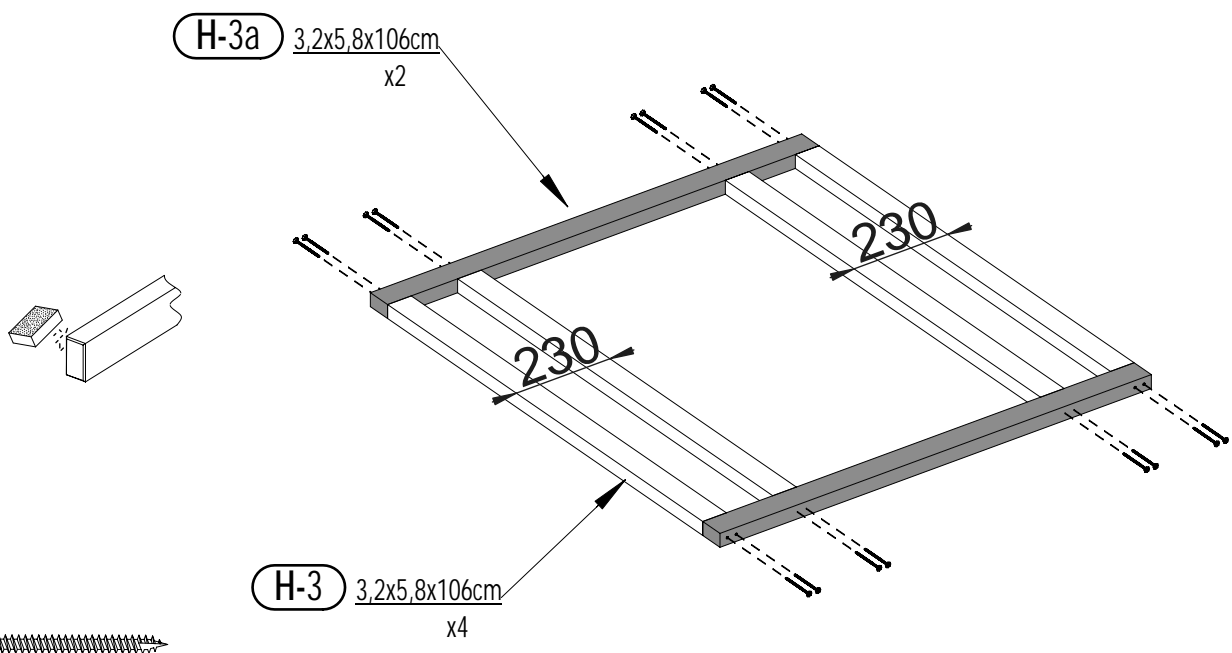
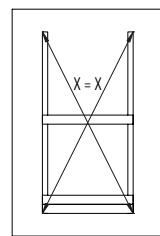
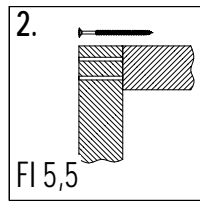
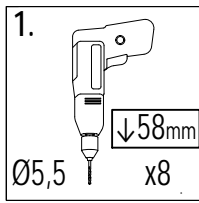

02

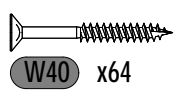
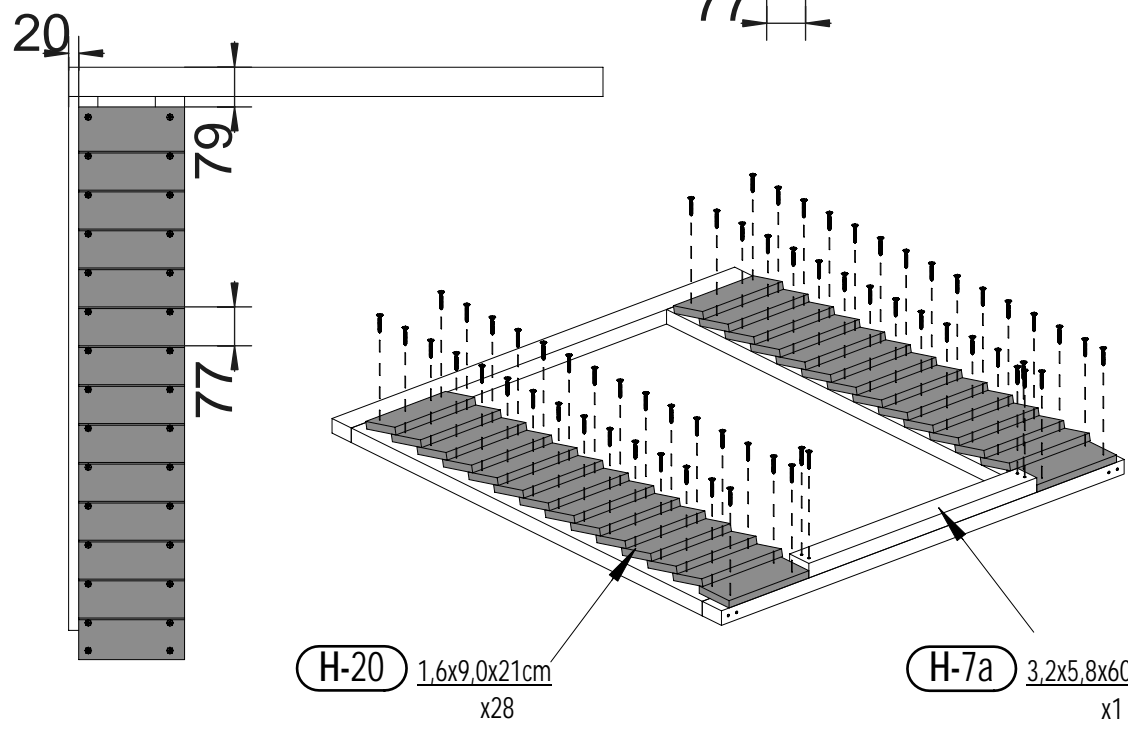
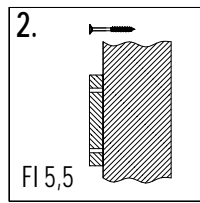
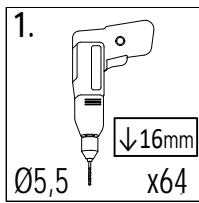

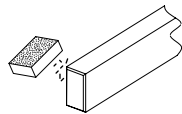
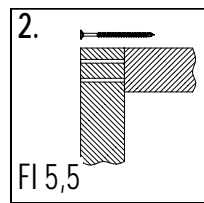
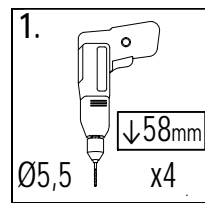
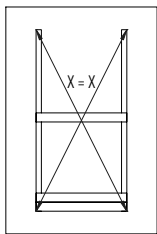

H-3a 3,2x5,8x106cm x2

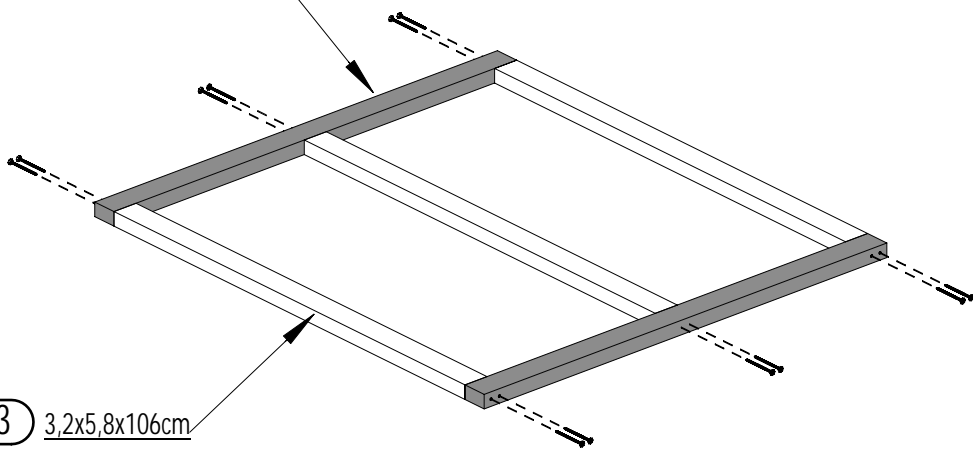

H-3 3,2x5,8x106cm x3

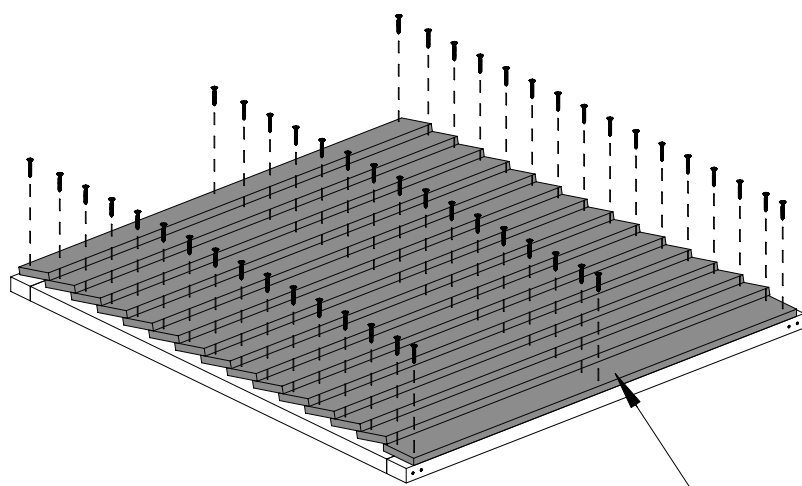
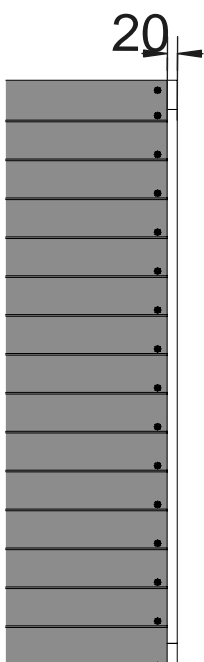
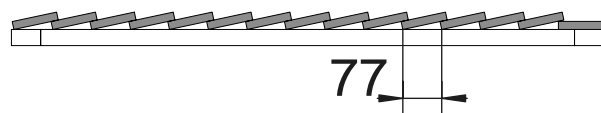
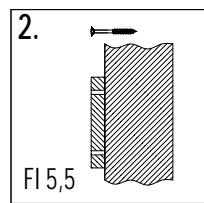
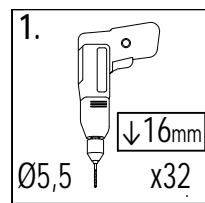
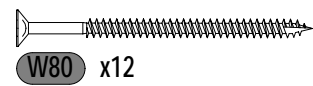

H-15 1,6x9,0x102cm x15

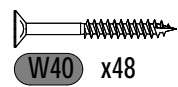
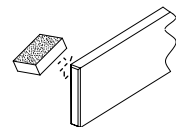

Zgodne z normą PN-EN 71 stosuj zalecenia producenta odnośnie odległości oraz metody mocowania poszczególnych elementów
In compliance with the standard PN-EN 71, apply guidelines of the producer in relation to distances and methods of fastening individual elements

05

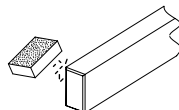
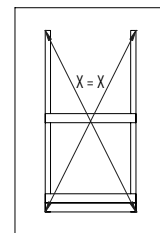
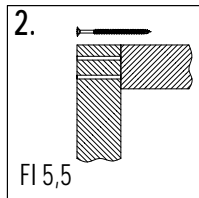
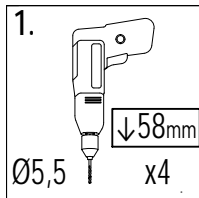

H-2a 3,2x5,8x113cm
 x2

H-3 3,2x5,8x106cm
 x3

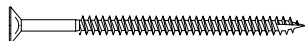
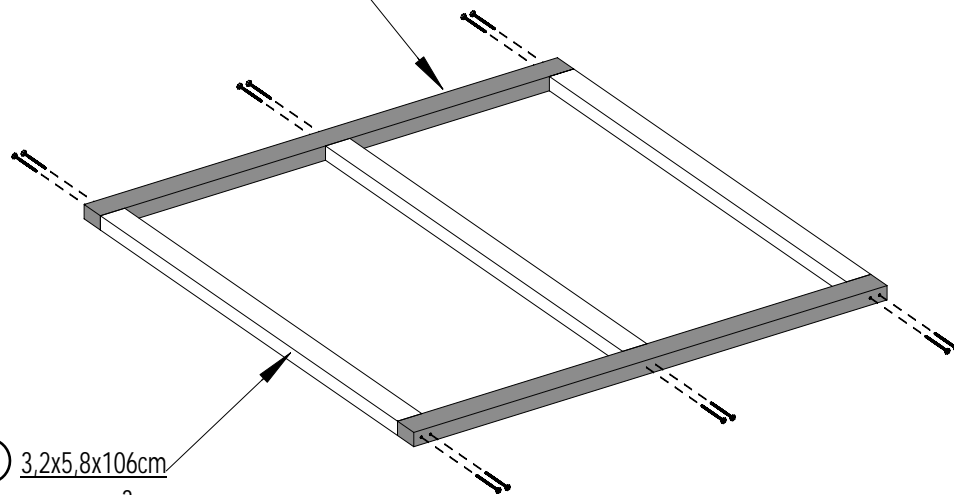

W80 x12

06

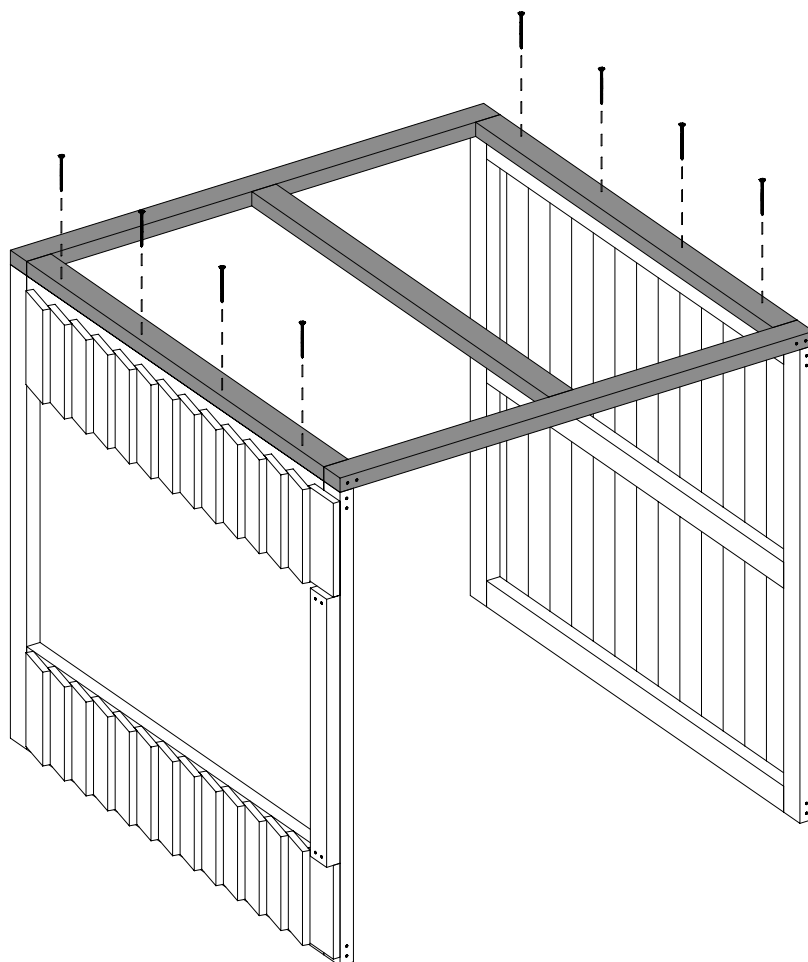
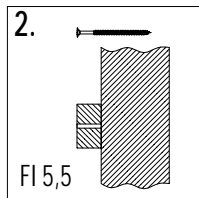
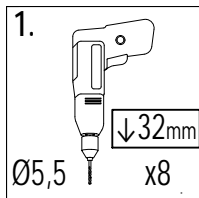

W80 x8

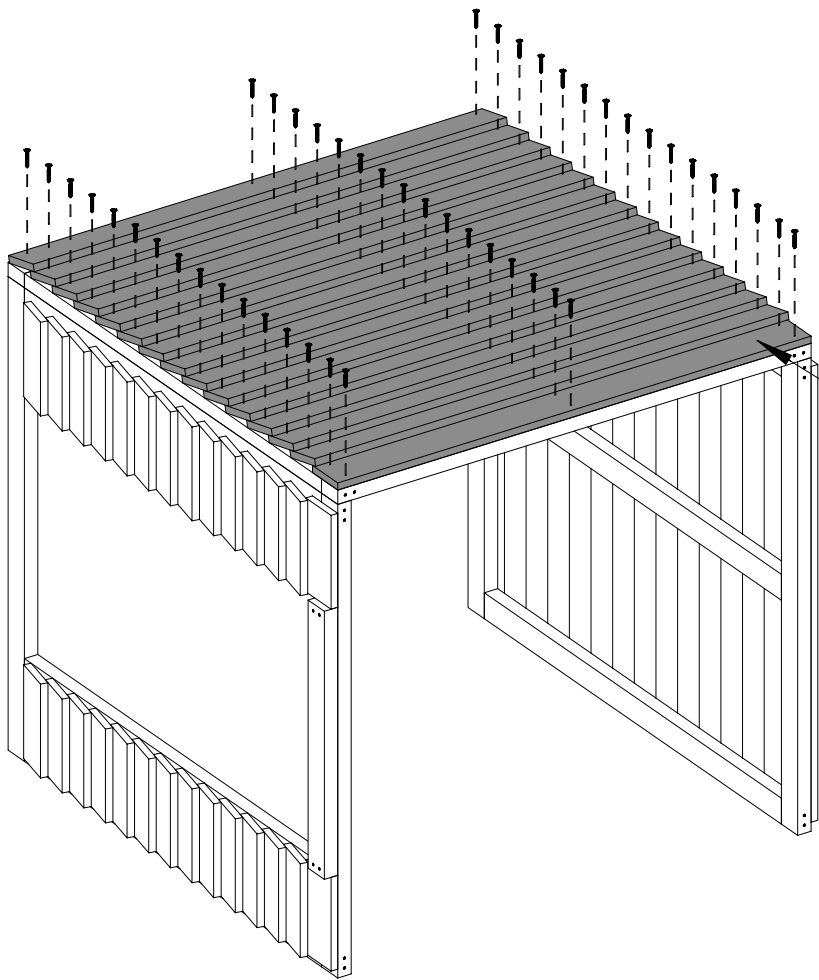

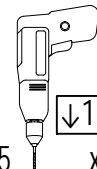
1.  $\downarrow 16\text{mm}$
 $\varnothing 5,5$ x48

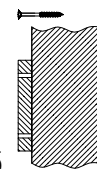
2. 
 FI 5,5

H-14 1,6x9,0x113cm
x15

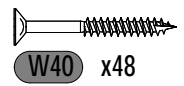
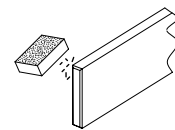

H-2a 3,2x5,8x113cm
x2

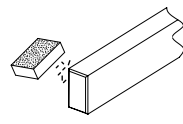

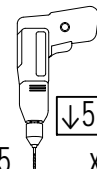
1.  $\downarrow 58\text{mm}$
 $\varnothing 5,5$ x8

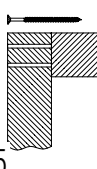
2. 
 FI 5,5

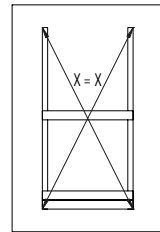
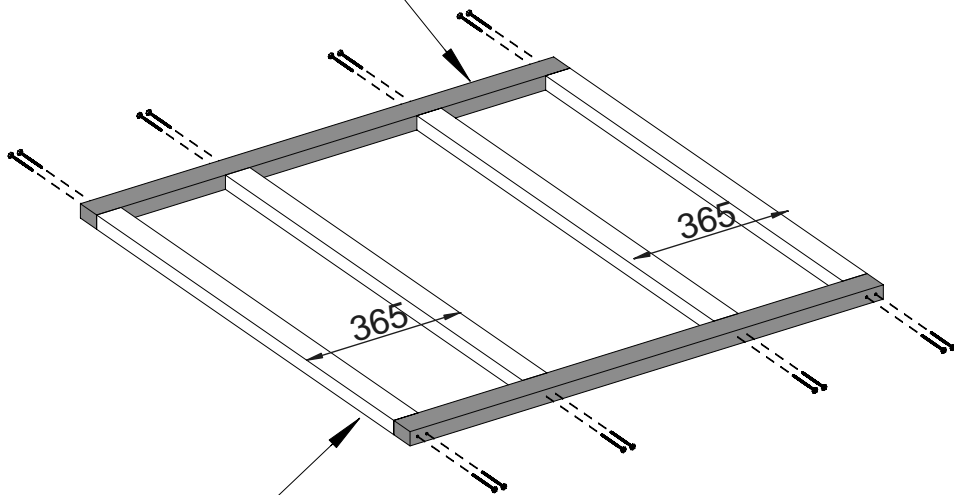

H-3 3,2x5,8x106cm
x4

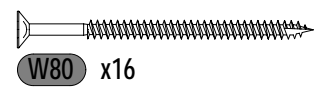

Zgodnie z normą PN-EN 71 stosuj zalecenia producenta odnośnie odległości oraz metody mocowania poszczególnych elementów
 In compliance with the standard PN-EN 71, apply guidelines of the producer in relation to distances and methods of fastening individual elements

09

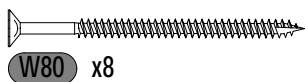
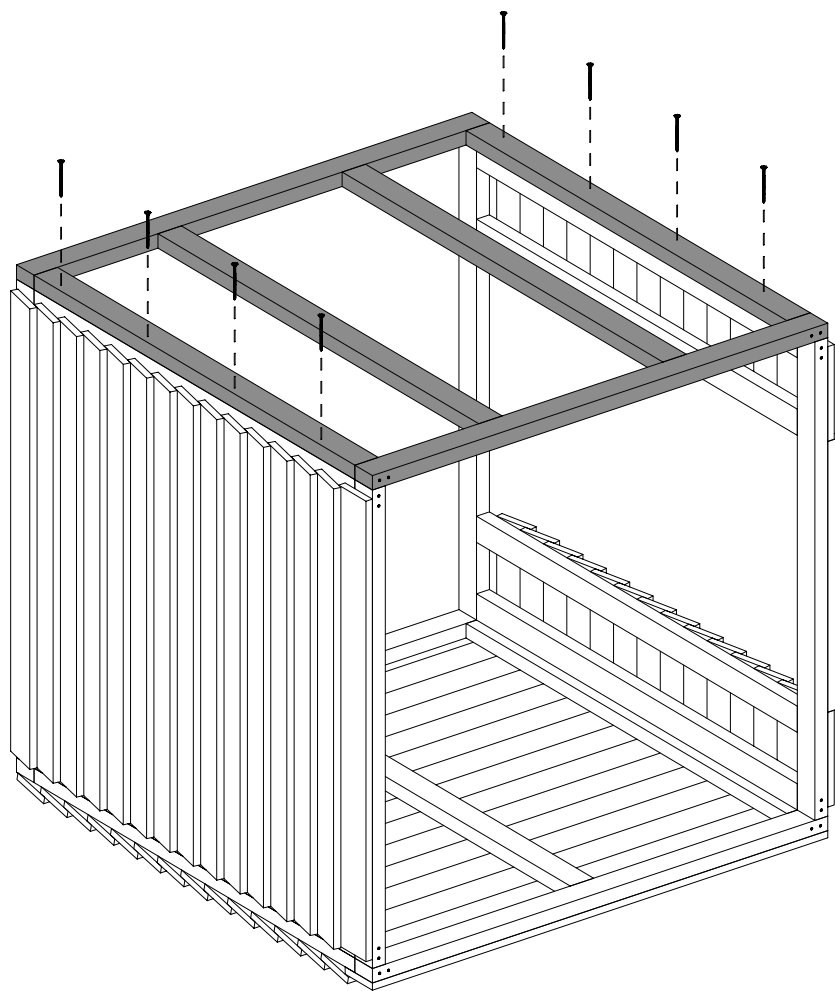
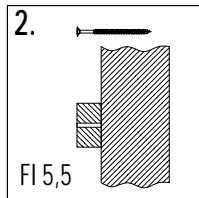
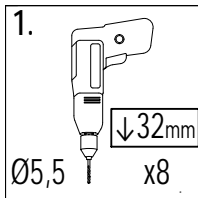

10

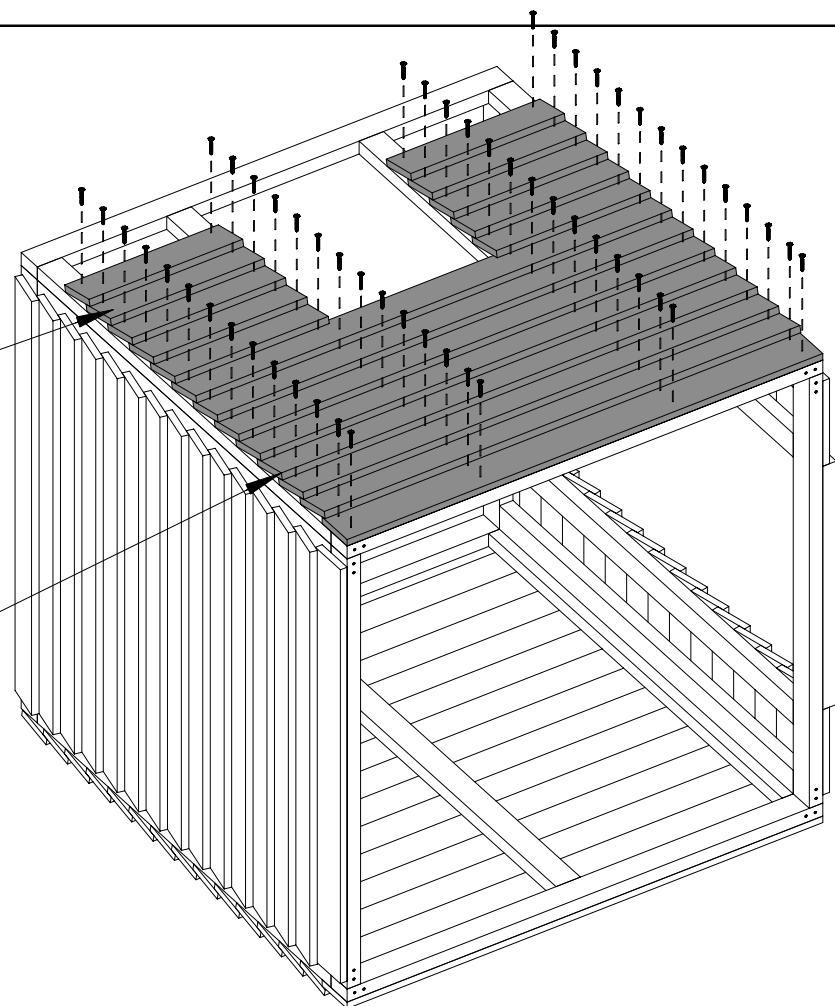
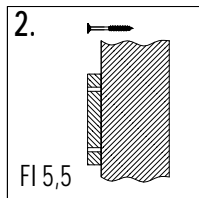
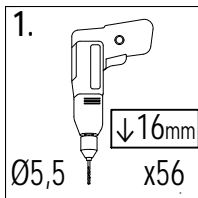

H-18 1,6x9,0x36,5cm
x10

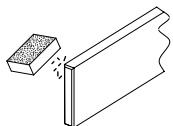

H-14 1,6x9,0x113cm
x8

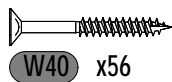

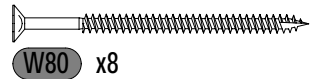
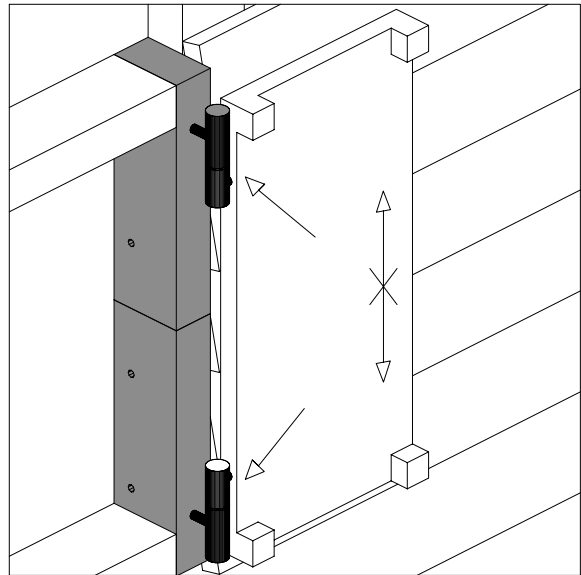
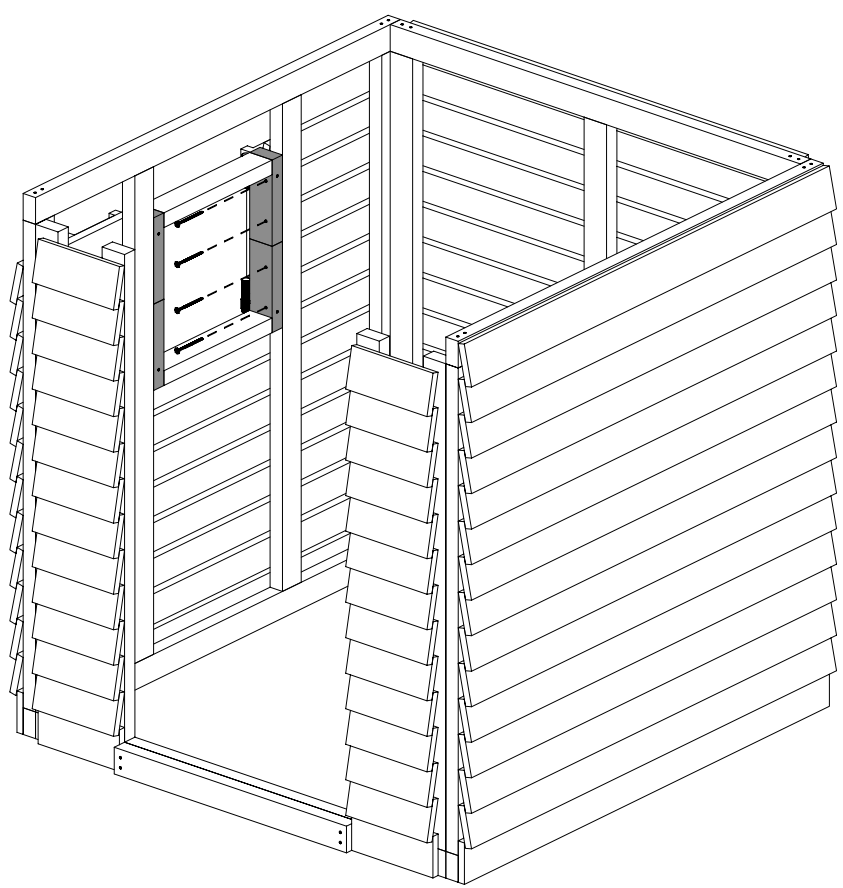
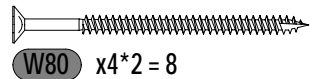
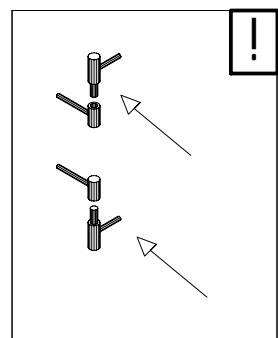
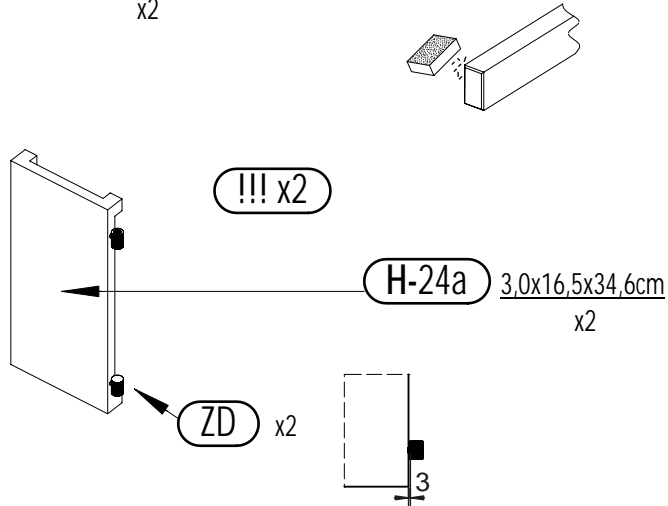
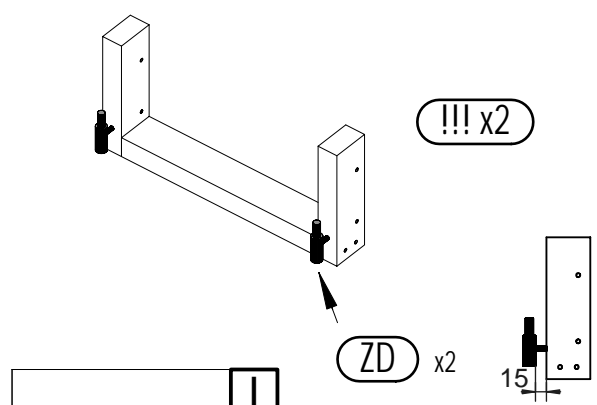
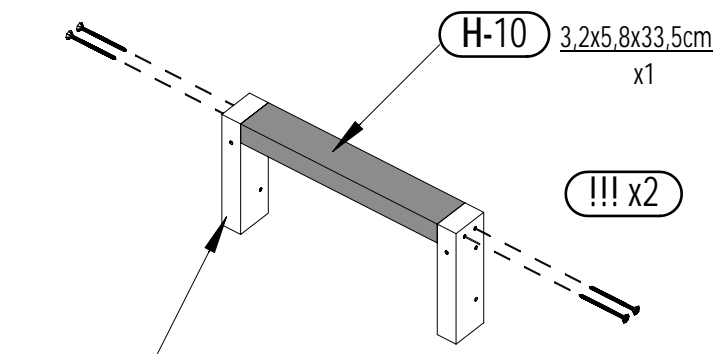

Zgodnie z normą PN-EN 71 stosuj zalecenia producenta odnośnie odległości oraz metody mocowania poszczególnych elementów
 In compliance with the standard PN-EN 71, apply guidelines of the producer in relation to distances and methods of fastening individual elements

13

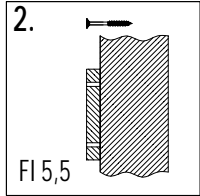
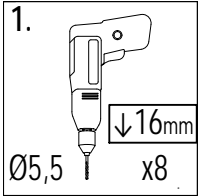

H-13 1,6x9,0x113cm
x2

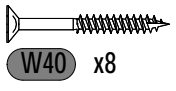
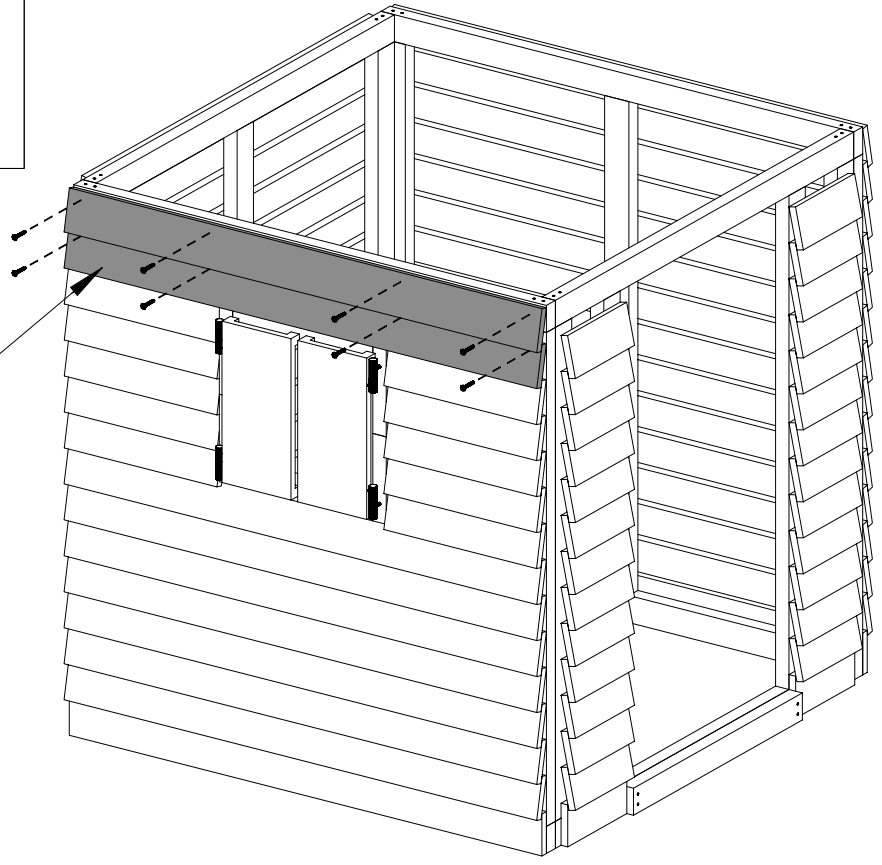
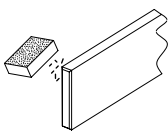

14

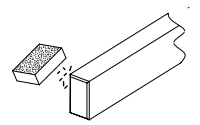
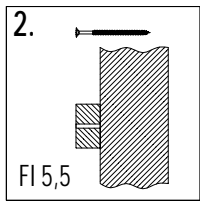
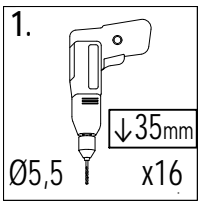

H-1 3,5x9,0x117,5cm
x4

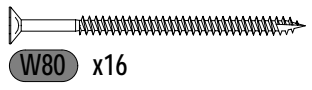
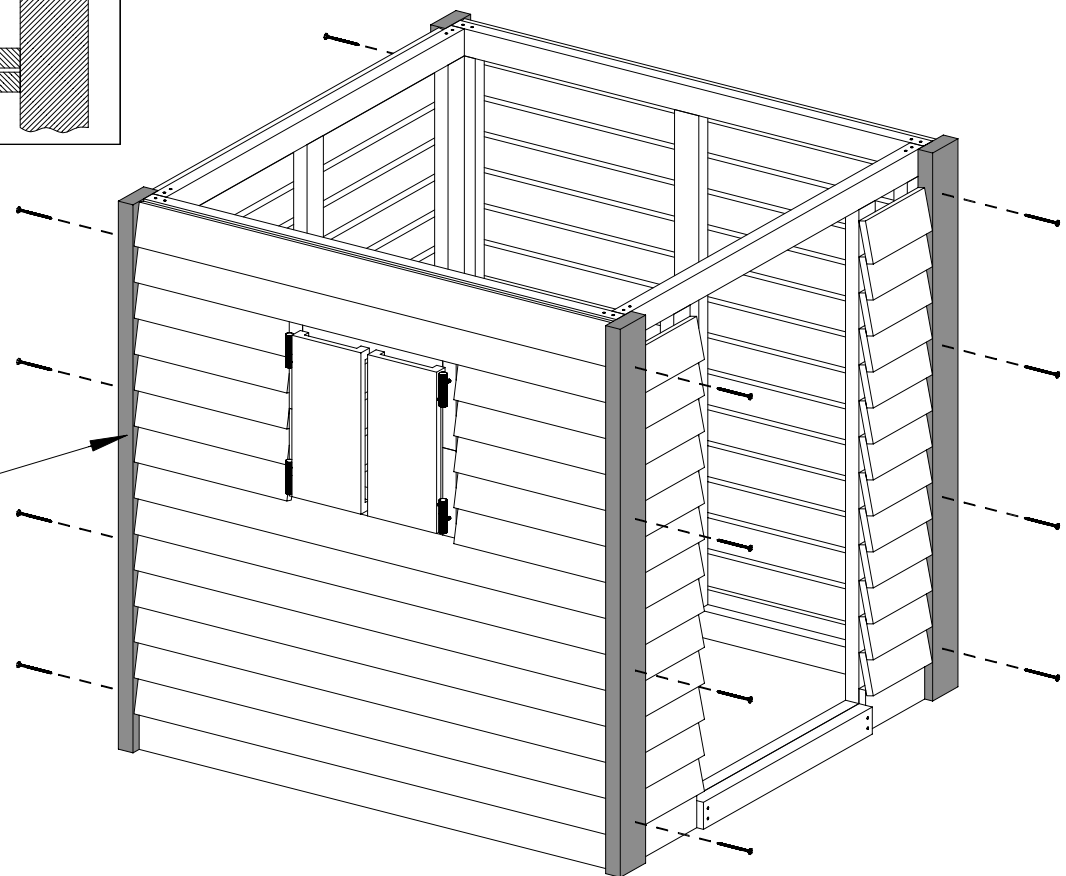

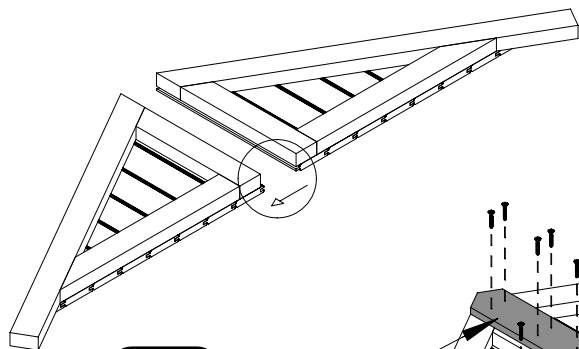
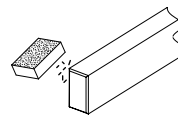
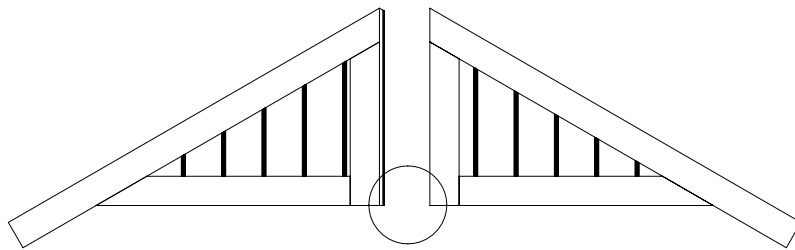

H-17 4,8x47,5x73,6cm
x2

!!! x2

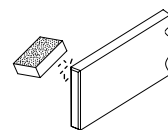

H-19 1,6x9,0x34,6cm
x1

H-15 1,6x9,0x102cm
x1

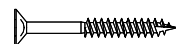

W40 x12*2 = 24

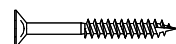
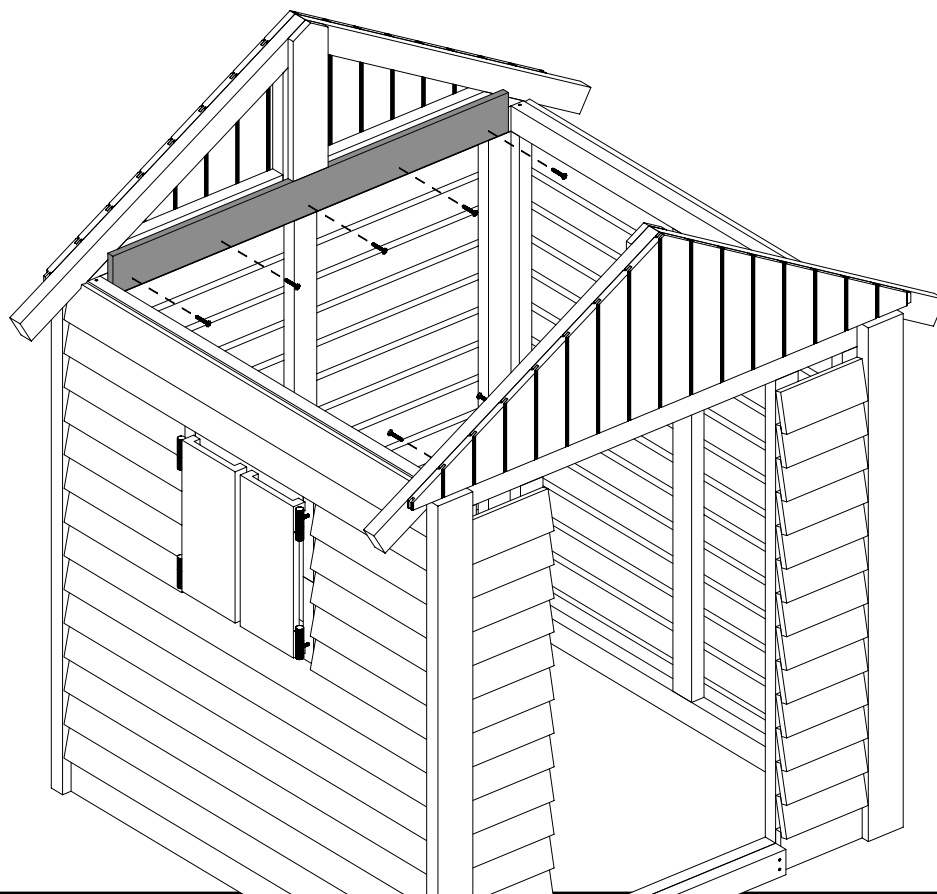

W40 x10

Zgodnie z normą PN-EN 71 stosuj zalecenia producenta odnośnie odległości oraz metody mocowania poszczególnych elementów
In compliance with the standard PN-EN 71, apply guidelines of the producer in relation to distances and methods of fastening individual elements

17

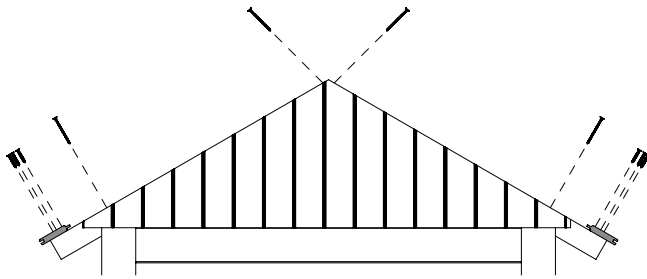

H-5 3,2x5,8x85cm x2

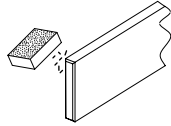

H-13 1,6x9,0x134cm x2

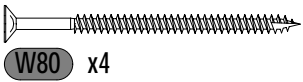
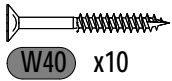
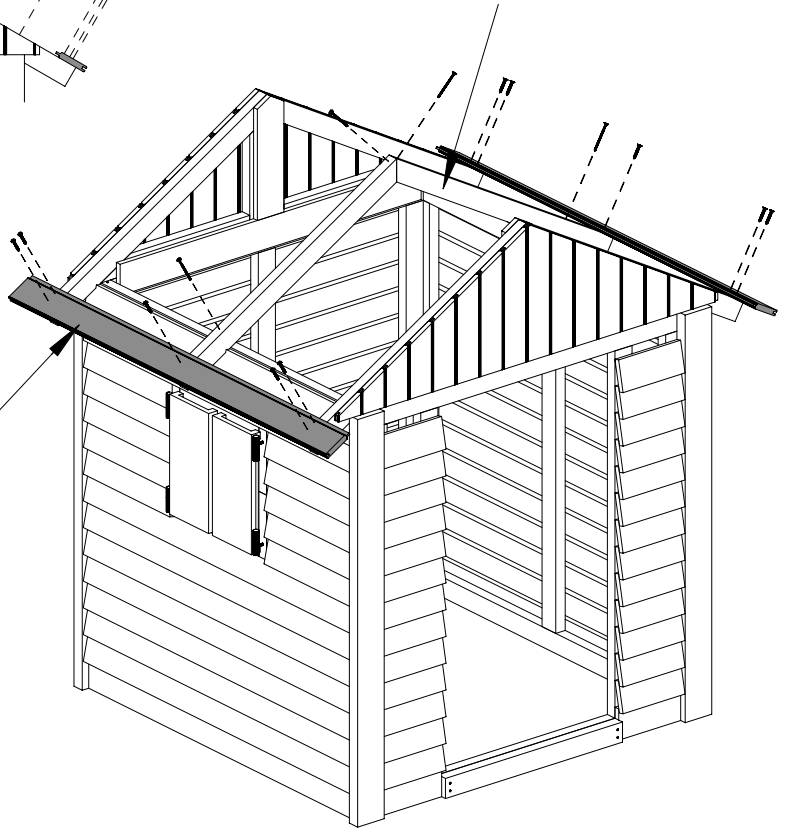

18

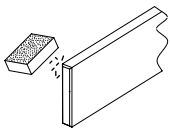
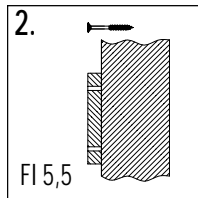
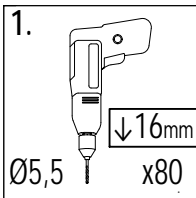

H-13 1,6x9,0x134cm x20

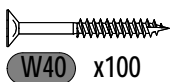
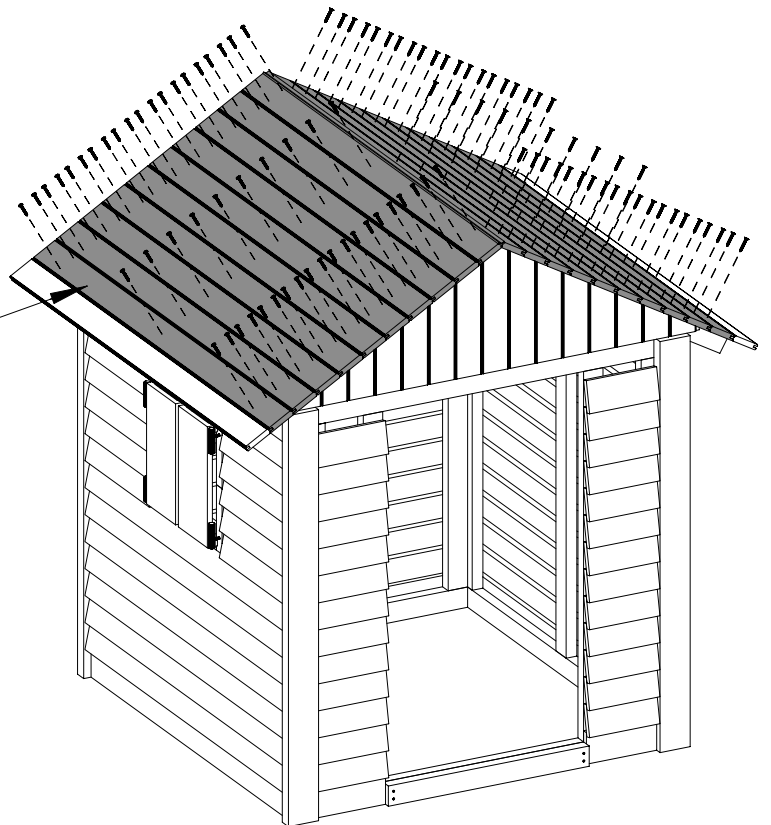

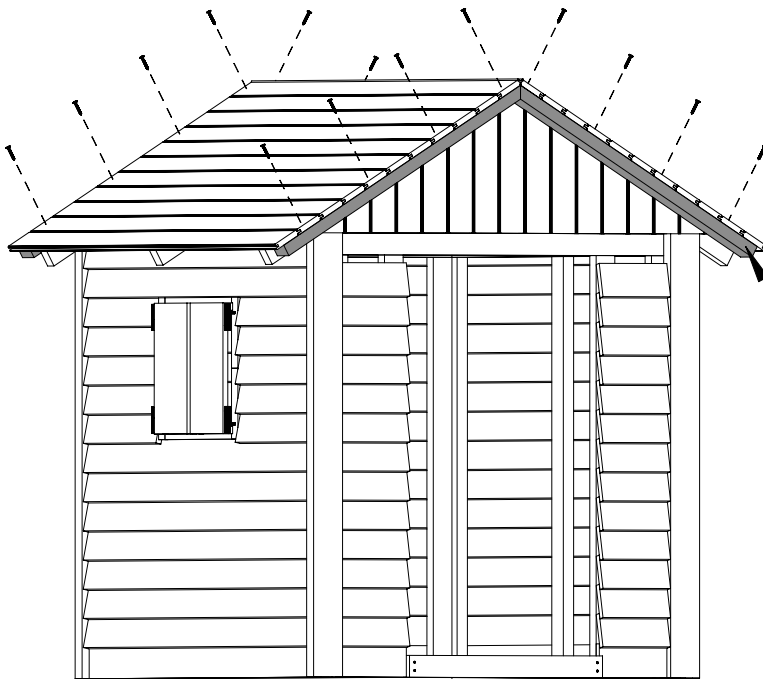
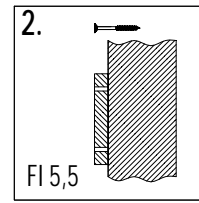
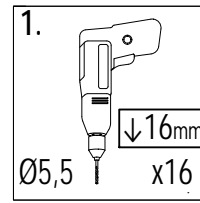
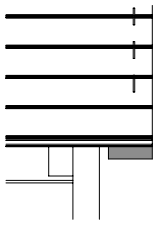

H-6 3,2x5,8x85cm
x4

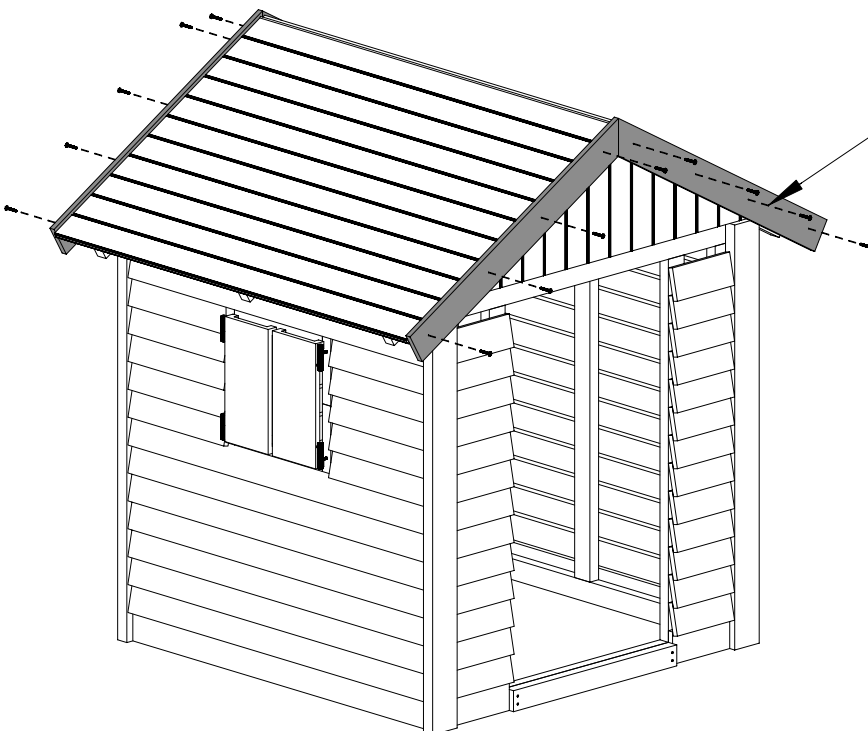
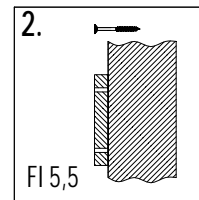
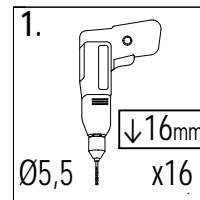
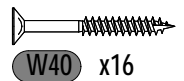
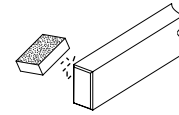

H-16 1,6x9,0x88,5cm
x4

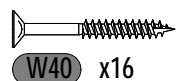
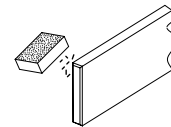

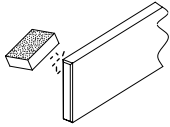
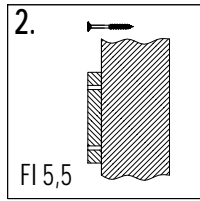
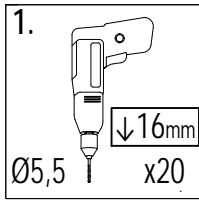

H-21 1,6x7,0x134cm
x2

H-22 1,6x3,5x134cm
x1

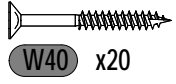
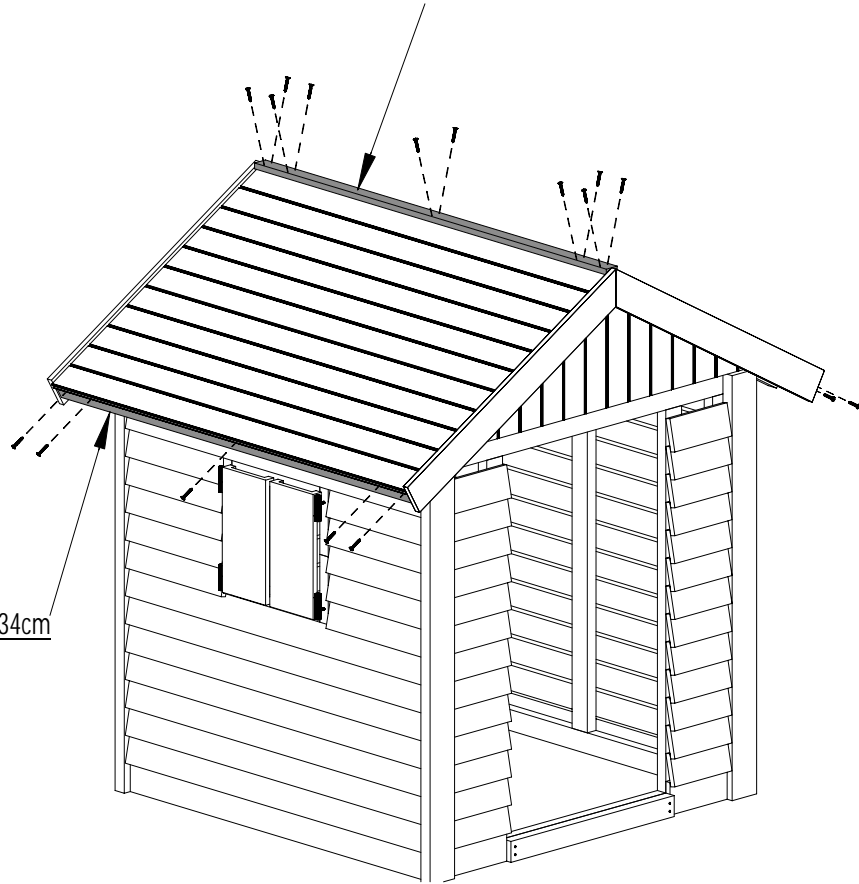

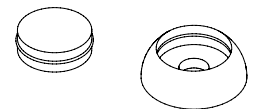
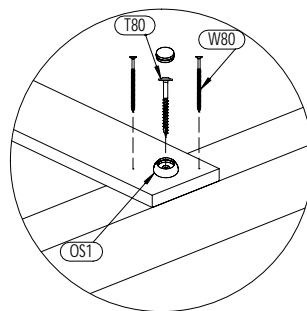
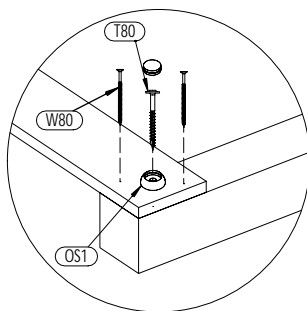
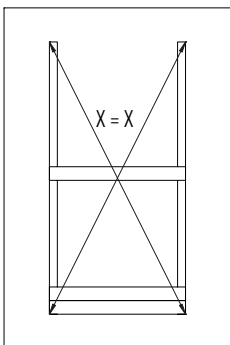
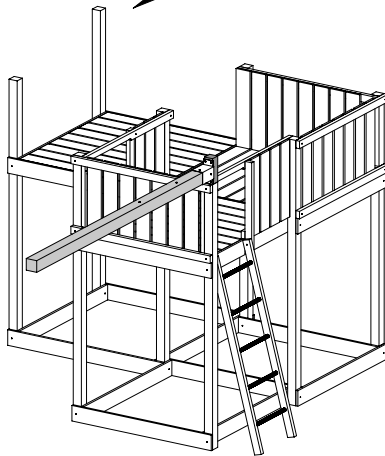
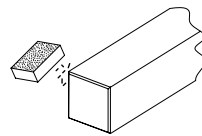
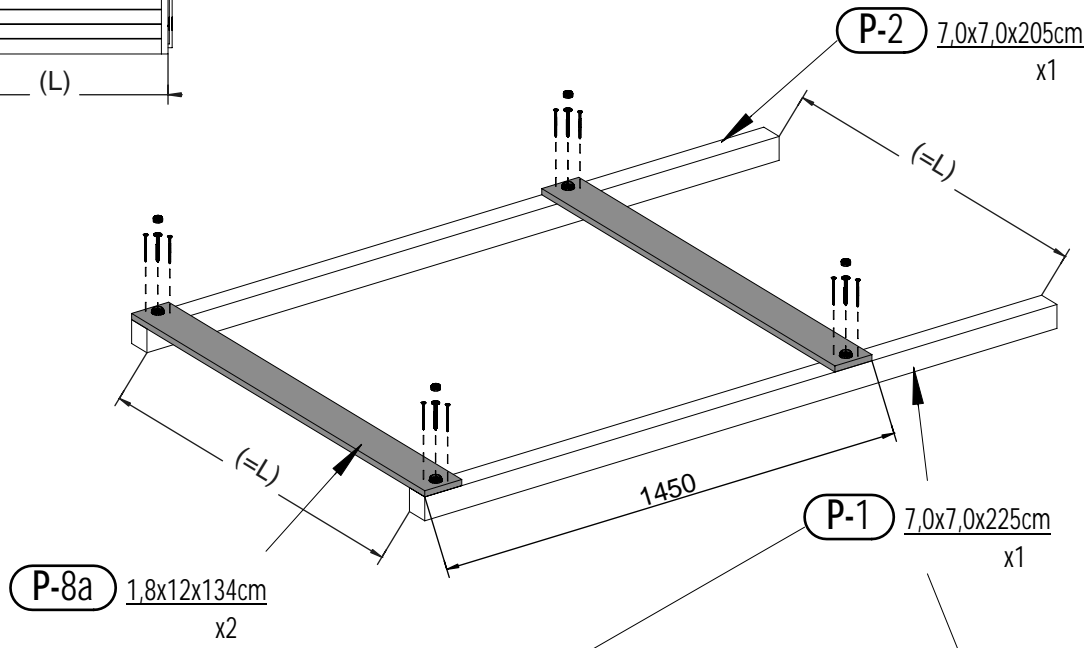
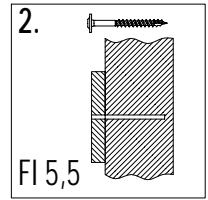
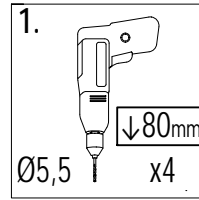
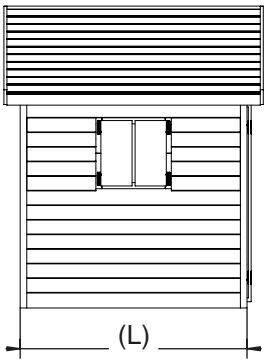

OS1 x4

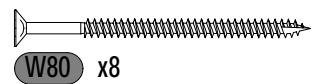

W80 x8

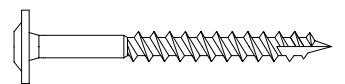

T80 x4

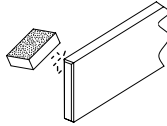
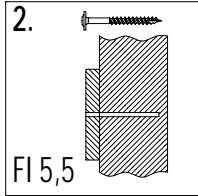
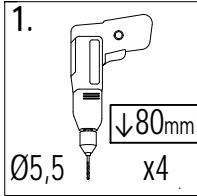

P-9a 1,8x12,0x120cm
x4

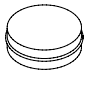
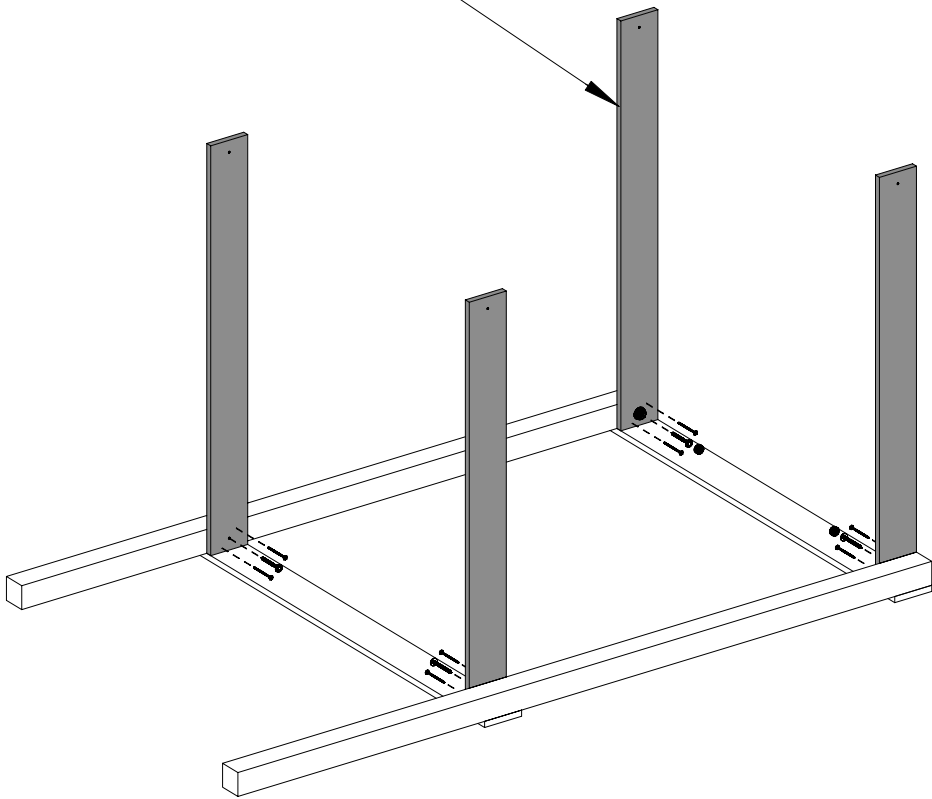

OS1 x2

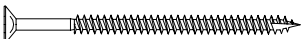

W80 x8

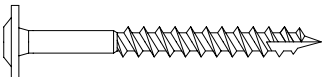

T80 x4

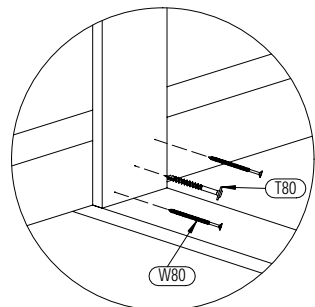
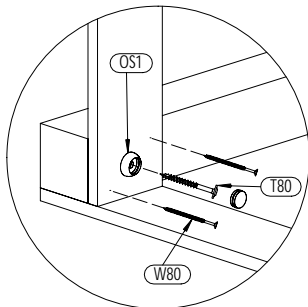

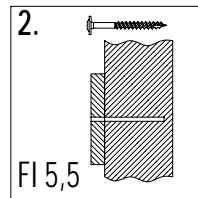
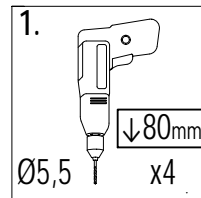
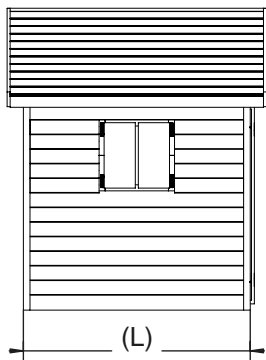

P-2 7,0x7,0x205cm x1

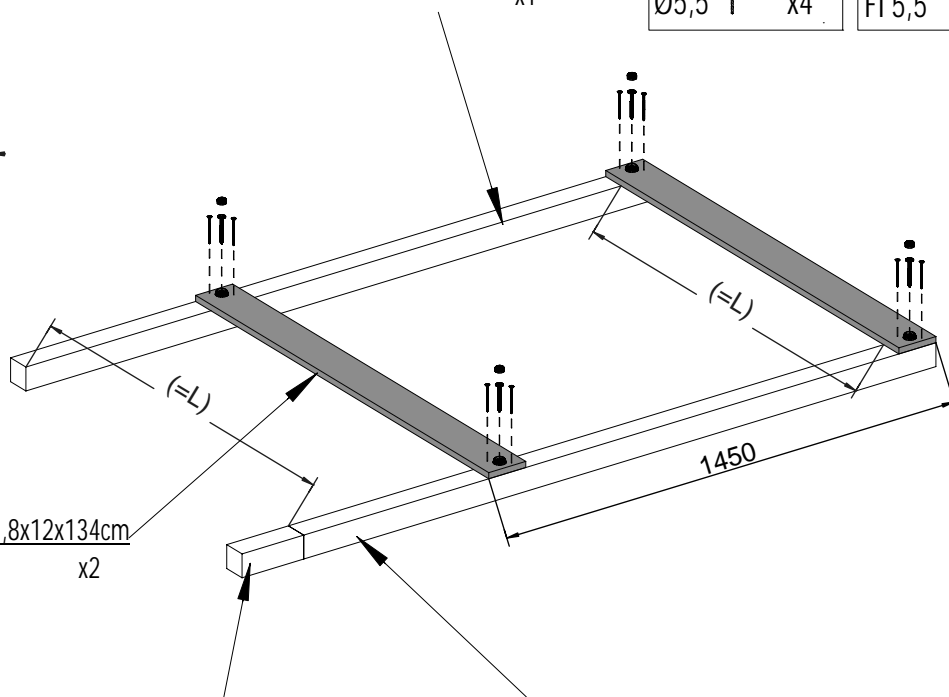

P-8a 1,8x12x134cm x2

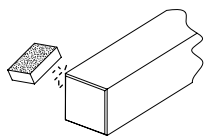

P-1 7,0x7,0x225cm x1

P-2 7,0x7,0x205cm x1

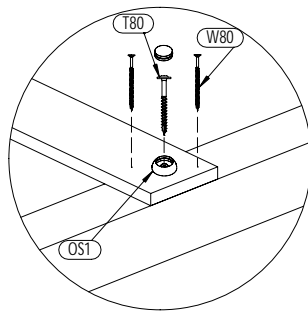
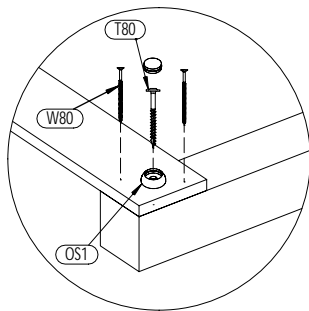
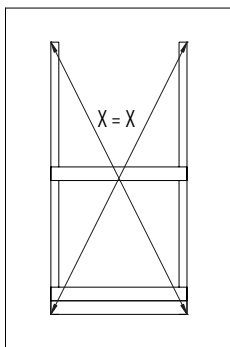
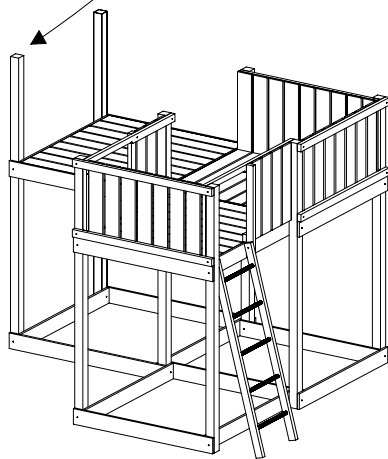

OS1 x4

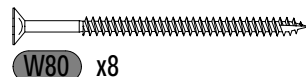

W80 x8

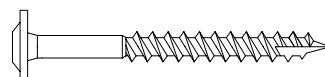

T80 x4

25

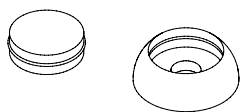
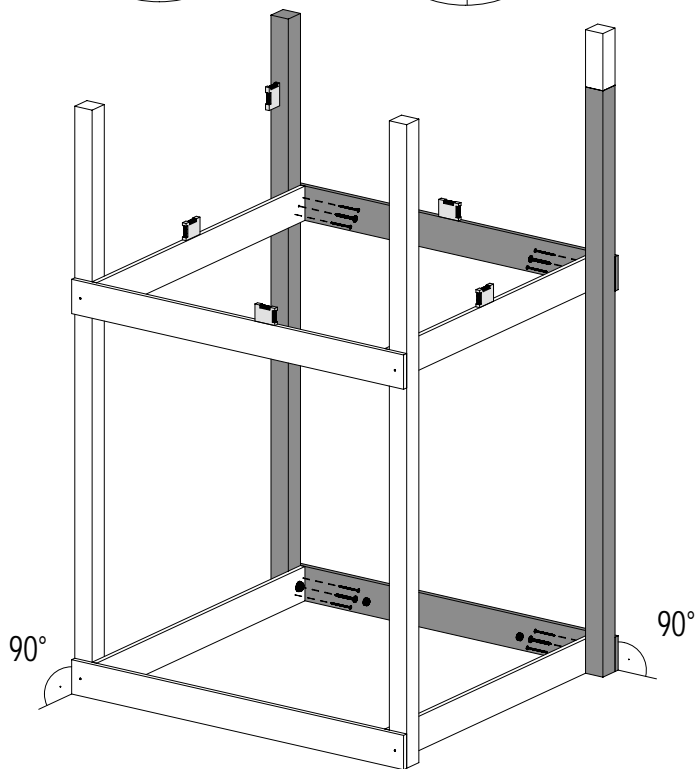
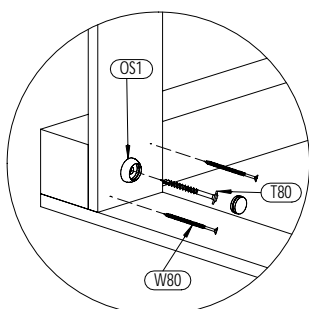
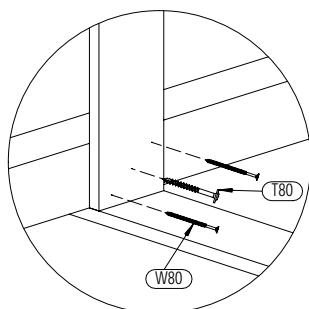
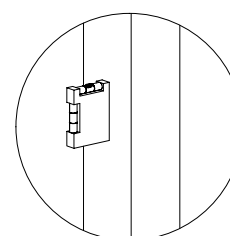
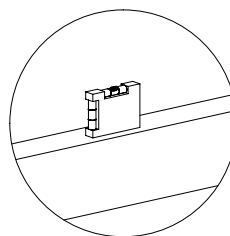
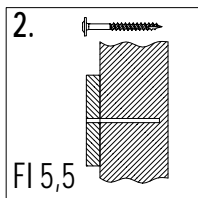
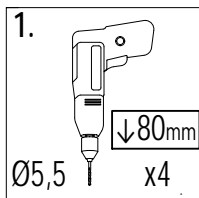

OS1 x2

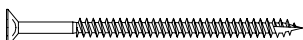

W80 x8

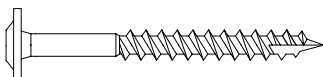

T80 x4

26

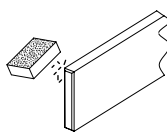
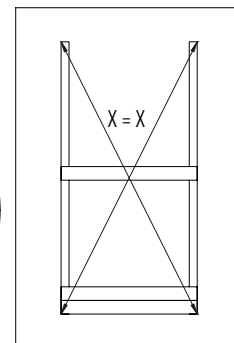
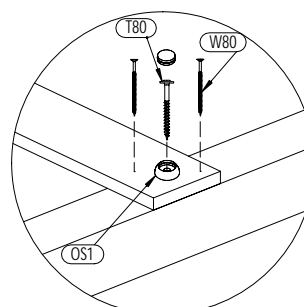
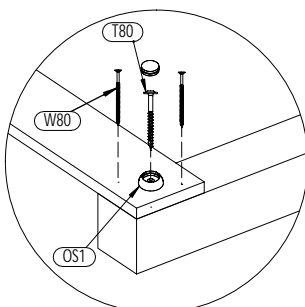
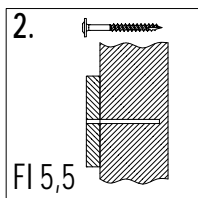
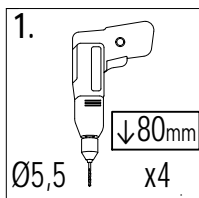

OS1 x4



W80 x8

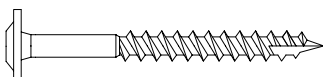

T80 x4

P-9a 1,8x12x120cm
x2

P-2 7,0x7,0x205cm
x2

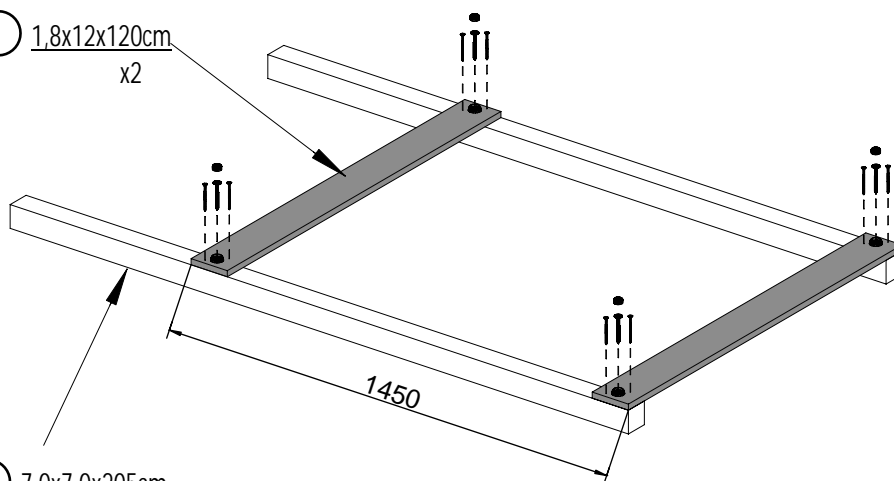

24

MY SIDE

Zgodnie z normą PN-EN 71 stosuj zalecenia producenta odnośnie odległości oraz metody mocowania poszczególnych elementów
In compliance with the standard PN-EN 71, apply guidelines of the producer in relation to distances and methods of fastening individual elements

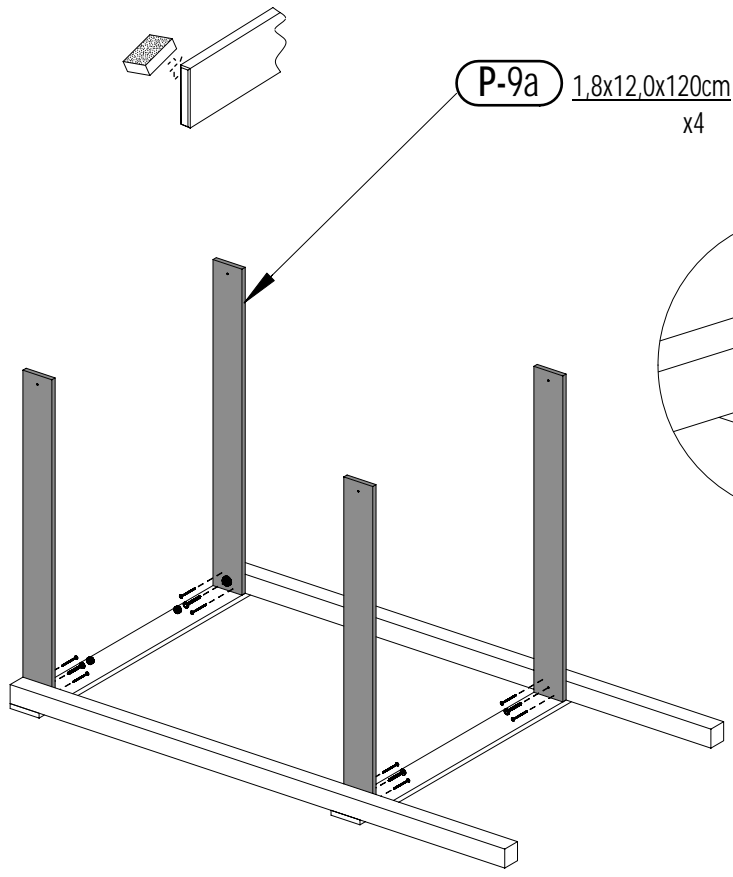

P-9a 1,8x12,0x120cm
x4

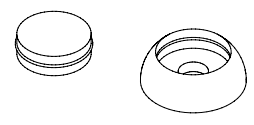
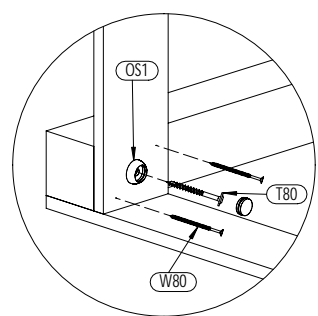
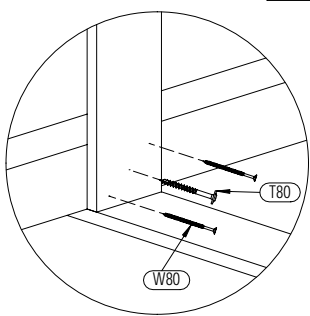
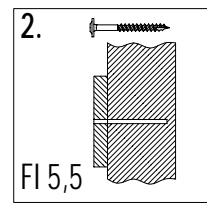
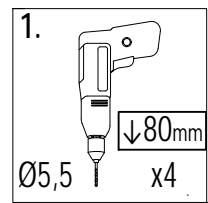

OS1 x2

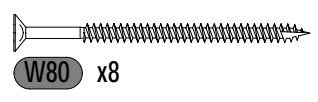

W80 x8

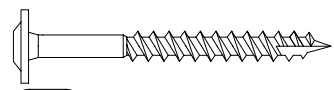

T80 x4

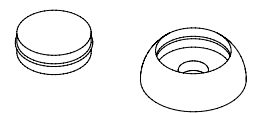
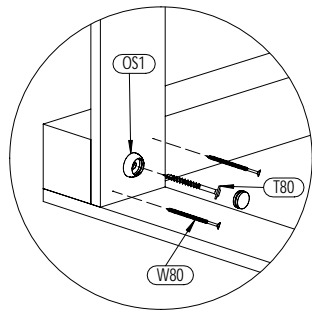
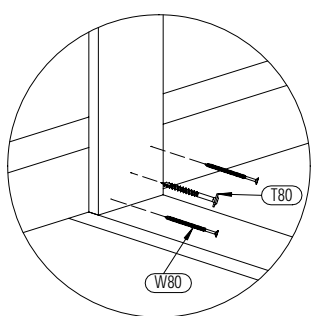
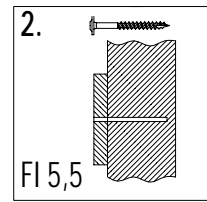
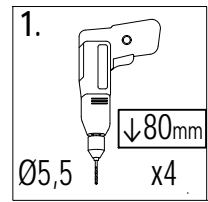
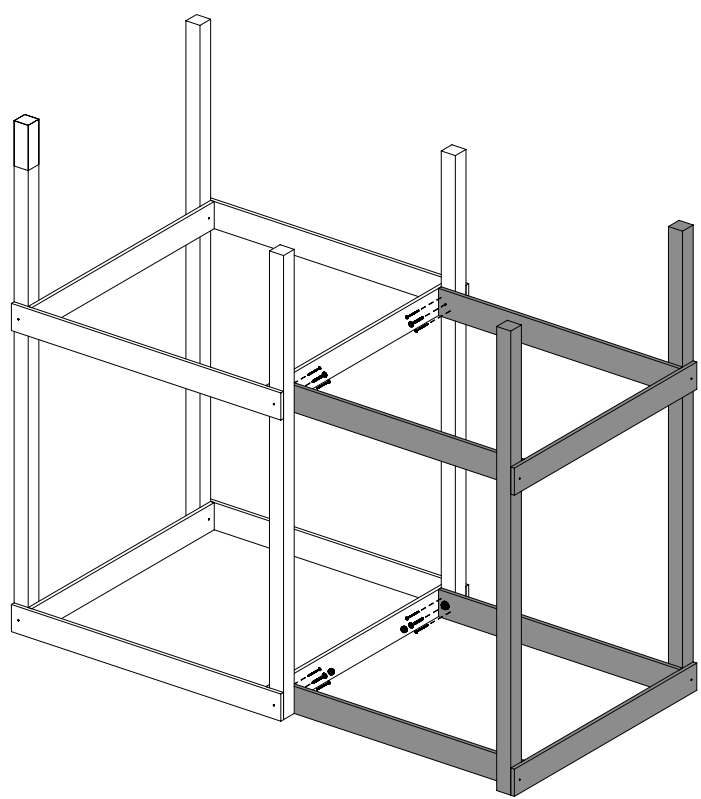

OS1 x2

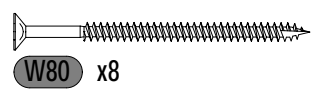

W80 x8

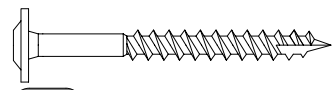

T80 x4

Zgodnie z normą PN-EN 71 stosuj zalecenia producenta odnośnie odległości oraz metody mocowania poszczególnych elementów
In compliance with the standard PN-EN 71, apply guidelines of the producer in relation to distances and methods of fastening individual elements

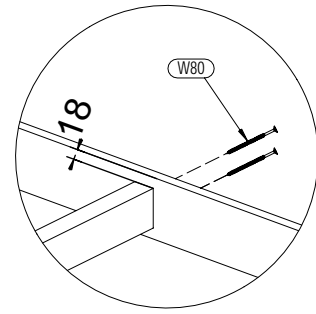
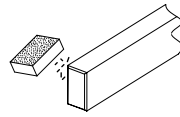

P-4 3,2x5,8x120cm
x2

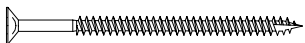
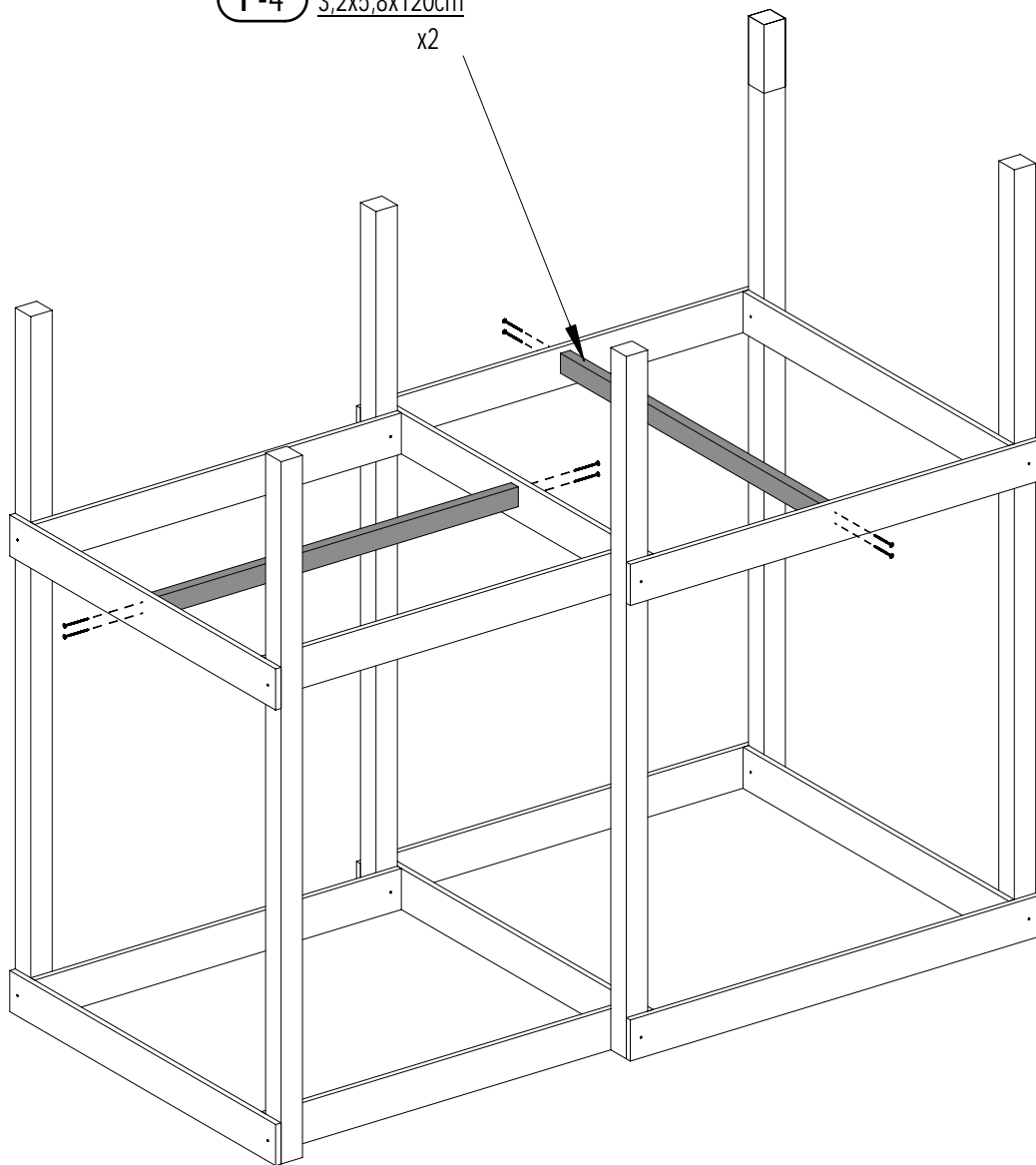

W80 x8

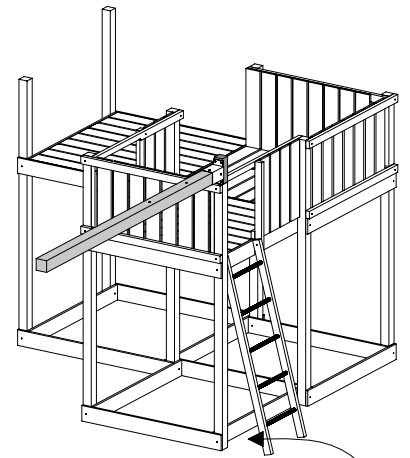
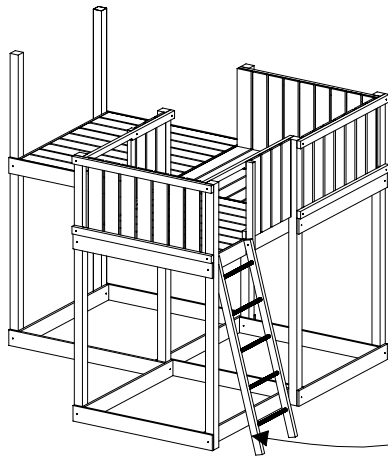
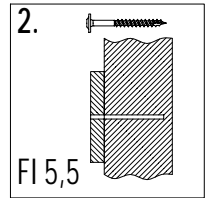
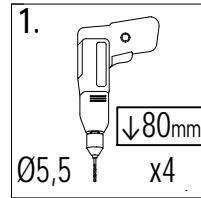

P-2 $7,0 \times 7,0 \times 205\text{cm}$
x1

P-2 $7,0 \times 7,0 \times 205\text{cm}$
x1

P-1 $7,0 \times 7,0 \times 225\text{cm}$
x1

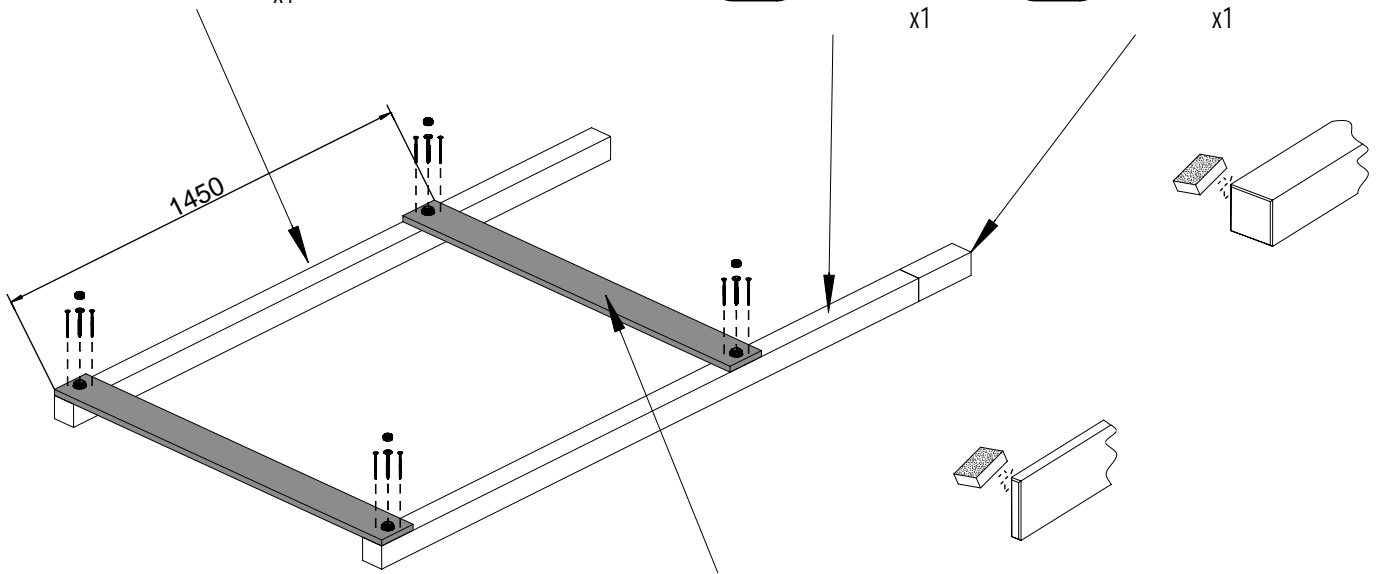

P-9a $1,8 \times 12 \times 120\text{cm}$
x2

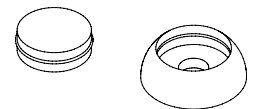
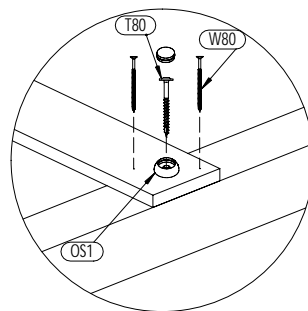
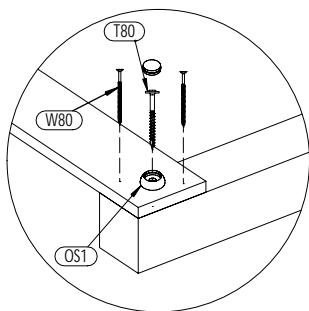
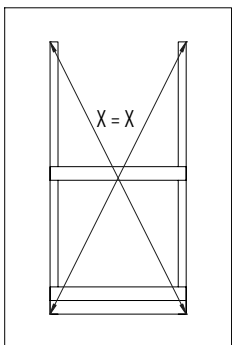

OS1 x4



W80 x8

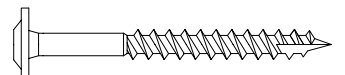

T80 x4

31

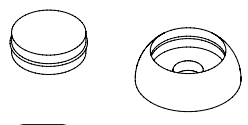
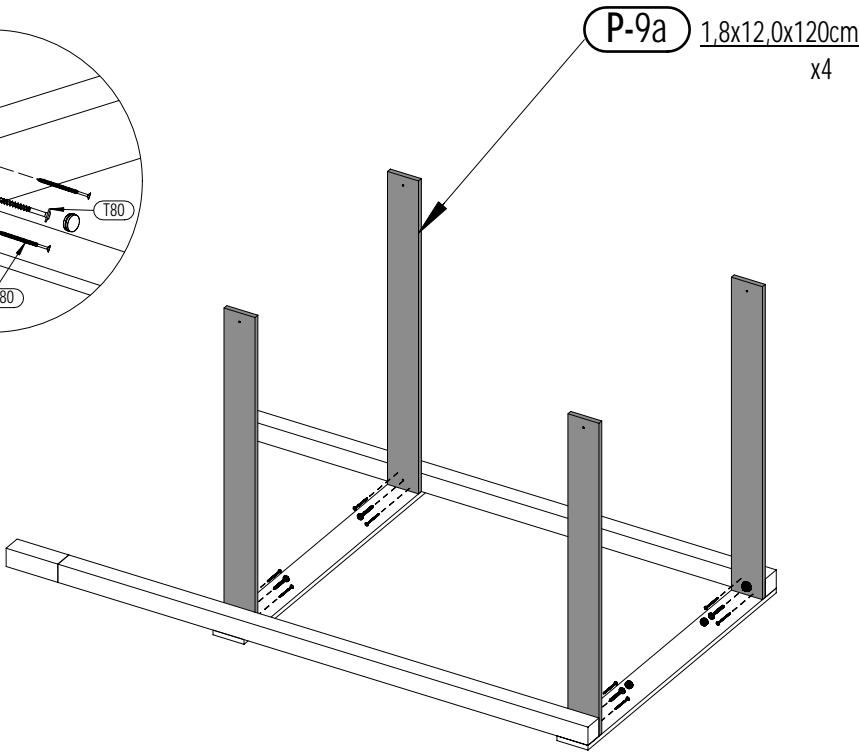
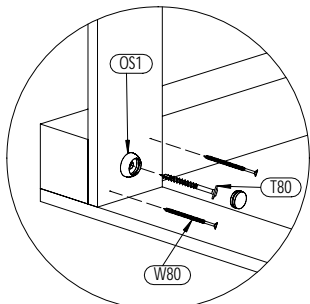
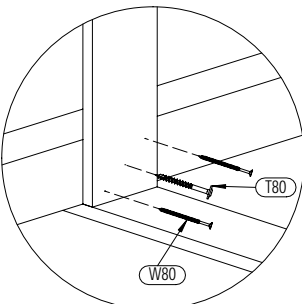
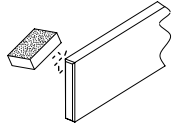
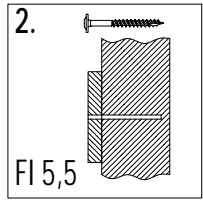
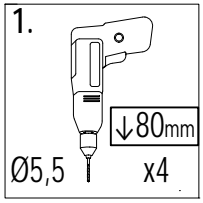

OS1 x2



W80 x8

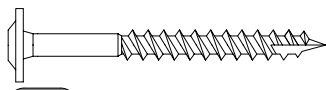

T80 x4

32

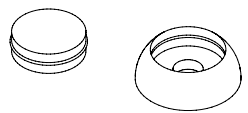
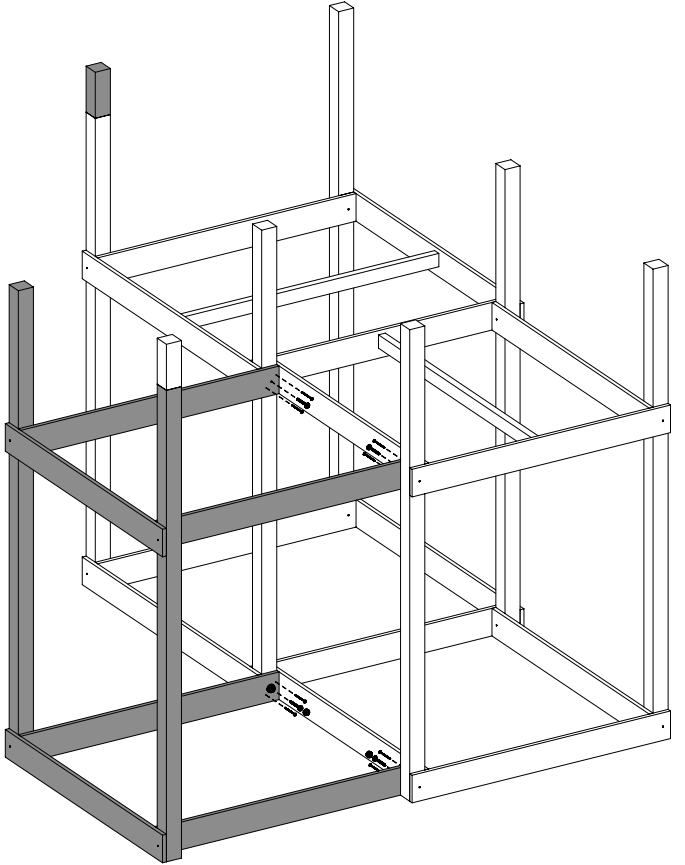
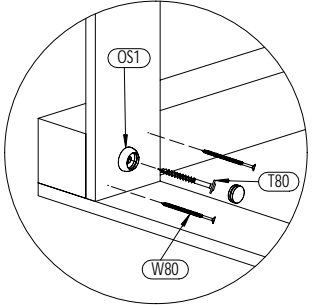
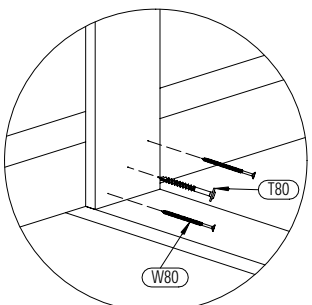
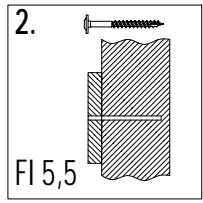
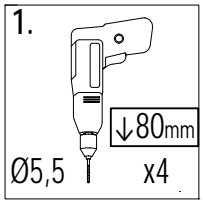

OS1 x2

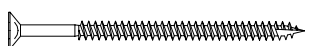

W80 x8

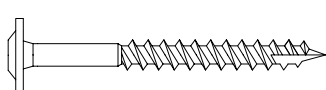

T80 x4

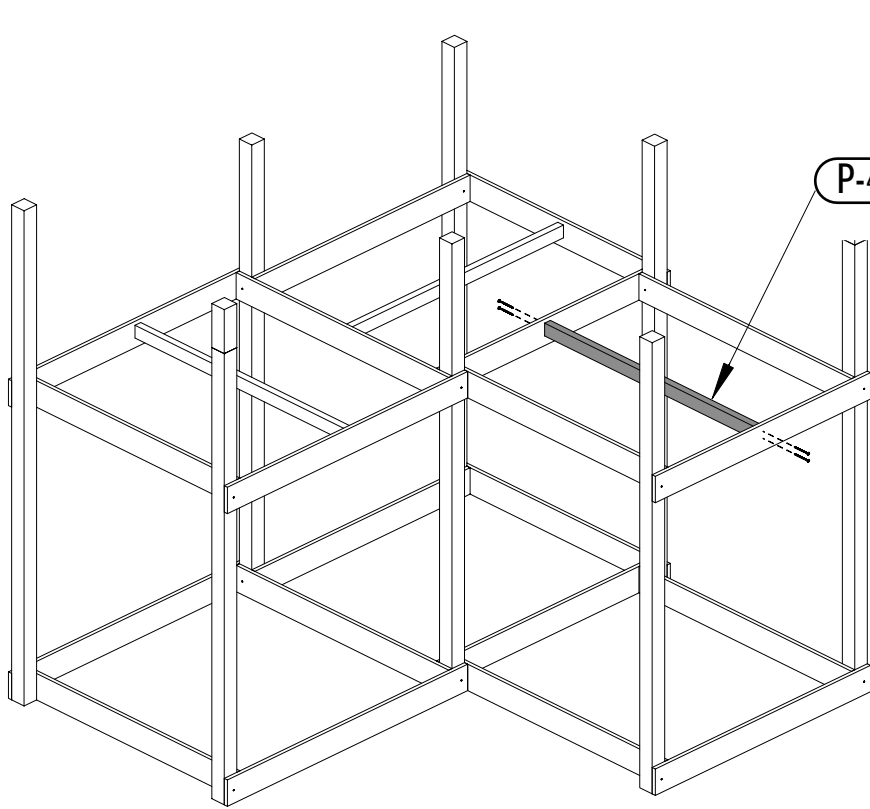

P-4 3,2x5,8x120cm
x1

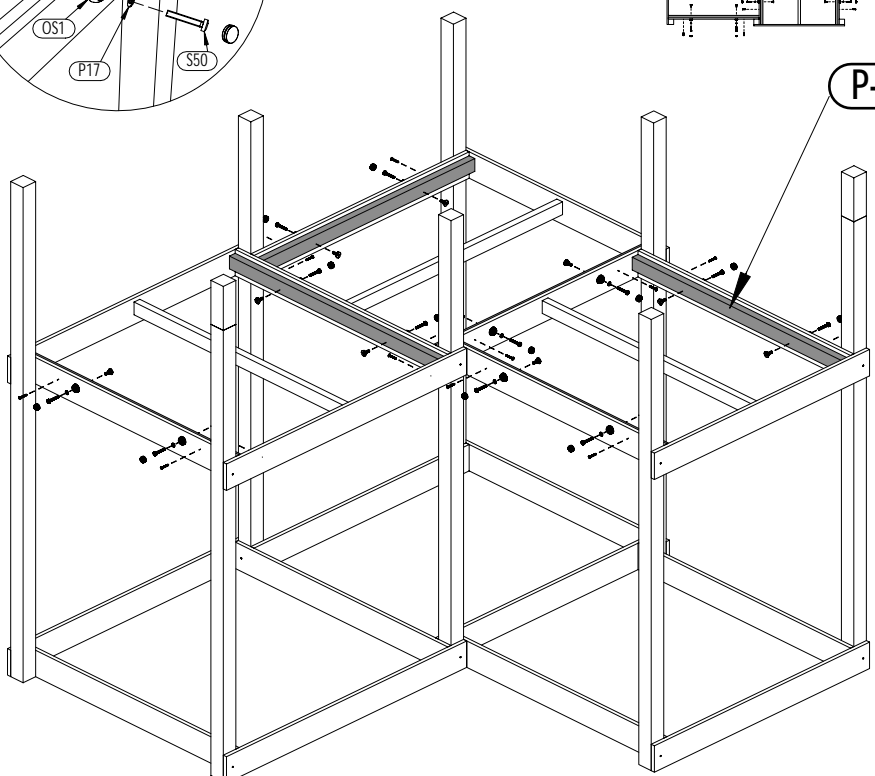
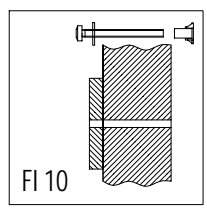
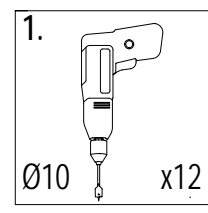
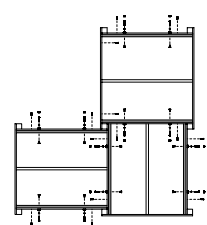
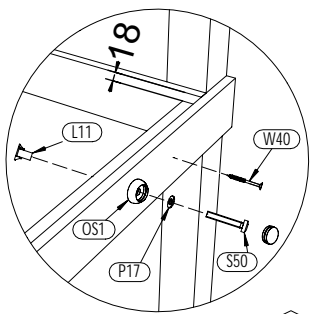
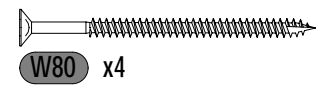
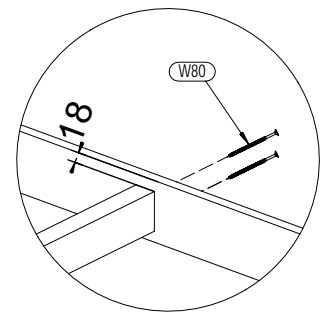
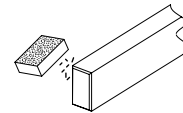

P-4 3,2x5,8x120cm
x6

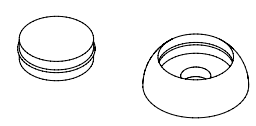
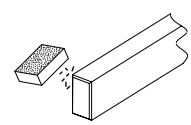

OS1 x12

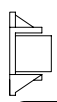
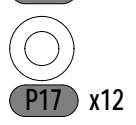
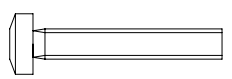
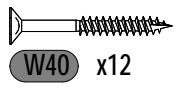

L11 x12

Zgodne z normą PN-EN 71 stosuj zalecenia producenta odnośnie odległości oraz metody mocowania poszczególnych elementów
In compliance with the standard PN-EN 71, apply guidelines of the producer in relation to distances and methods of fastening individual elements

35

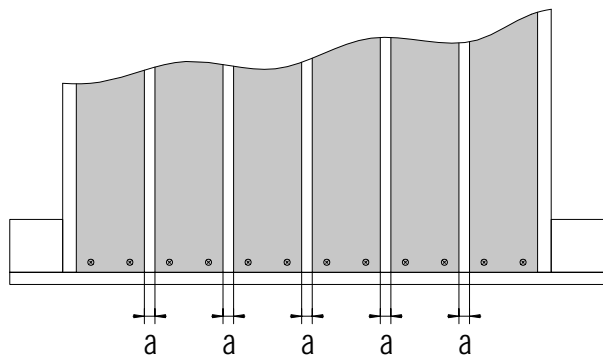
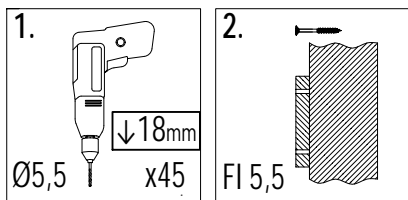

!!!min 13mm < **a** <!!!max 15mm

P-10 1,8x12x116,4cm x9

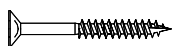
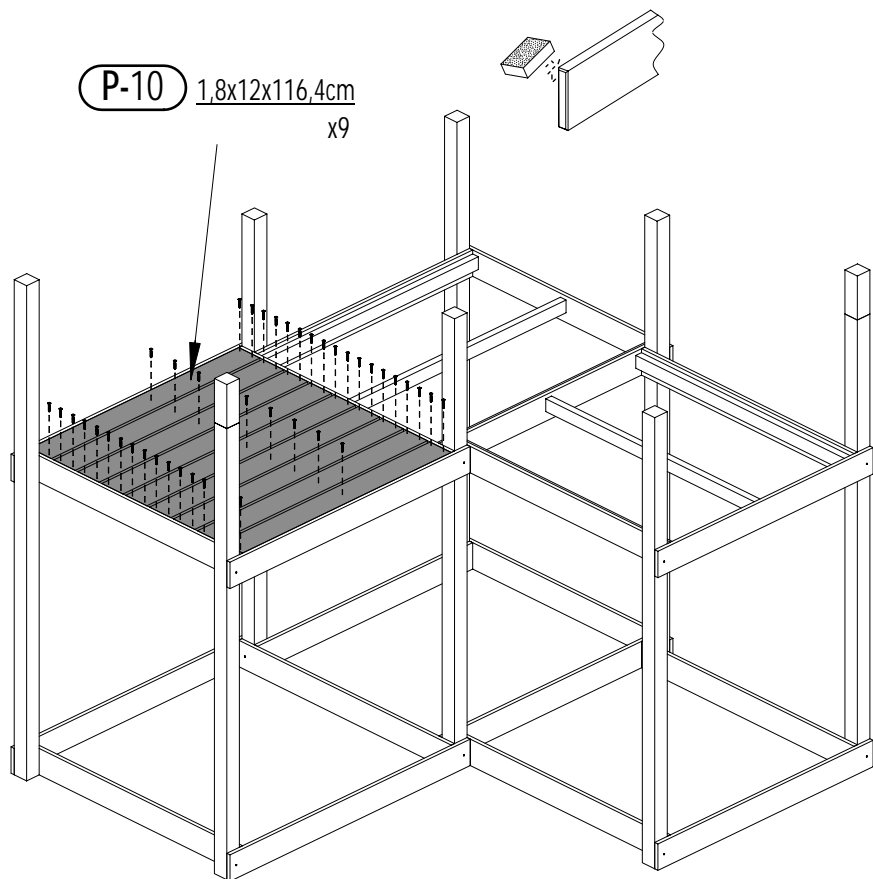

W40 x45

36

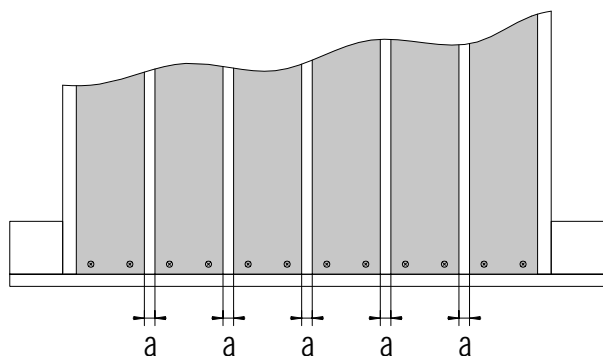
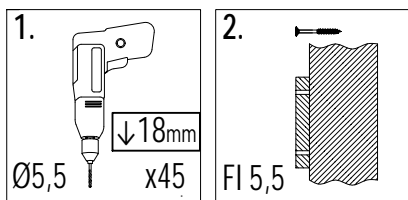

!!!min 13mm < **a** <!!!max 15mm

P-11 1,8x12x102,4cm x9

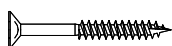
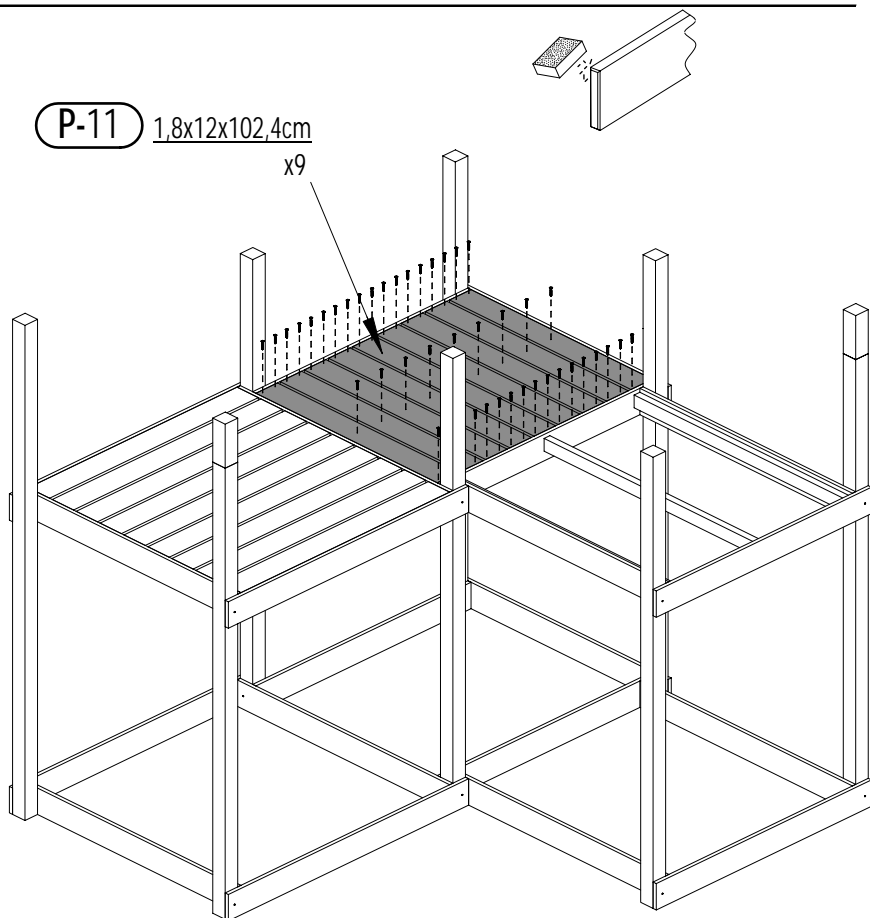

W40 x45

30 MY SIDE

Zgodnie z normą PN-EN 71 stosuj zalecenia producenta odnośnie odległości oraz metody mocowania poszczególnych elementów
In compliance with the standard PN-EN 71, apply guidelines of the producer in relation to distances and methods of fastening individual elements

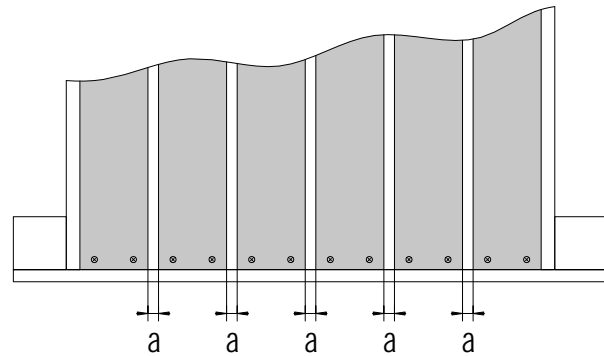
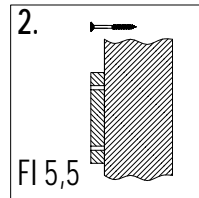
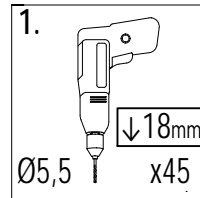
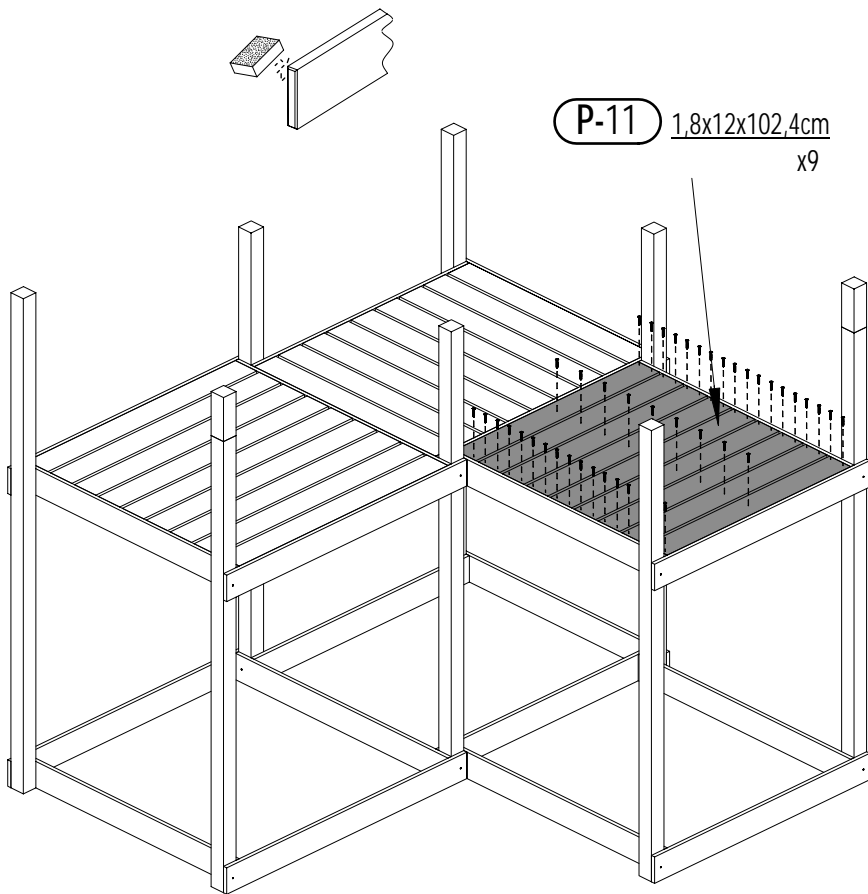

!!!min 13mm < a <!!!max 15mm

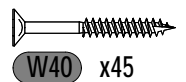

P-4a 3,2x5,8x120cm x2

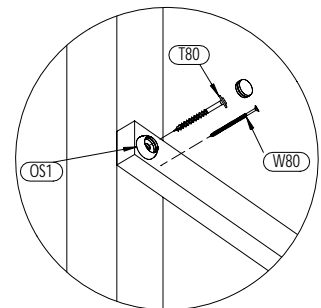
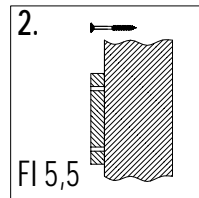
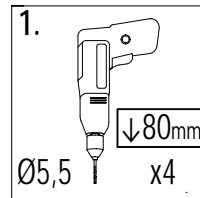
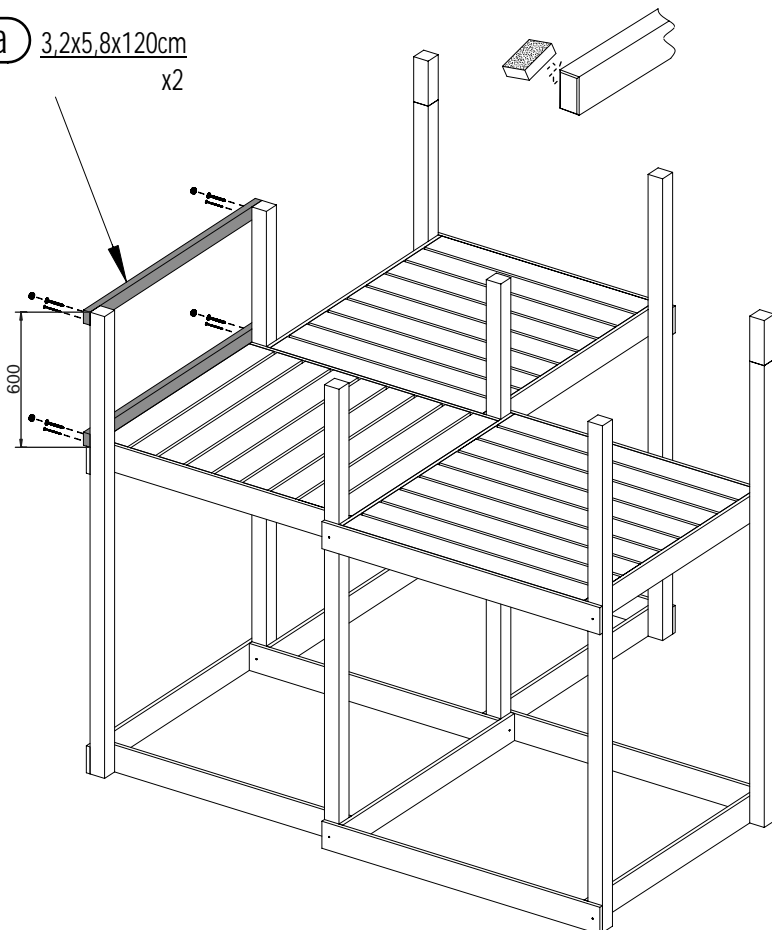

OS1 x4

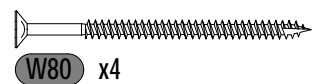

W80 x4

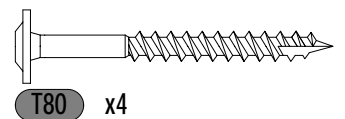

T80 x4

39

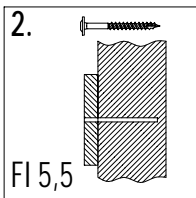
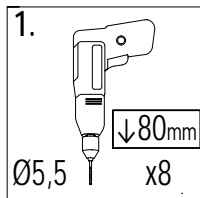

P-4b $3,2 \times 5,8 \times 120\text{cm}$
 x2

P-4a $3,2 \times 5,8 \times 120\text{cm}$
 x2

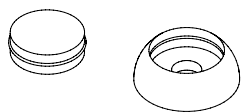
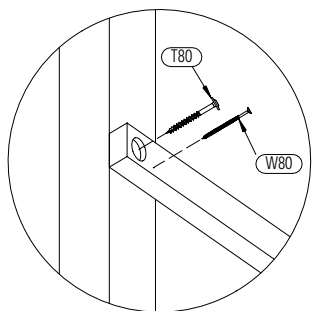

OS1 x4

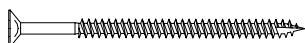

W80 x8

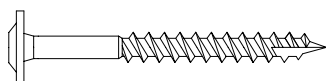

T80 x8

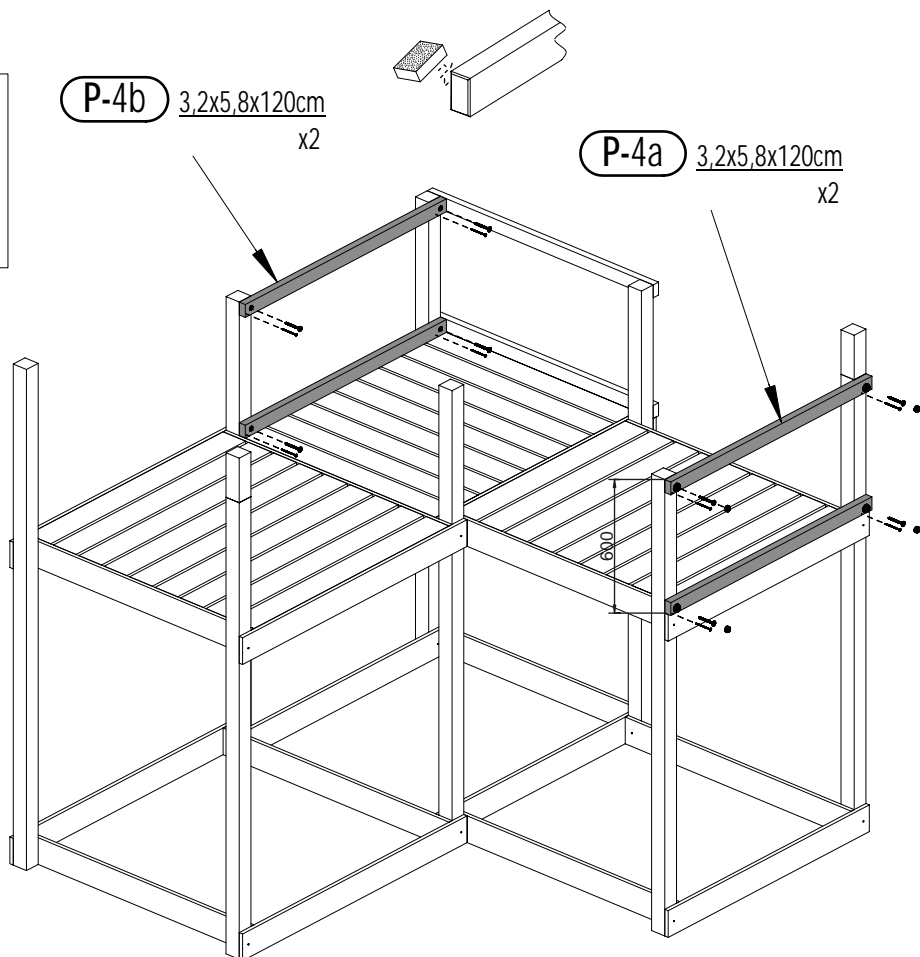

40

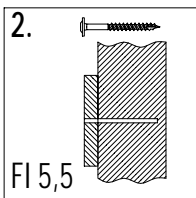
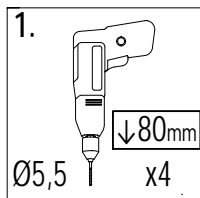

P-4c $3,2 \times 5,8 \times 120\text{cm}$
 x1

P-4d $3,2 \times 5,8 \times 120\text{cm}$
 x1

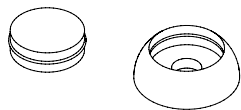
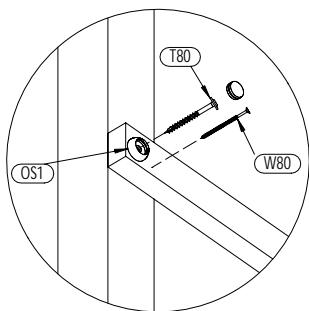

OS1 x4

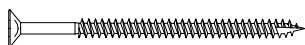

W80 x4

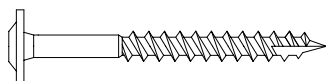

T80 x4

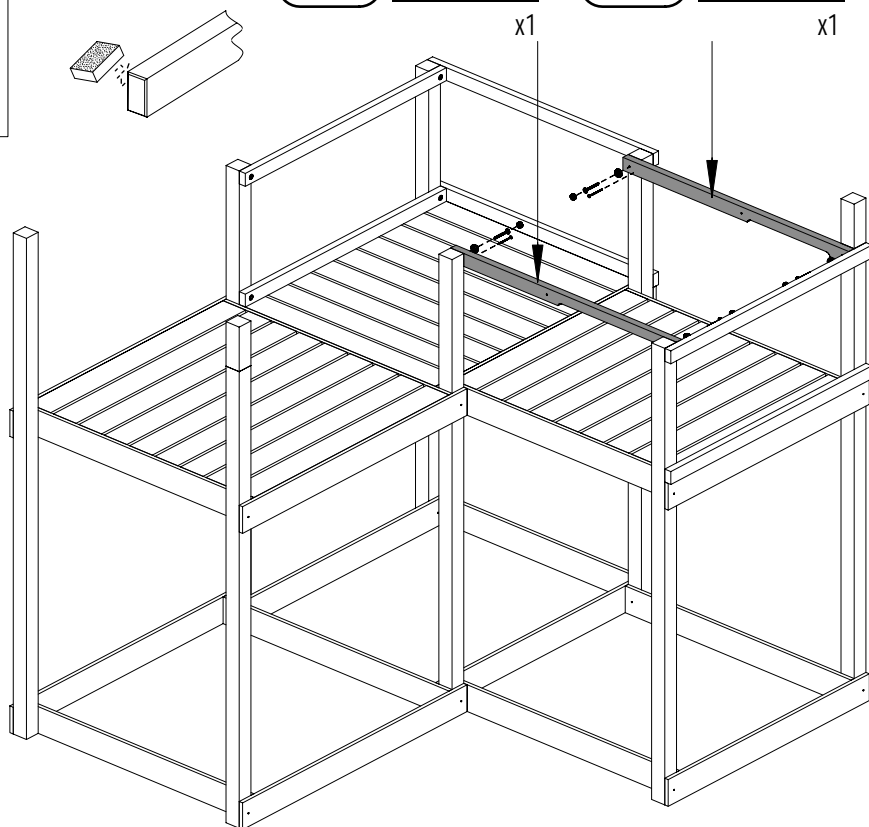

32

MY SIDE

Zgodnie z normą PN-EN 71 stosuj zalecenia producenta odnośnie odległości oraz metody mocowania poszczególnych elementów
 In compliance with the standard PN-EN 71, apply guidelines of the producer in relation to distances and methods of fastening individual elements

P-6a 3,2x5,8x65cm

x1

P-7a 3,2x5,8x54cm

x1

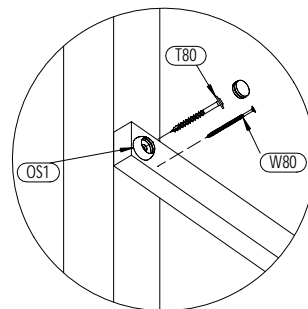
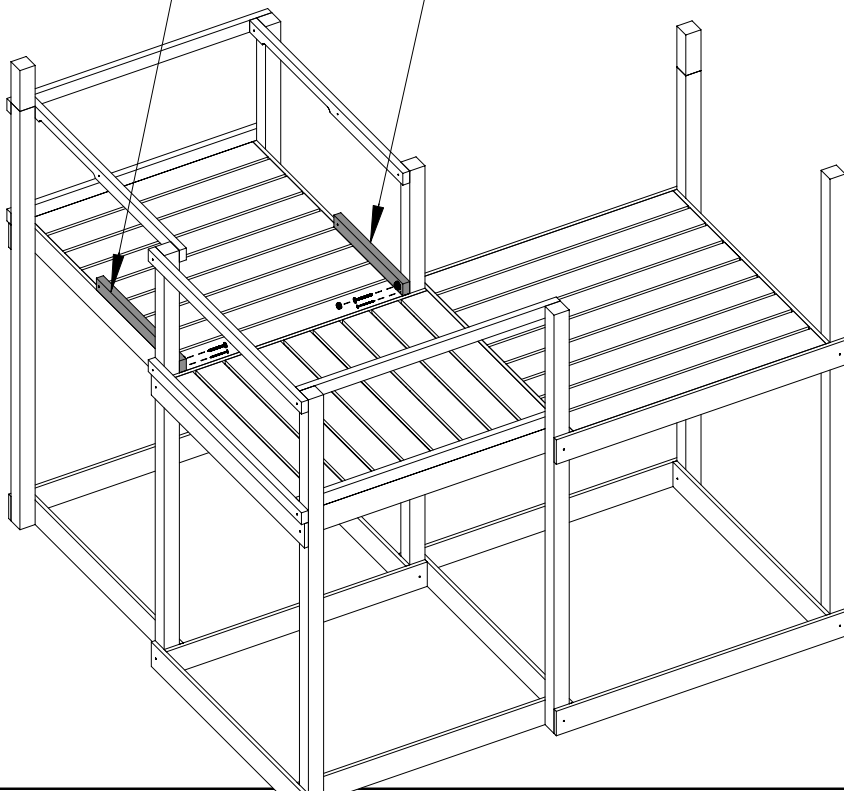
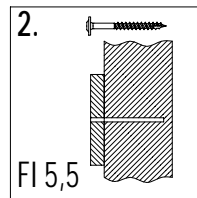
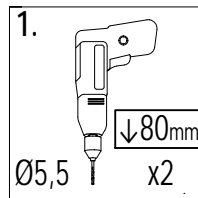
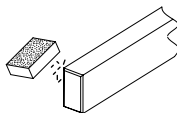

OS1 x2

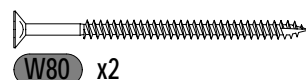

W80 x2

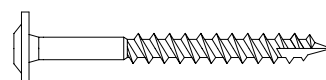

T80 x2

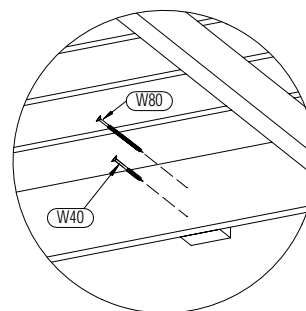
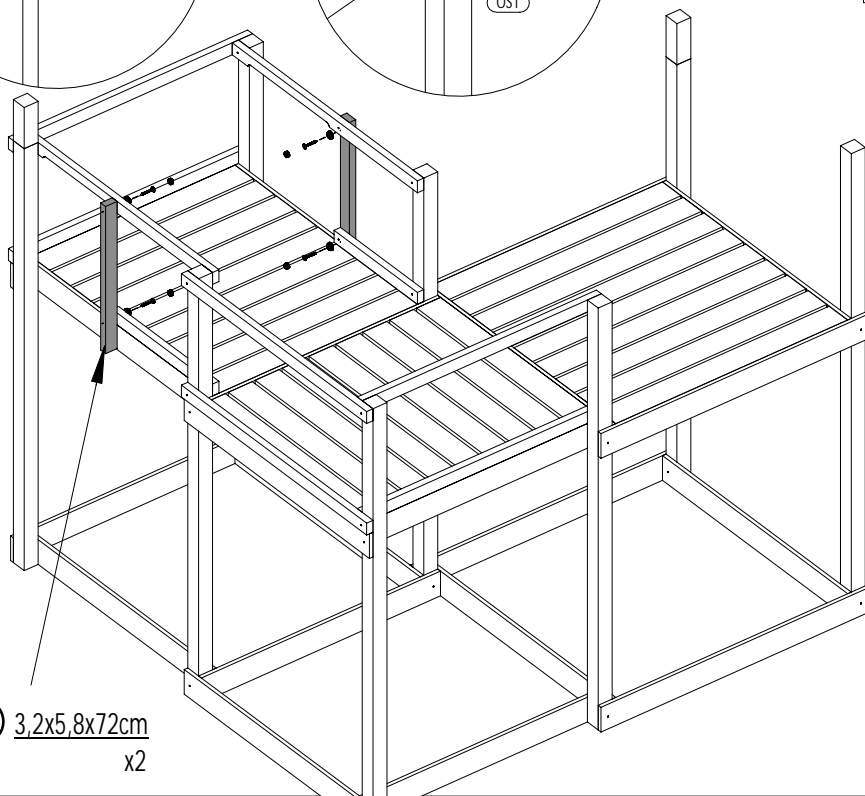
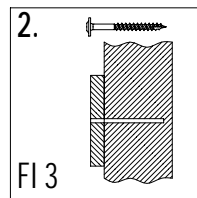
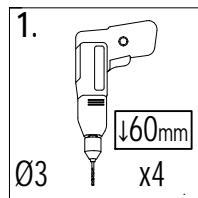
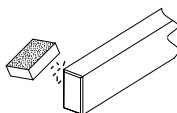
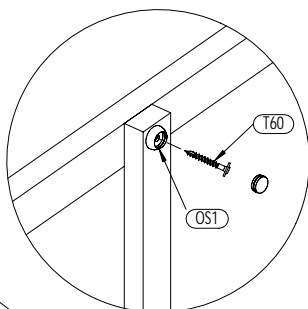
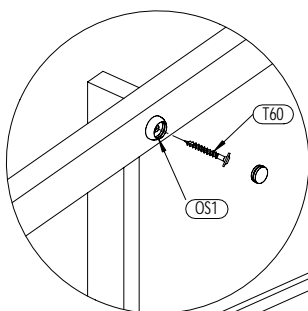

OS1 x4



W40 x2

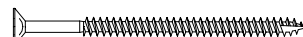

W80 x2

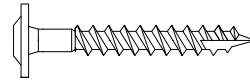

T60 x4

P-5 3,2x5,8x72cm

x2

Zgodne z normą PN-EN 71 stosuj zalecenia producenta odnośnie odległości oraz metody mocowania poszczególnych elementów

In compliance with the standard PN-EN 71, apply guidelines of the producer in relation to distances and methods of fastening individual elements

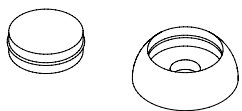
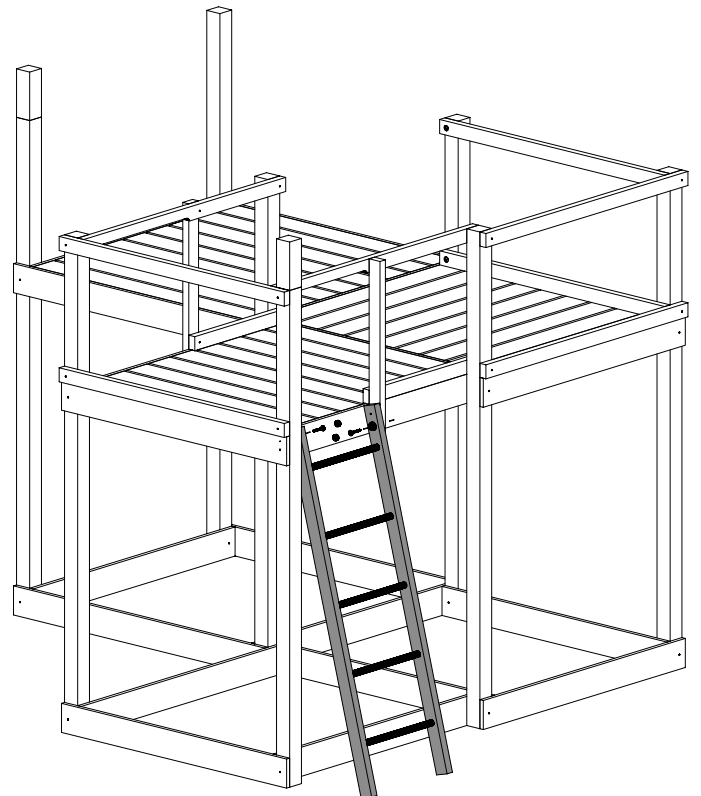
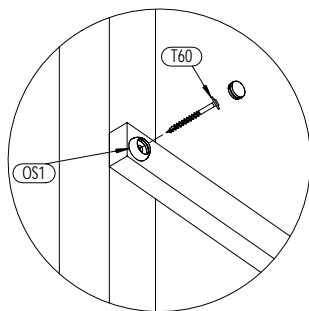
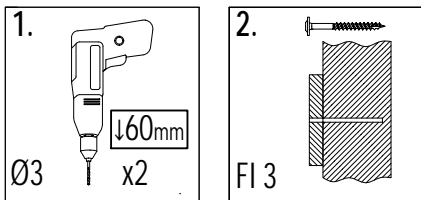
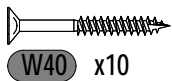
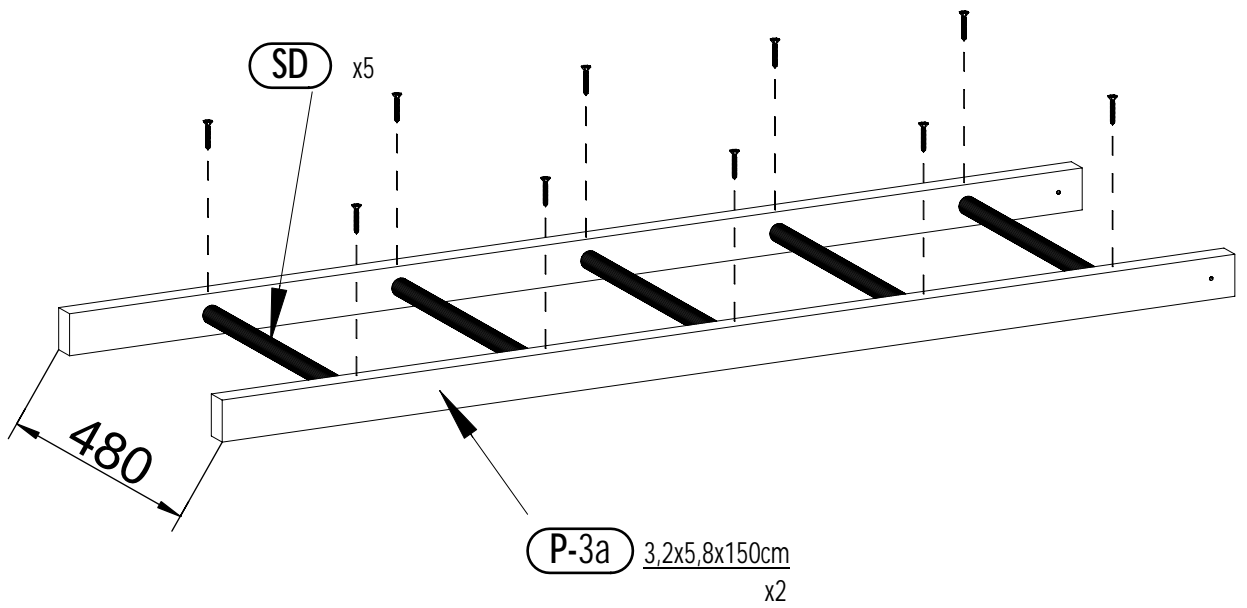
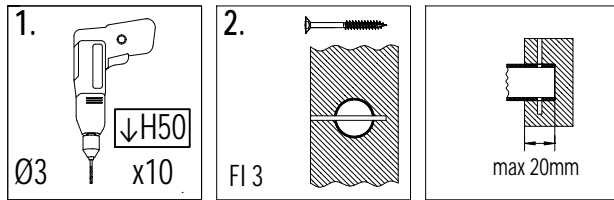

OS1 x2

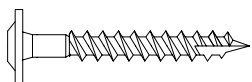

T60 x2

P-13a 2,7x3,2x54,2cm
x2

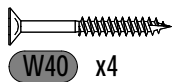
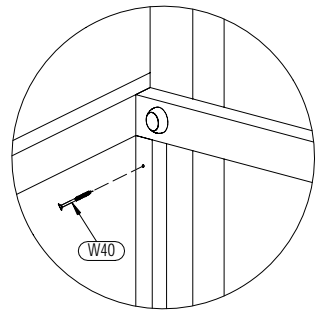
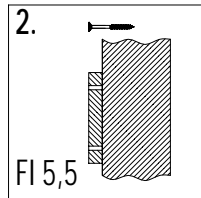
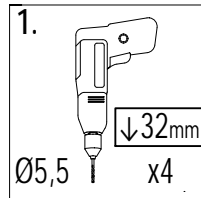
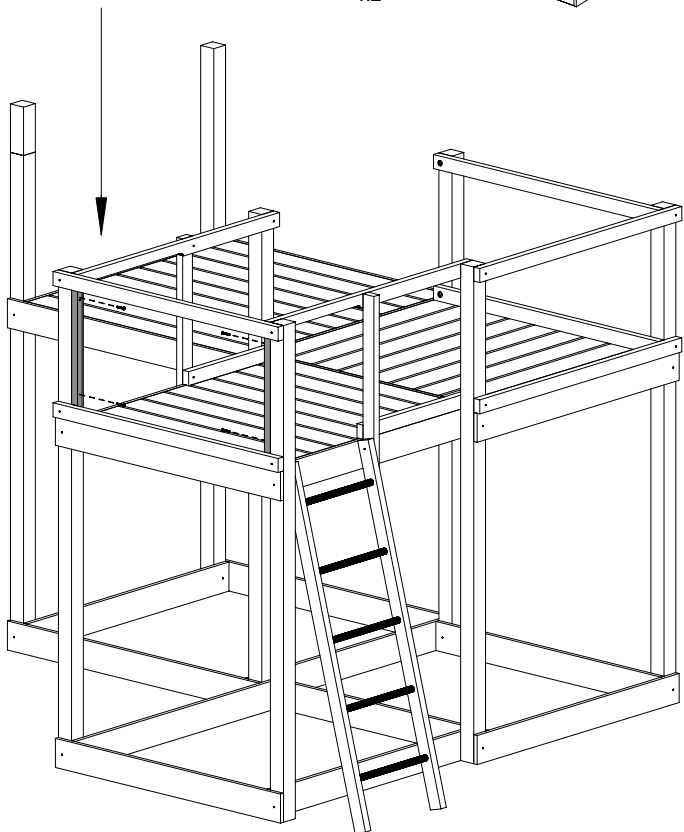
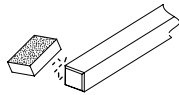

P-12 1,8x12x60cm
x9

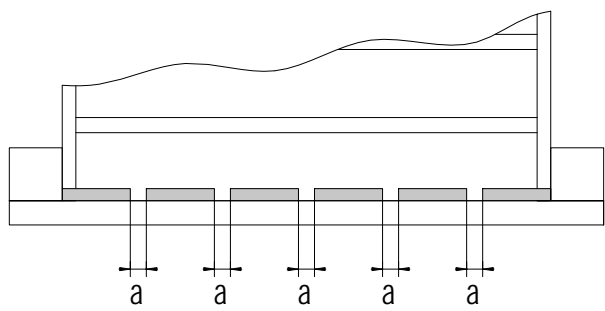
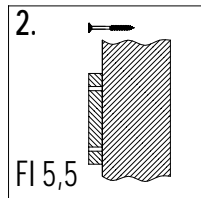
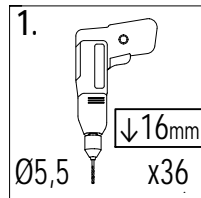
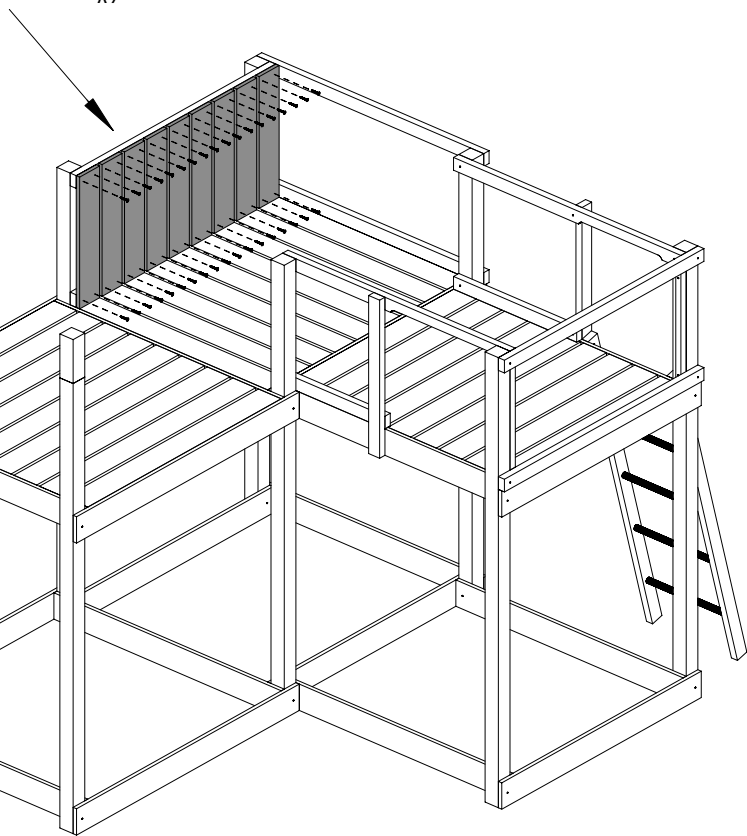

!!!min 13mm < a <!!!max 15mm

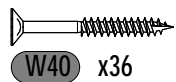

Zgodnie z normą PN-EN 71 stosuj zalecenia producenta odnośnie odległości oraz metody mocowania poszczególnych elementów
In compliance with the standard PN-EN 71, apply guidelines of the producer in relation to distances and methods of fastening individual elements

47

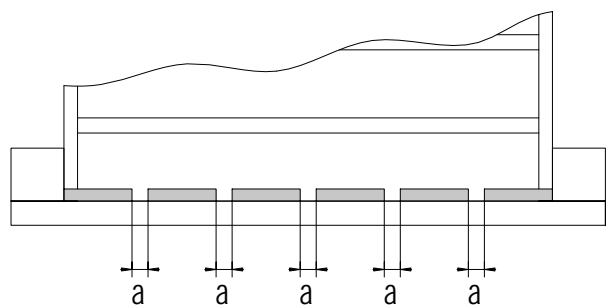
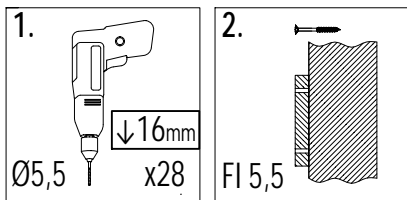

!!!min 13mm < **a** <!!!max 23mm

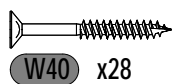
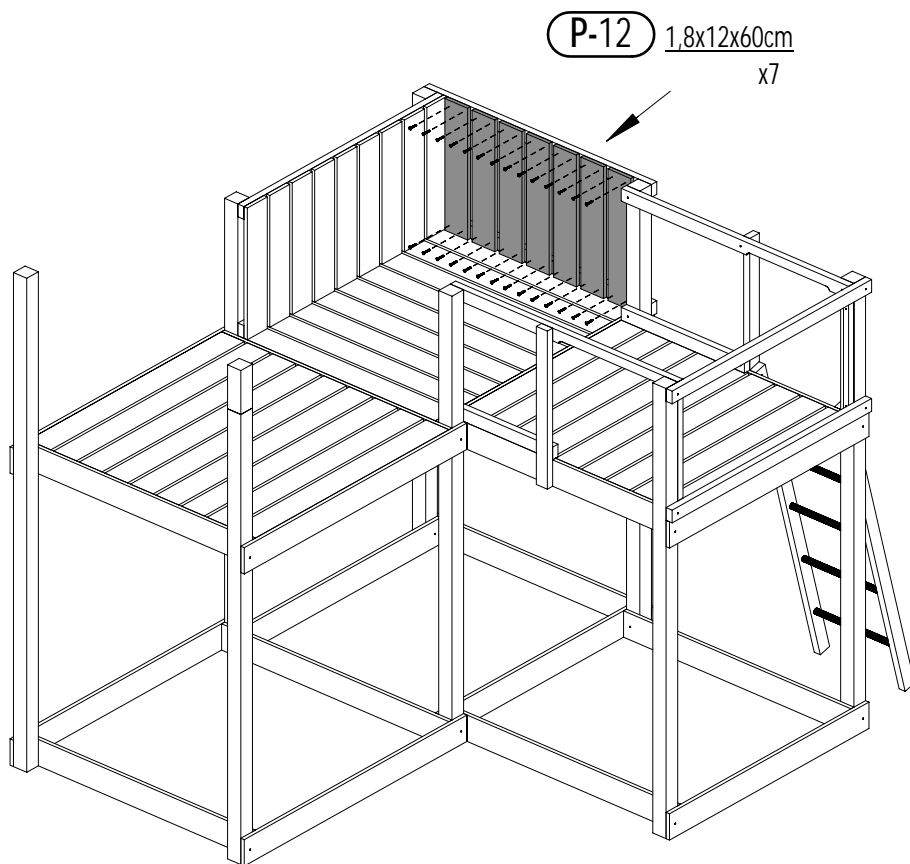

48

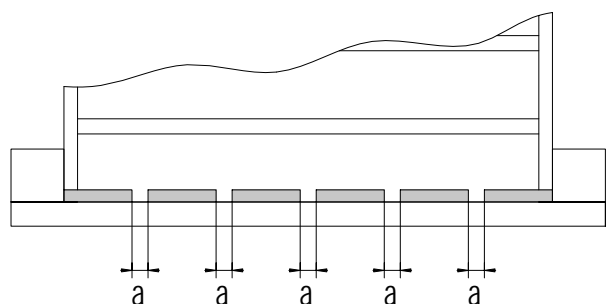
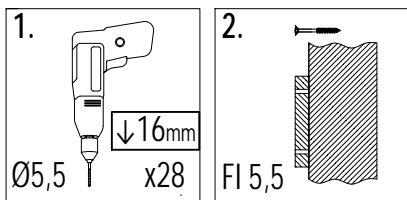

!!!min 13mm < **a** <!!!max 19mm

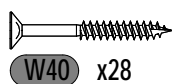
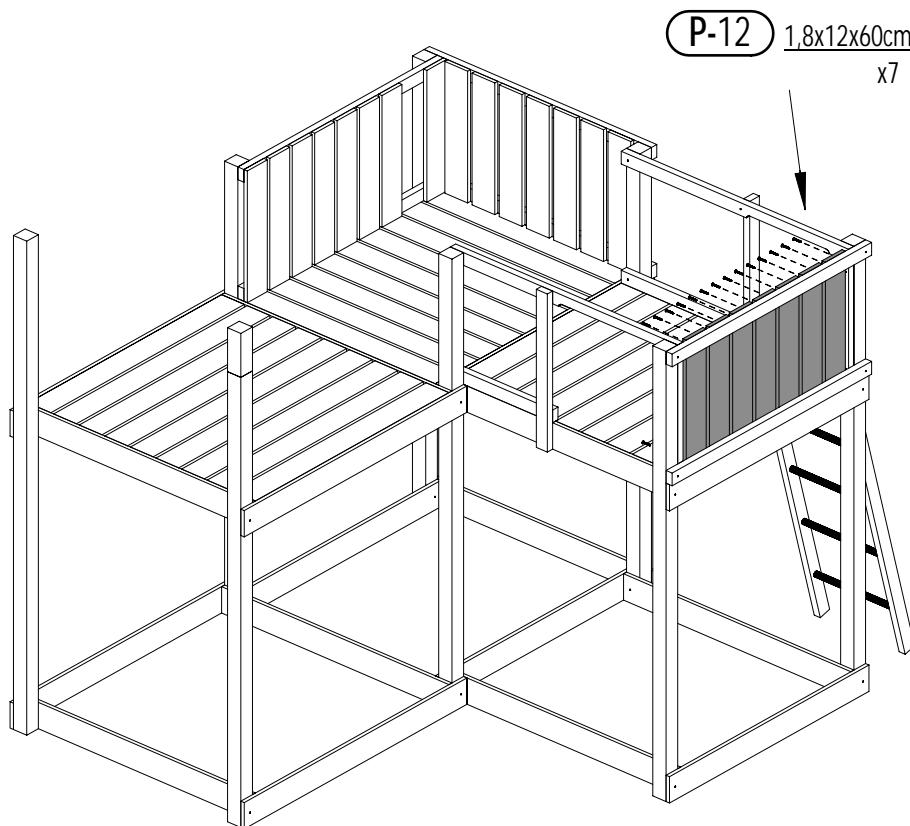

P-12 1,8x12x60cm
x3

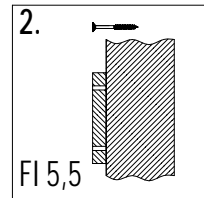
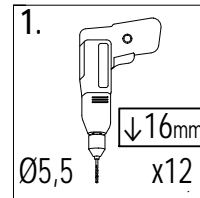
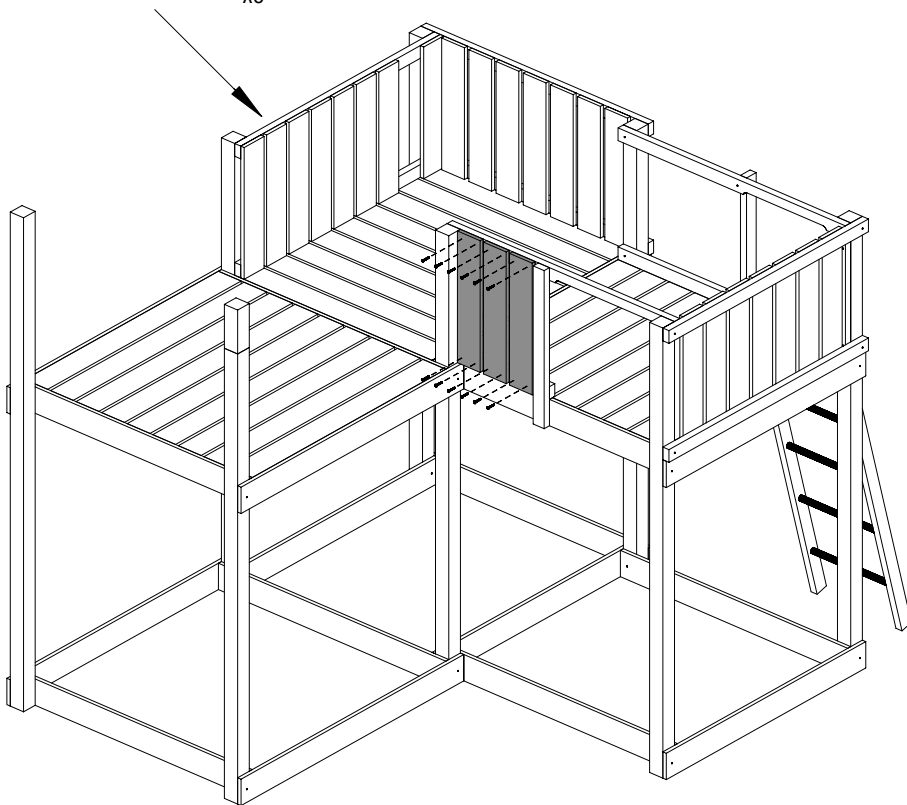

49

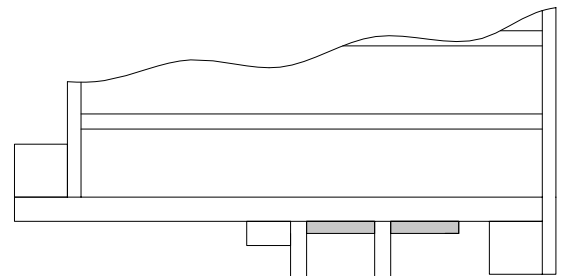

!!!min 13mm < **a** <!!!max 17mm

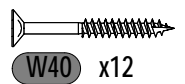

P-12 1,8x12x60cm
x4

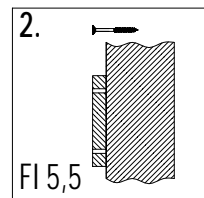
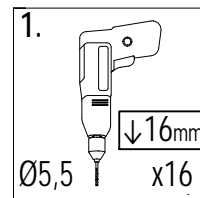
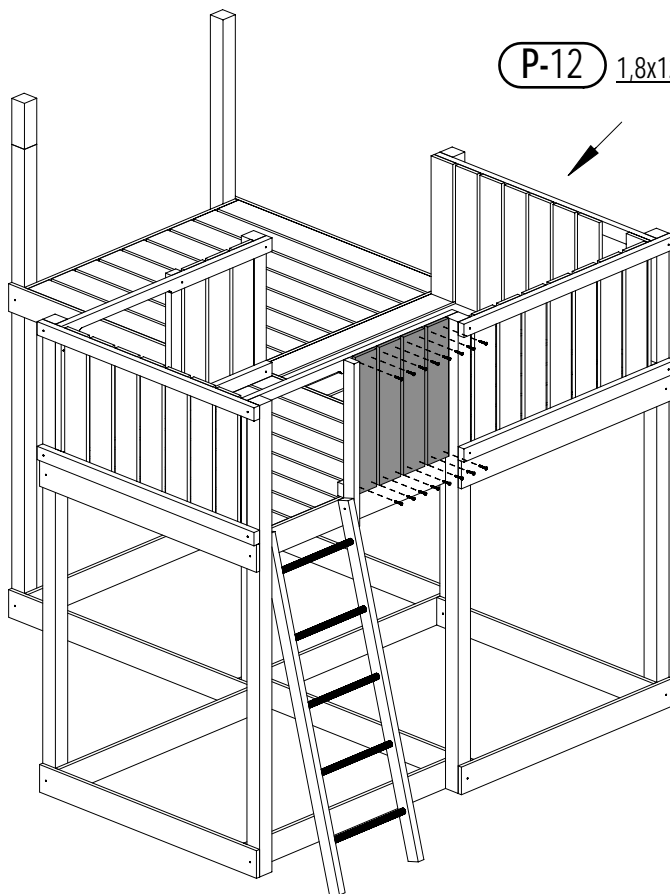

50

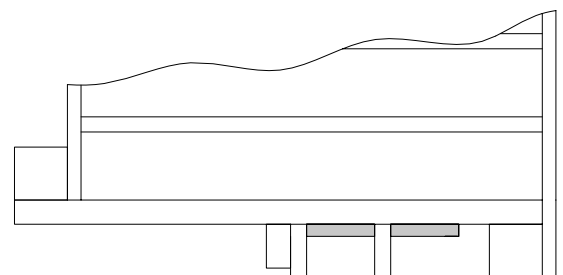

!!!min 13mm < **a** <!!!max 17

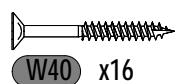

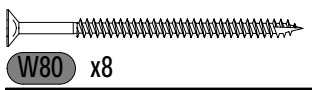
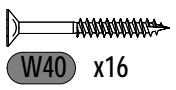
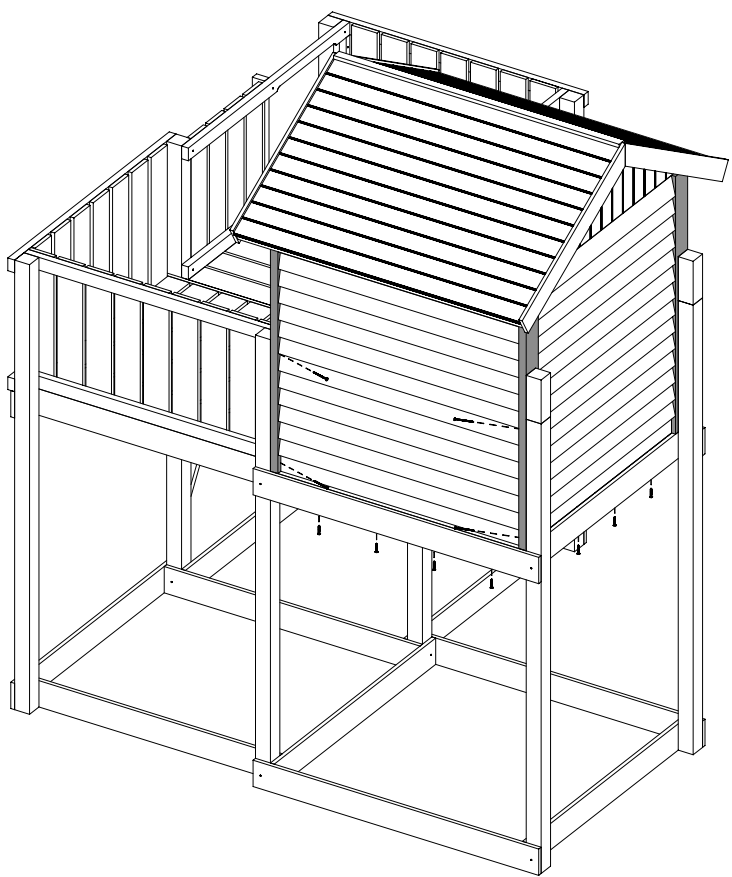
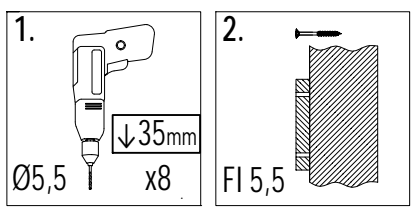
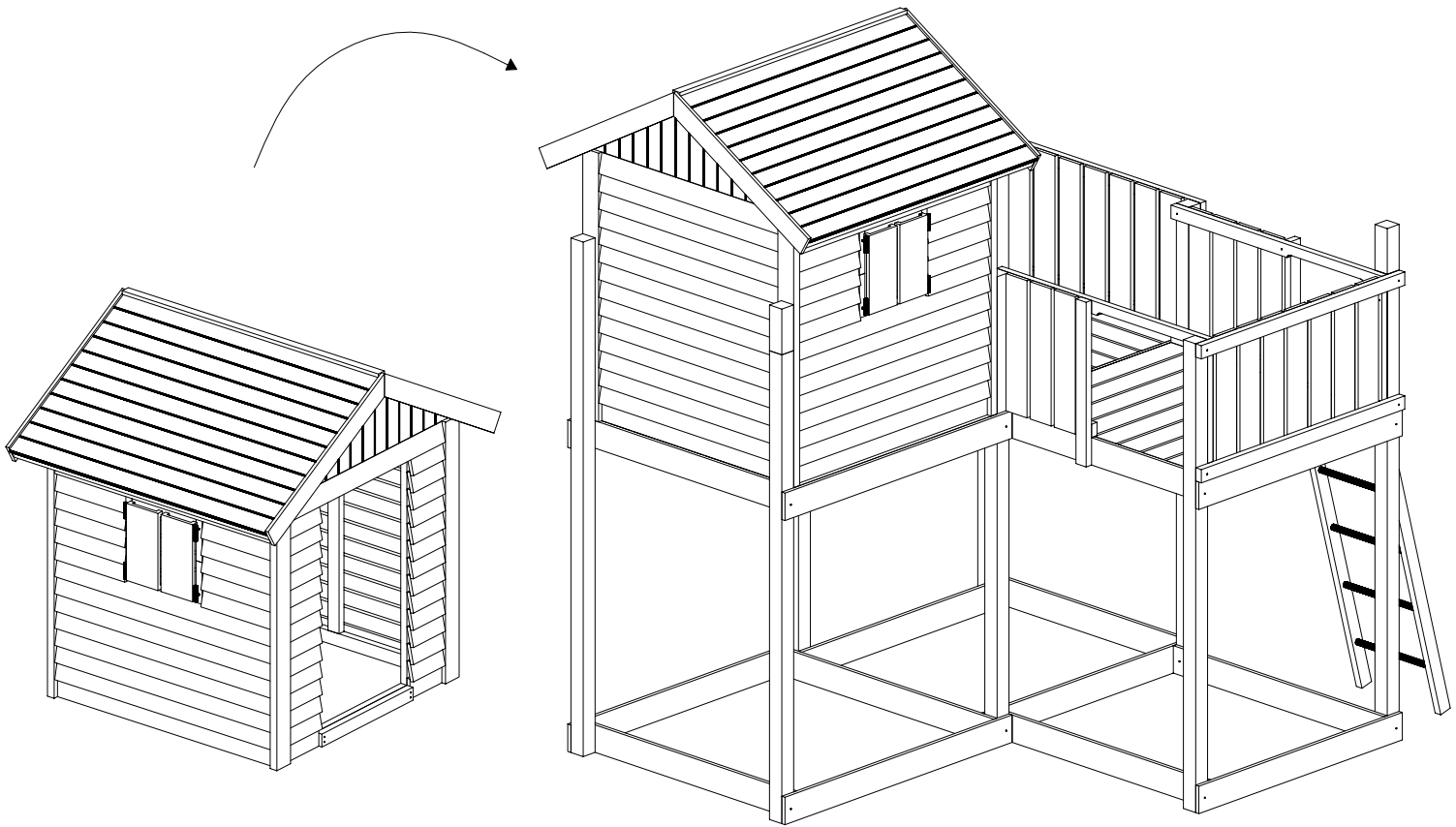

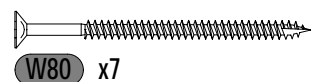
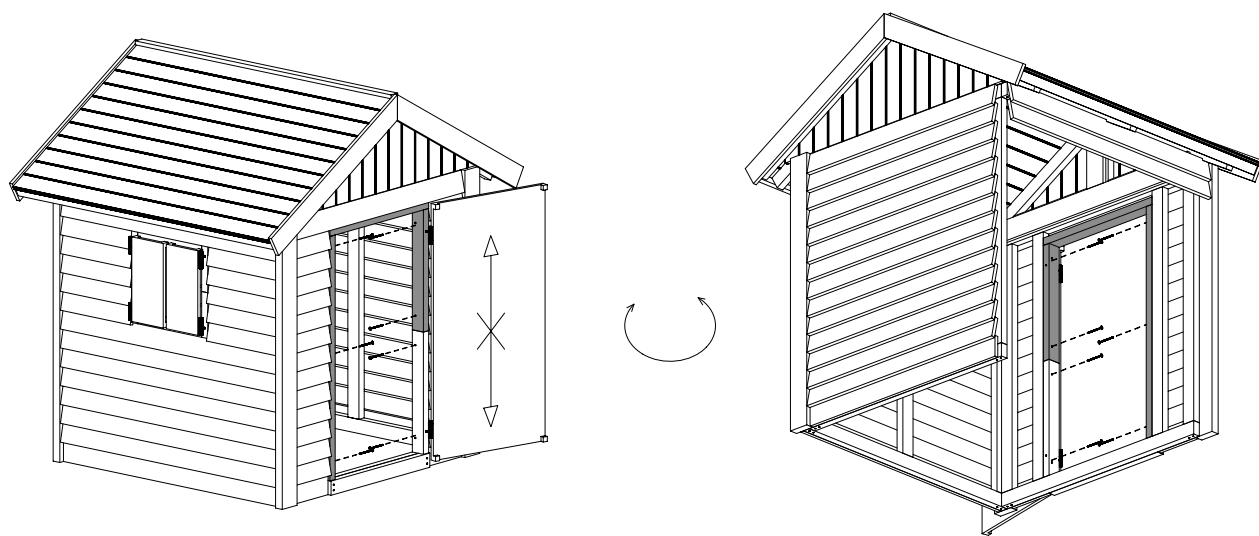
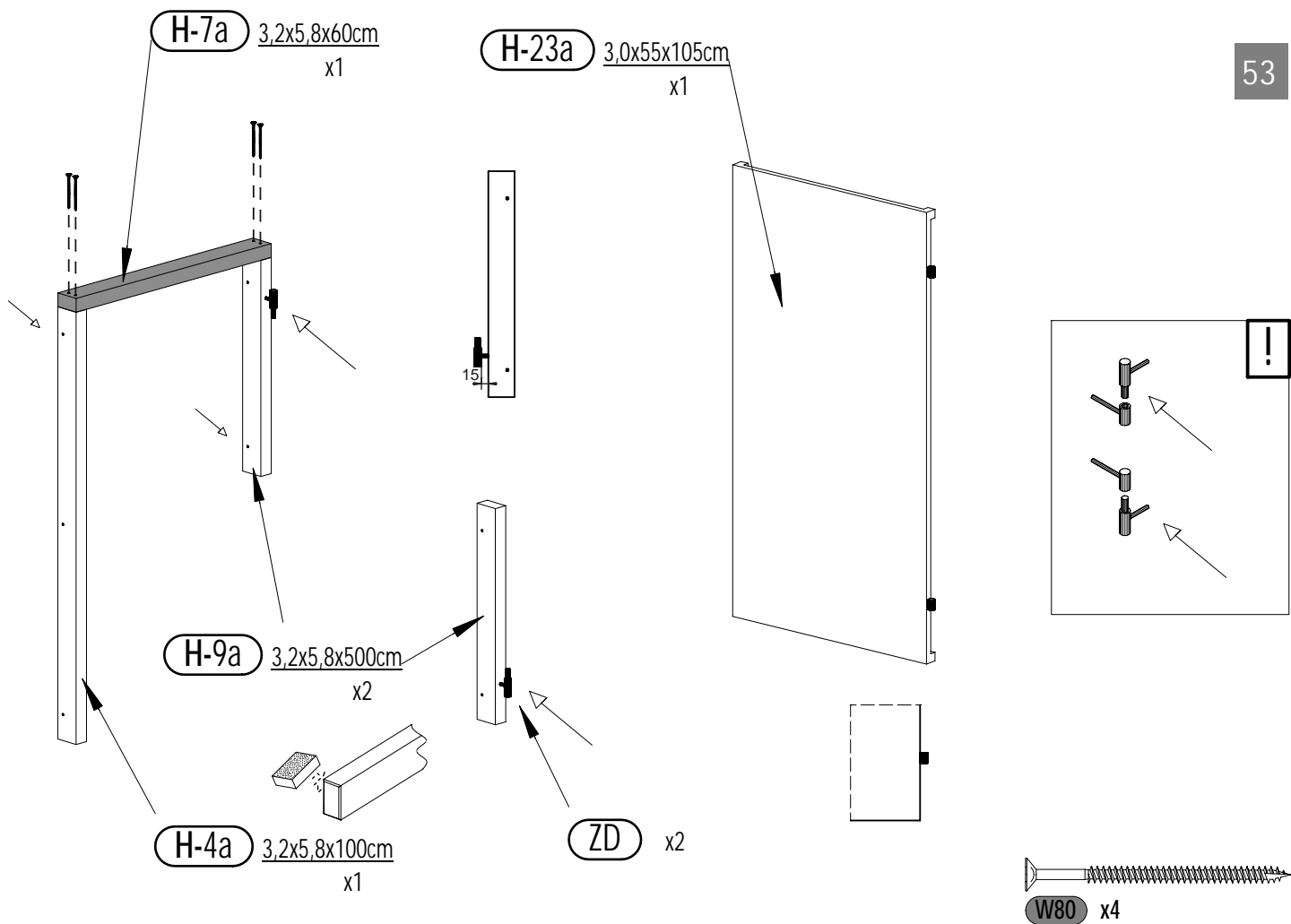

55

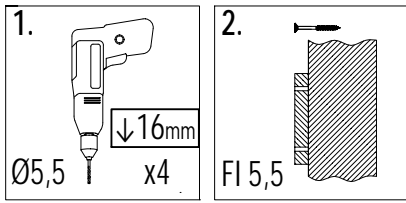

H-15 1,6x9,0x102cm x1

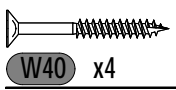
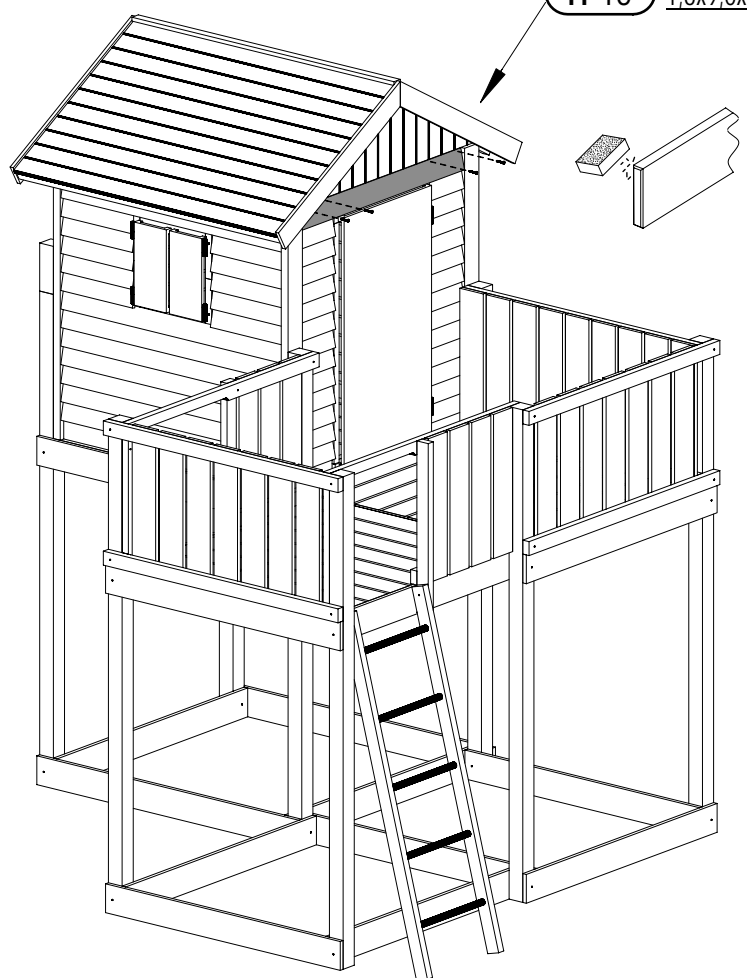

56

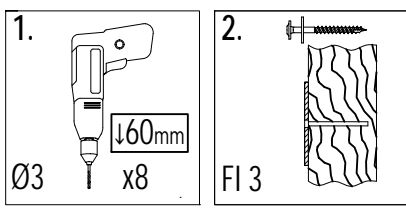

UC x4

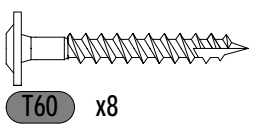
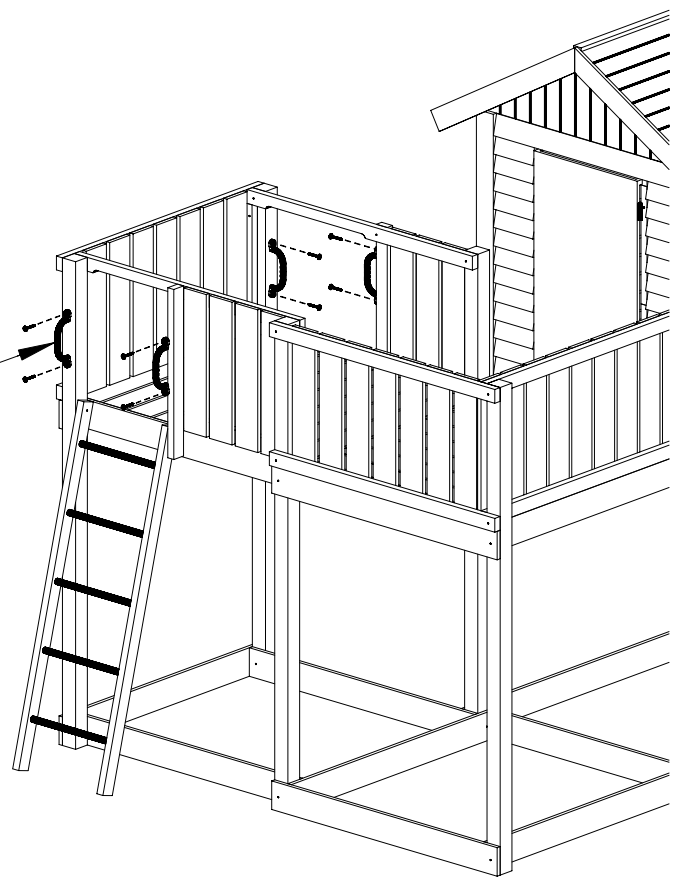

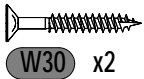
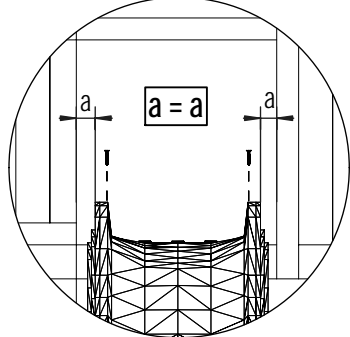
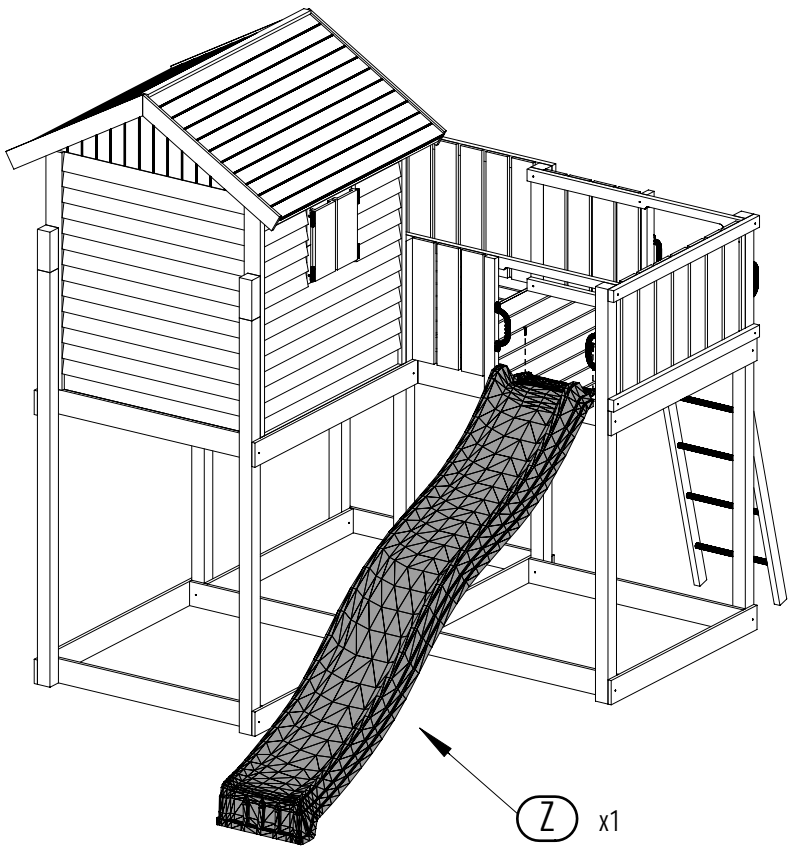
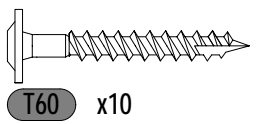
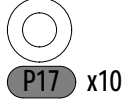
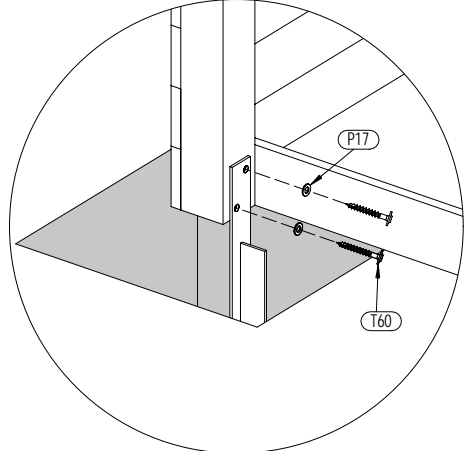
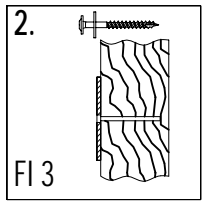
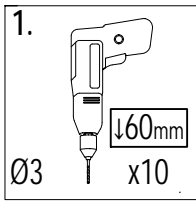
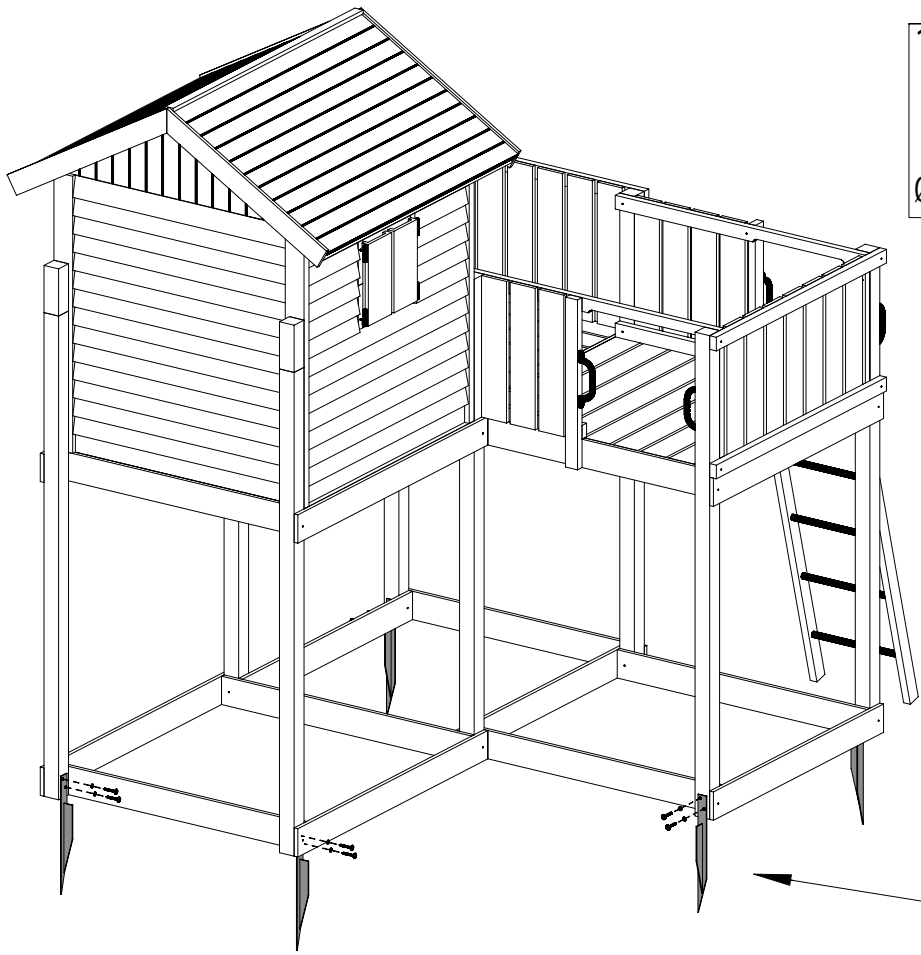

Zgodnie z normą PN-EN 71 stosuj zalecenia producenta odnośnie odległości oraz metody mocowania poszczególnych elementów
 In compliance with the standard PN-EN 71, apply guidelines of the producer in relation to distances and methods of fastening individual elements

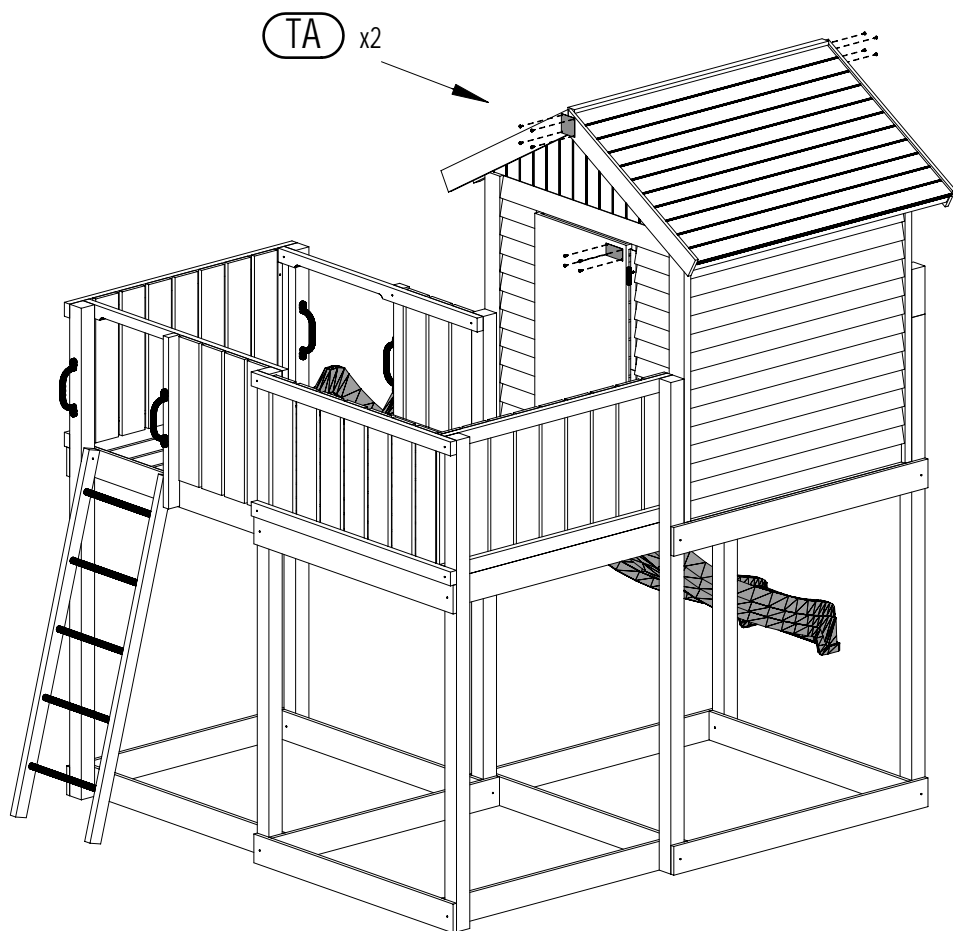
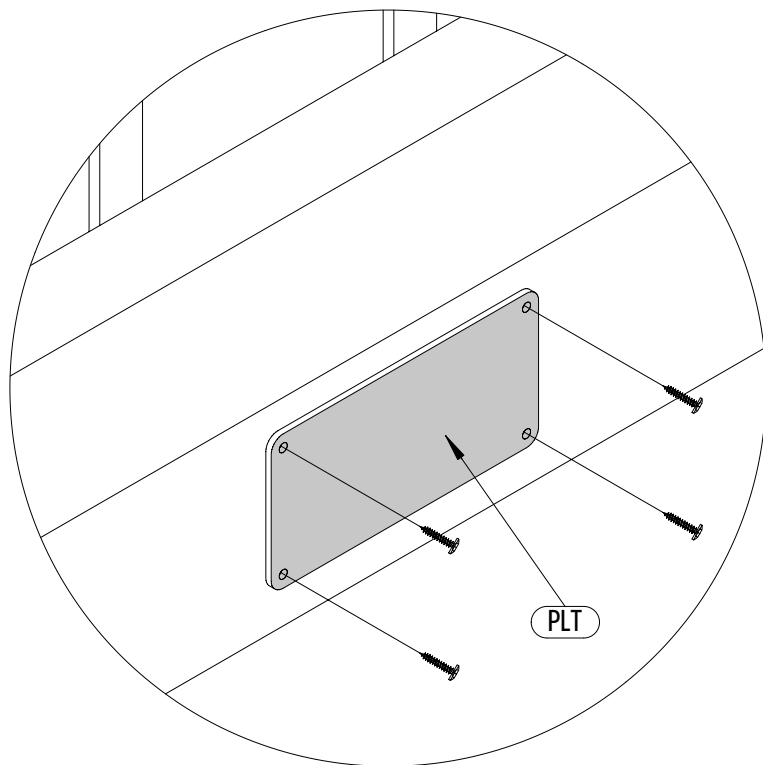

W20 x12