

PLAYGROUND SPIELPLATZ

PLAC ZABAW AIRE DE JEUX

(389 x 364 x h262cm)

003_08770_12012024

FLOPPI V2

INSTALLATION INSTRUCTIONS
MONTAGEANLEITUNG

INSTRUKCJA MONTAŻU
GUIDE D'INSTALLATION

Warranty period - 2 years from purchase date

Garantiezeit - 2 Jahre ab Kaufdatum

Okres gwarancji - 2 lata od momentu zakupu towaru

Période de garantie - 2 ans à compter de l'achat

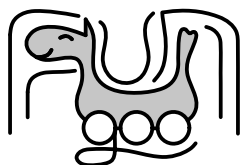

fungoo®

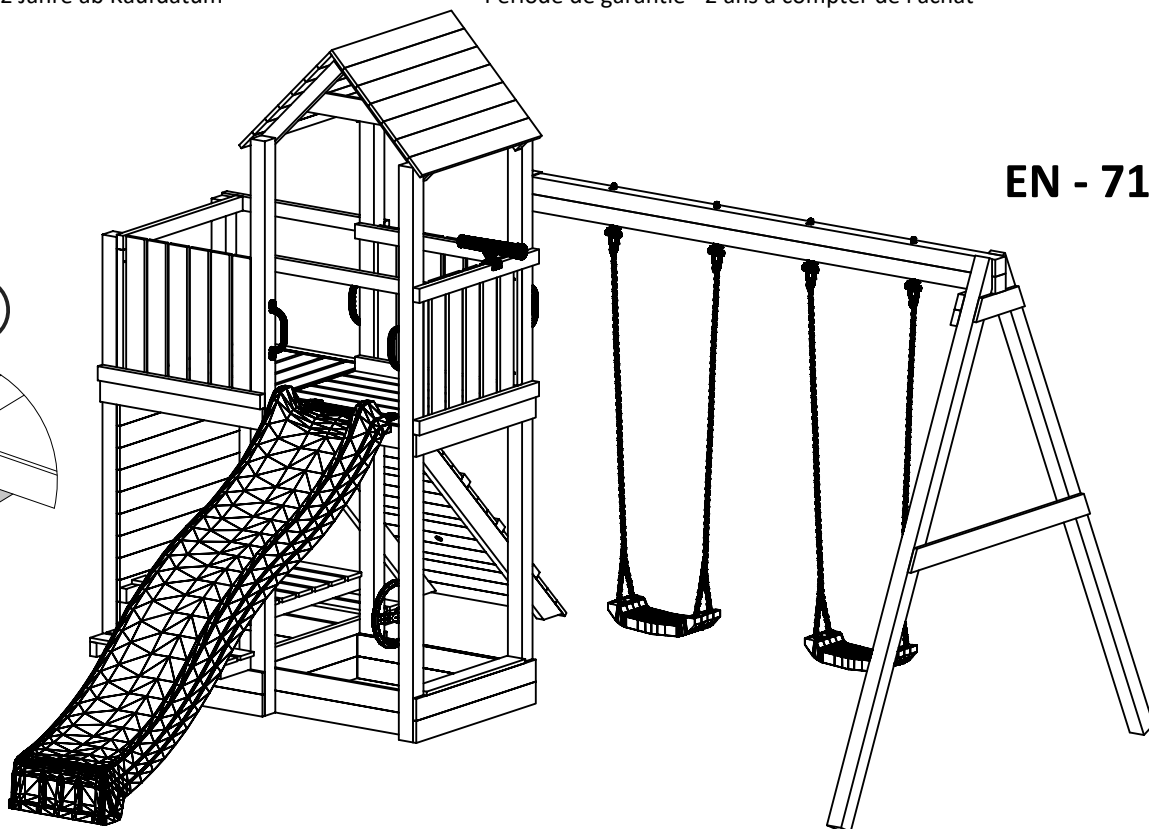
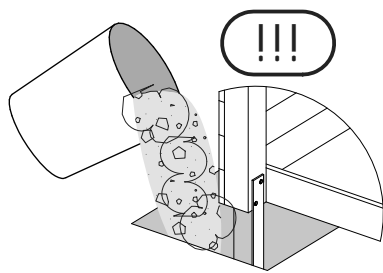

EN - 71

WARNINGS!

Only for home use.

Dedicated for external use only.

Not suitable for children under 3 years old.

Risk of falling down and/or hitting.

Maximum user weight is up to 50 kg.

Maximum number of users staying on the playground at the same time: 7.

OSTRZEŻENIA!

Tylko do użytku domowego.

Przeznaczony do użytku na zewnątrz.

Nie przeznaczony dla dzieci poniżej 3 roku życia.

Niebezpieczeństwo upadku i/lub uderzenia.

Maksymalna waga użytkownika to 50 kg.

Maksymalna liczba użytkowników przebywających na placu zabaw w tym samym czasie: 7.

ACHTUNG!

Nur für den privaten, häuslichen Bereich.

Ausschließlich für die Verwendung im Freien.

Nicht geeignet für Kinder unter 3 Jahren.

Stolper- und / oder Sturzgefahr

Höchstgewicht pro Einzelkind beträgt 50 kg

Der Aufenthalt auf diesem Spielturm ist max. : 7.

Kindern gleichzeitig erlaubt.

AVERTISSEMENT!

Aire exclusivement destinée à un usage privé.

Aire exclusivement destinée à un usage en extérieur.

Prévue pour les enfants de plus de 3 ans.

Danger de chute ou de choc.

Poids maximal d'un utilisateur : 50 kg.

Nombre maximal d'utilisateurs présents en même temps sur la même aire de jeux: 7.

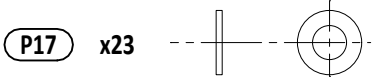
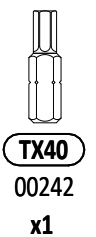
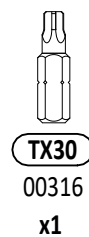
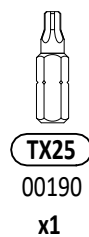
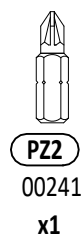
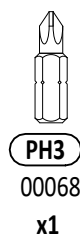
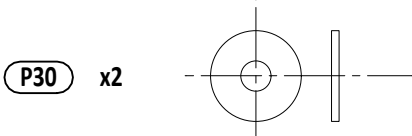
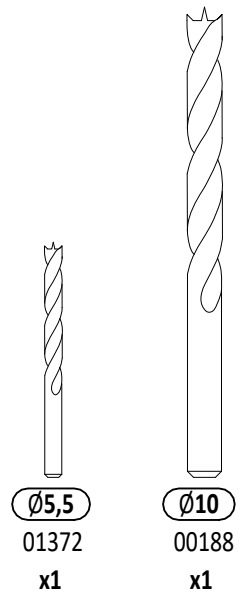
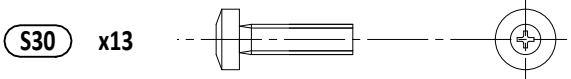
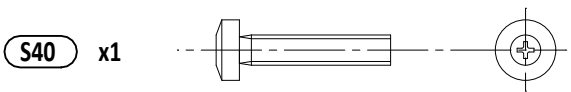
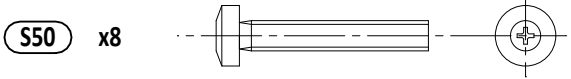
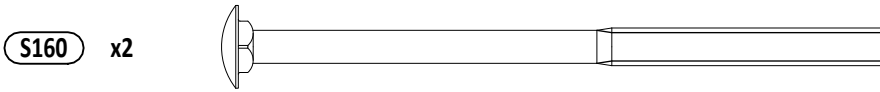
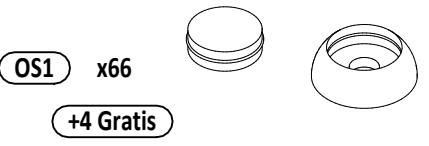
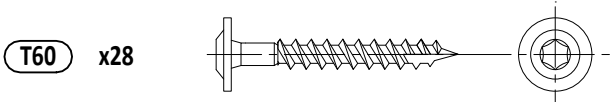
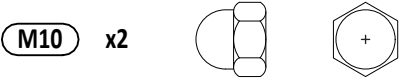
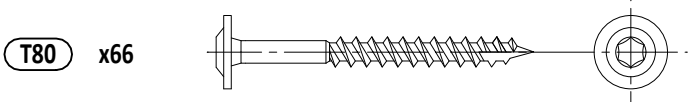
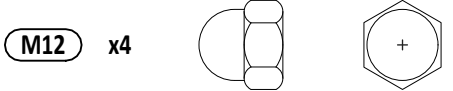
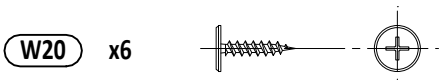
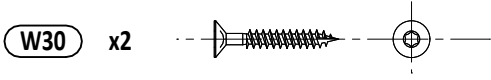
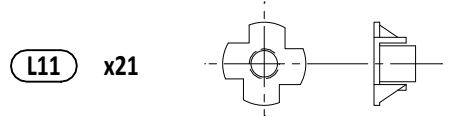
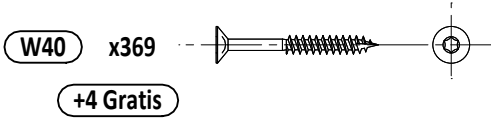
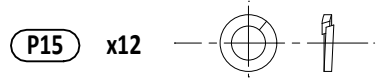
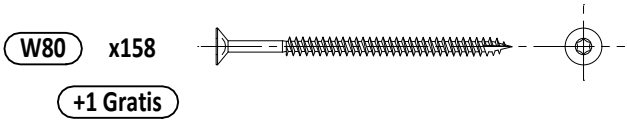

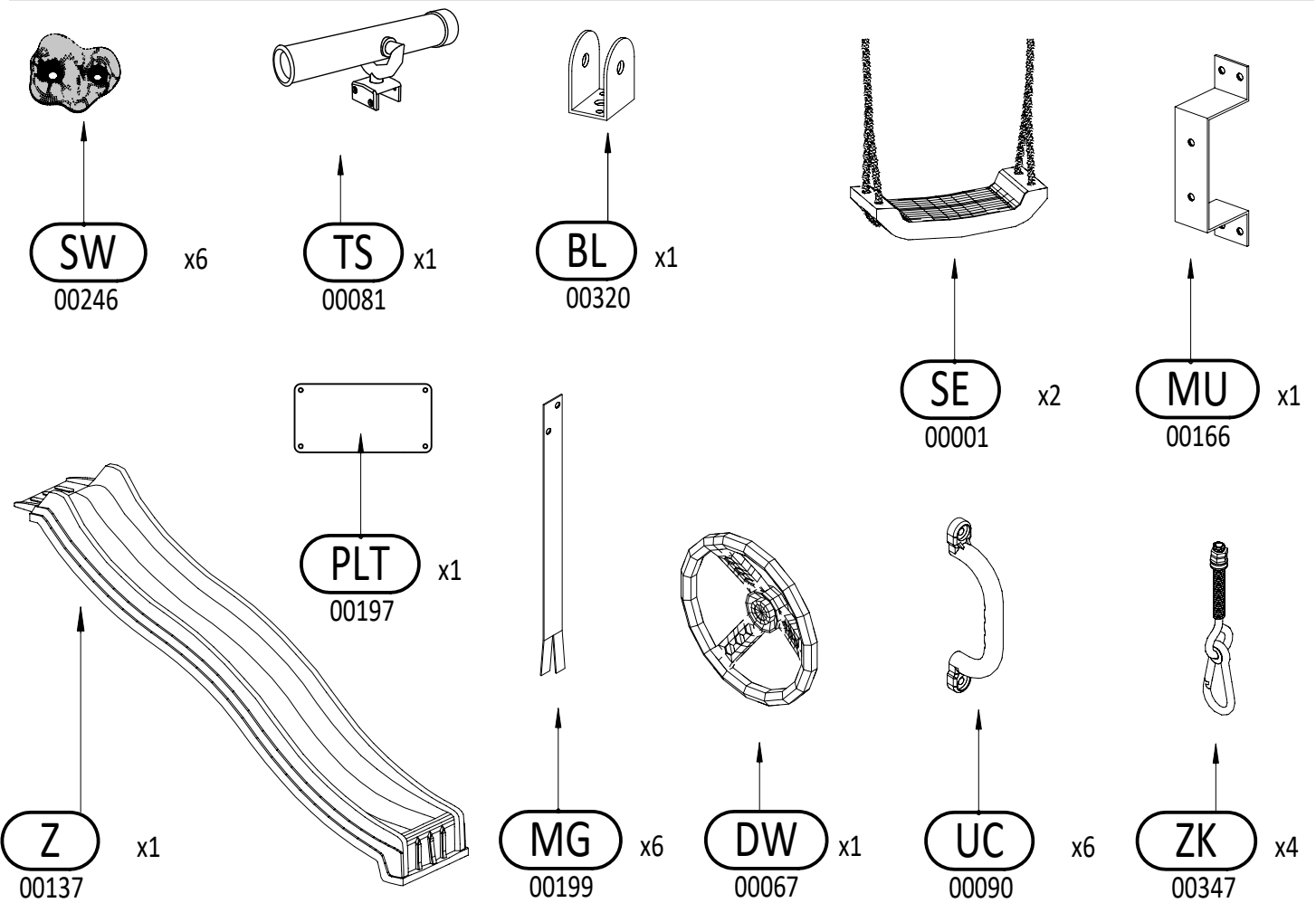
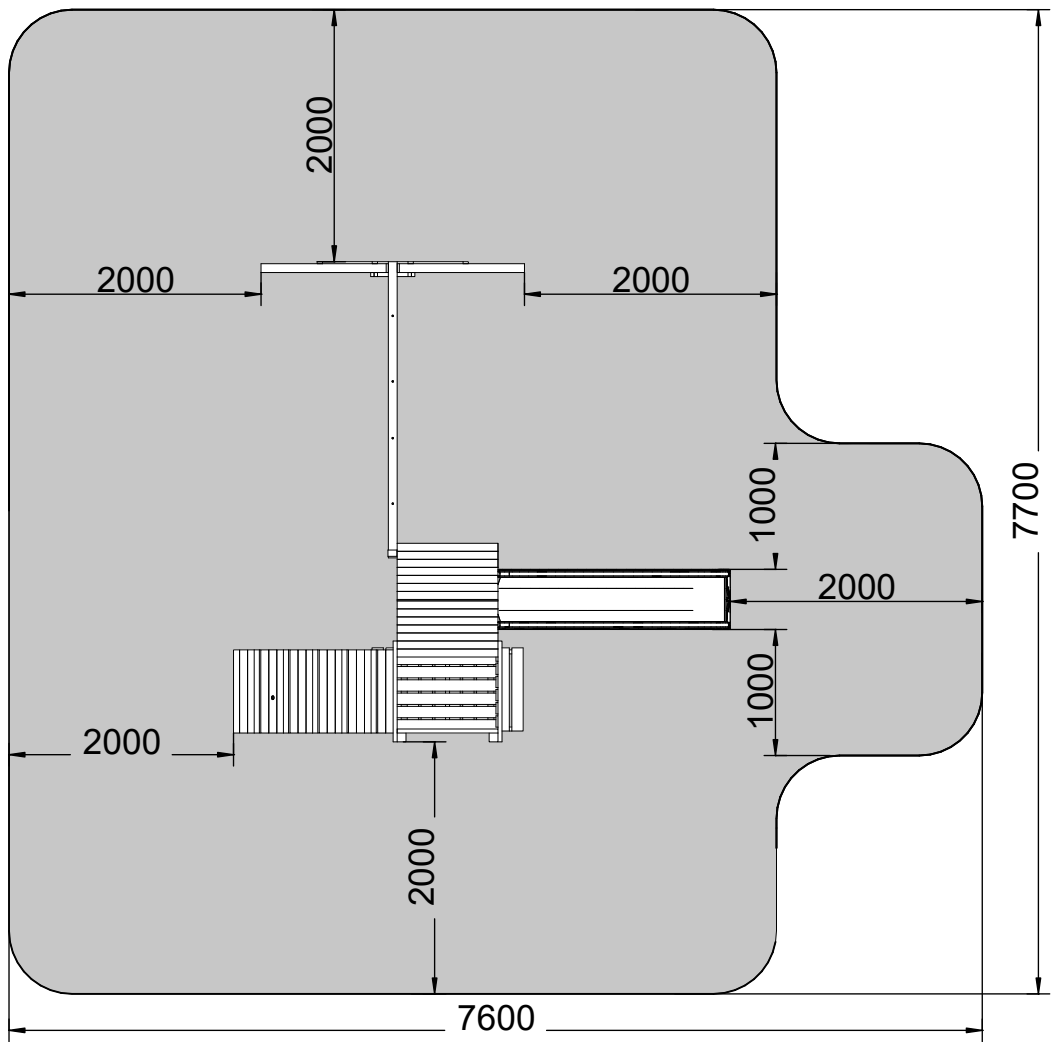
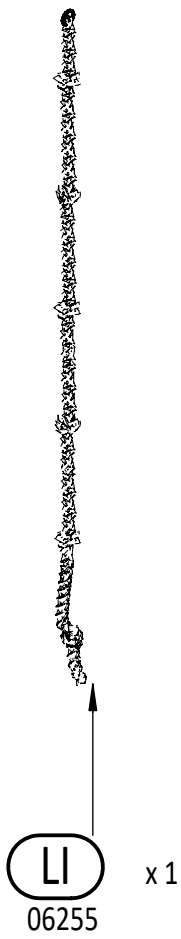

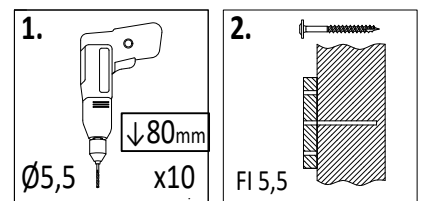
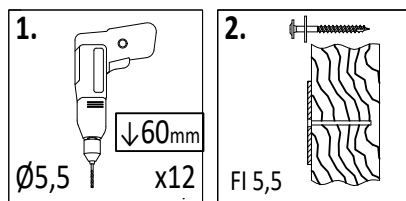
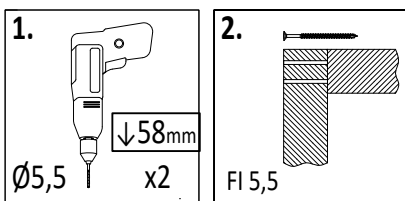
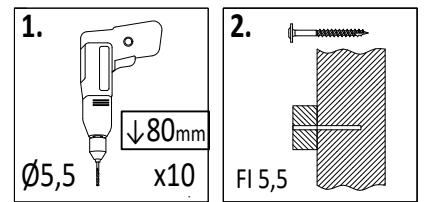
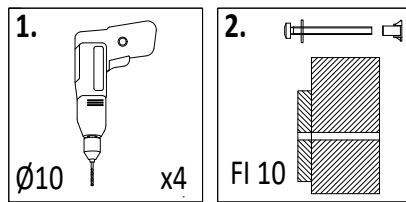
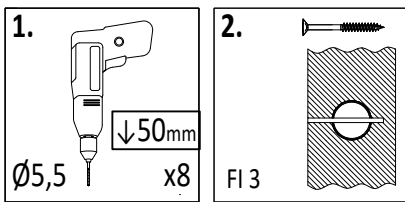
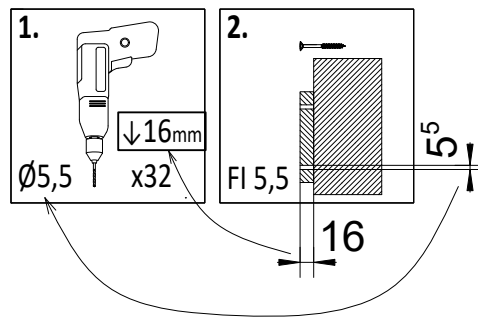
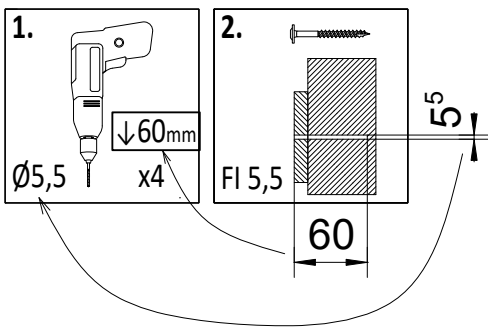
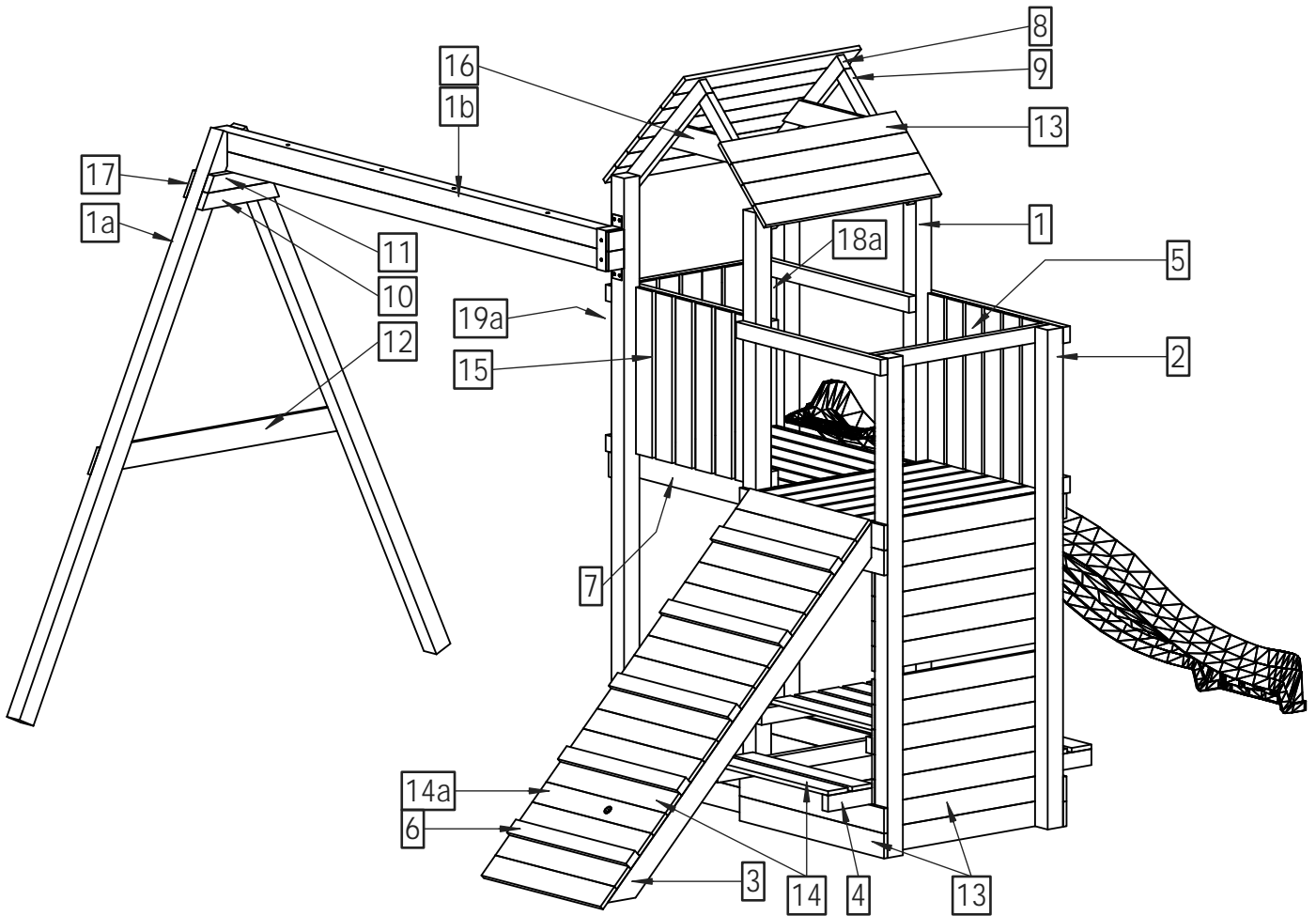

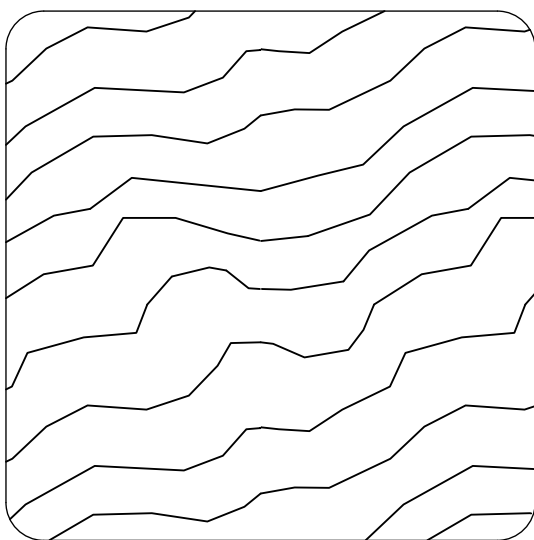

7,0 x 7,0 cm

| Lp. | Kod | Wymiary [mm] | sz. |
|-----|-------|--------------|-----|
| 1 | 03901 | 70x70x2200mm | 4 |
| 1a | 06453 | 70x70x2200mm | 2 |
| 1b | 06467 | 70x70x2200mm | 2 |
| 2 | 05245 | 70x70x1800mm | 2 |

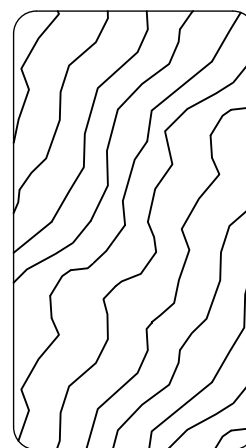

3,2 x 5,8 cm

| Lp. | Kod | Wymiary [mm] | sz. |
|-----|-------|--------------|-----|
| 4 | 03889 | 32x58x1200mm | 2 |
| 5 | 04457 | 32x58x800mm | 11 |
| 6 | 04182 | 32x58x660mm | 5 |
| 7 | 04459 | 32x58x628mm | 6 |
| 8 | 04617 | 32x58x610mm | 2 |
| 9 | 04619 | 32x58x550mm | 2 |
| 10a | 04461 | 32x58x350mm | 1 |
| 11a | 04463 | 32x58x296mm | 1 |



1,6 x 9,0 cm

| Lp. | Kod | Wymiary [mm] | sz. |
|-----|-------|--------------|-----|
| 12a | 03920 | 16x90x1200mm | 1 |
| 13 | 04465 | 16x90x800mm | 59 |
| 14 | 04096 | 16x90x660mm | 27 |
| 14a | 04098 | 16x90x660mm | 1 |
| 15 | 04625 | 16x90x600mm | 18 |
| 16a | 04467 | 16x90x560mm | 2 |
| 17a | 04469 | 16x90x325mm | 1 |

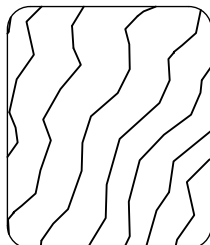

2,7 x 3,2 cm

| Lp. | Kod | Wymiary [mm] | sz. |
|-----|-------|--------------|-----|
| 18a | 04471 | 27x32x542mm | 2 |
| 19a | 04476 | 27x32x484mm | 1 |

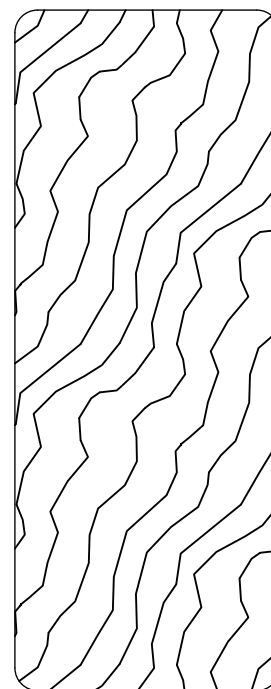

3,5 x 9,0 cm

| Lp. | Kod | Wymiary [mm] | sz. |
|-----|-------|--------------|-----|
| 3a | 08445 | 35x90x1700mm | 2 |

01

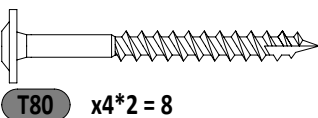
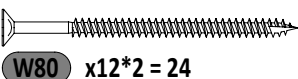
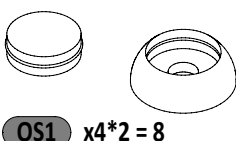
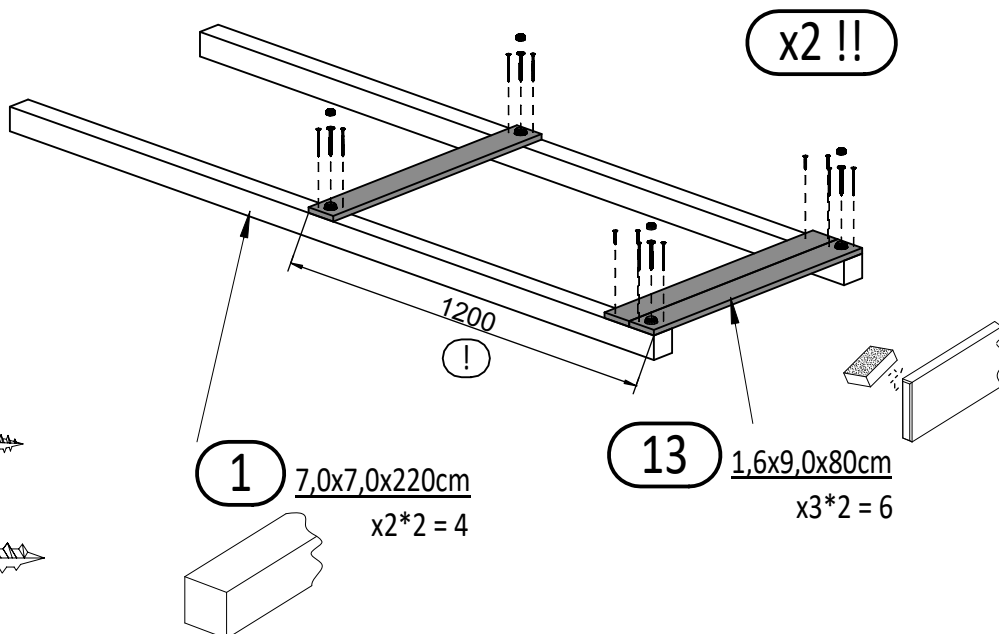
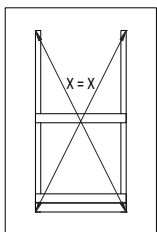
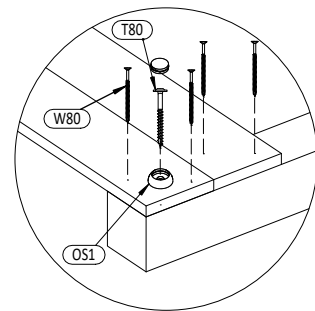
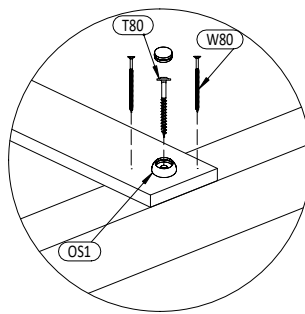
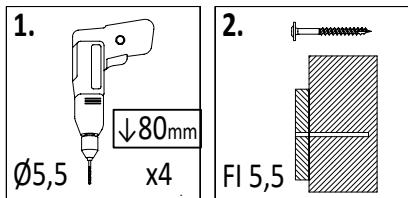

02

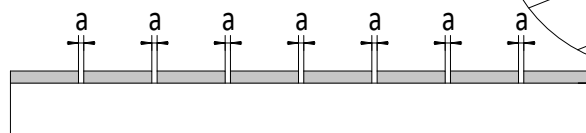
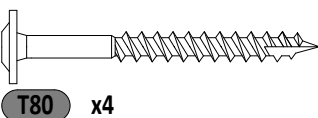
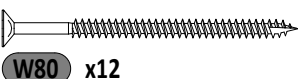
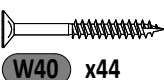
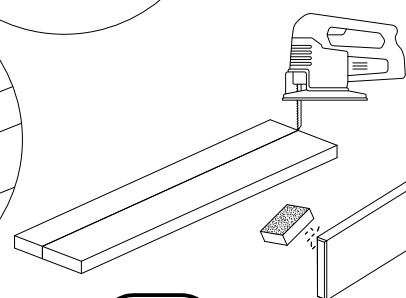
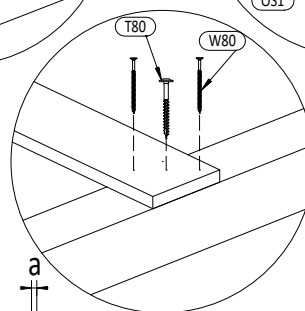
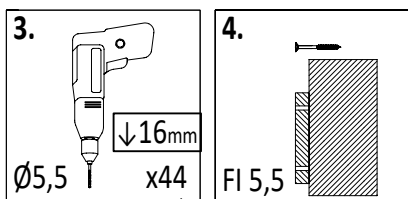
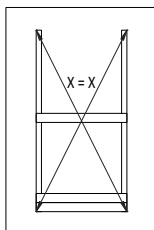
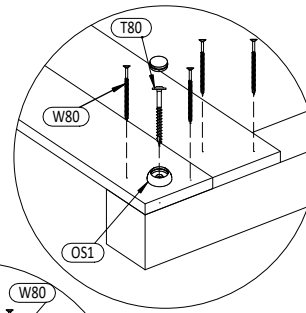
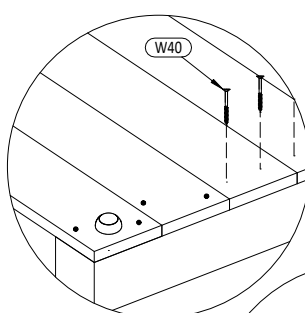
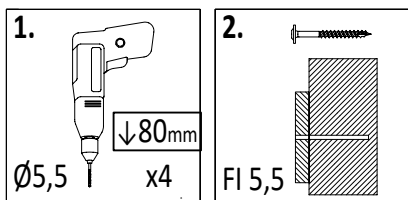

!!!min 2mm < a < !!!max 6mm

13 1,6x9,0x80cm x13

2 7,0x7,0x180cm x2

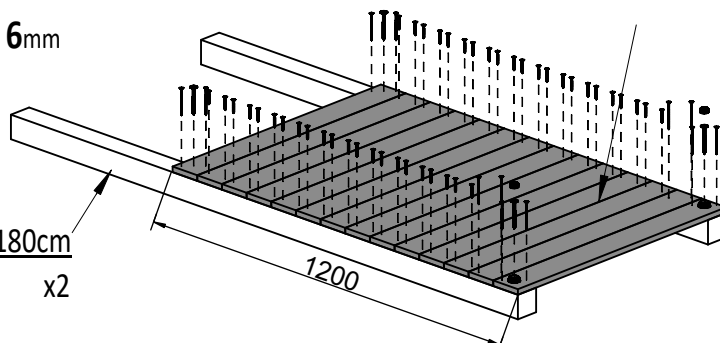

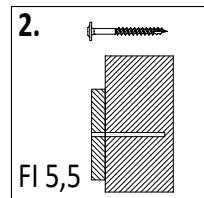
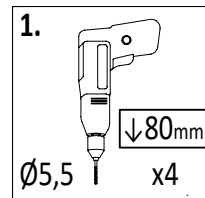
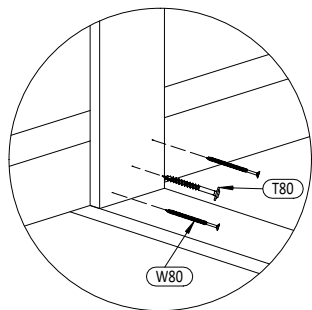

13 1,6x9,0x80cm

x6

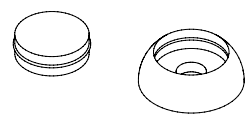
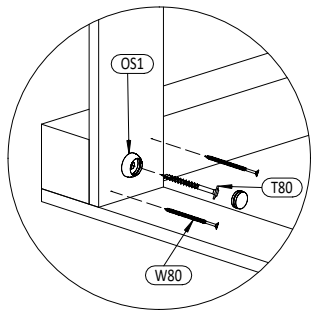
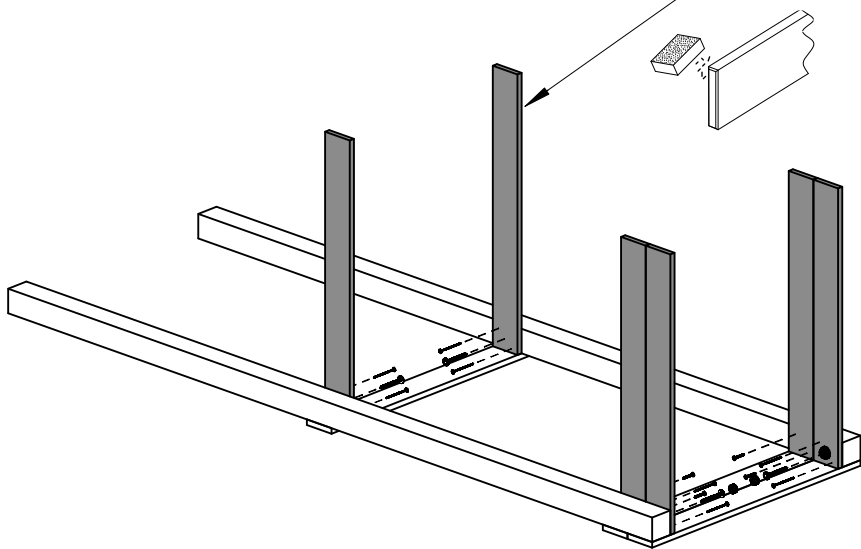

OS1 x2

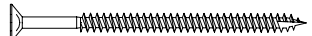

W80 x12



T80 x4

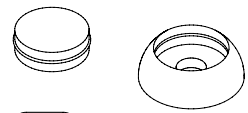
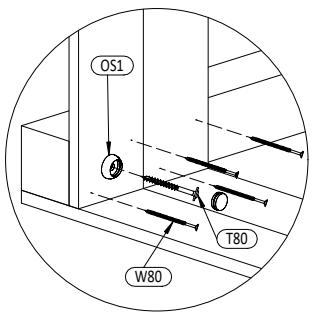
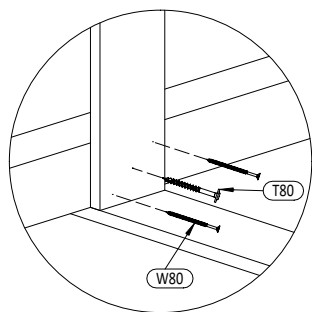
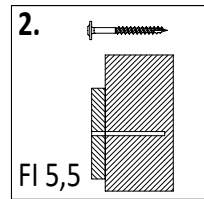
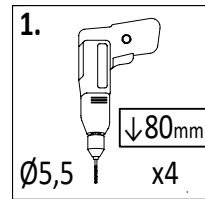
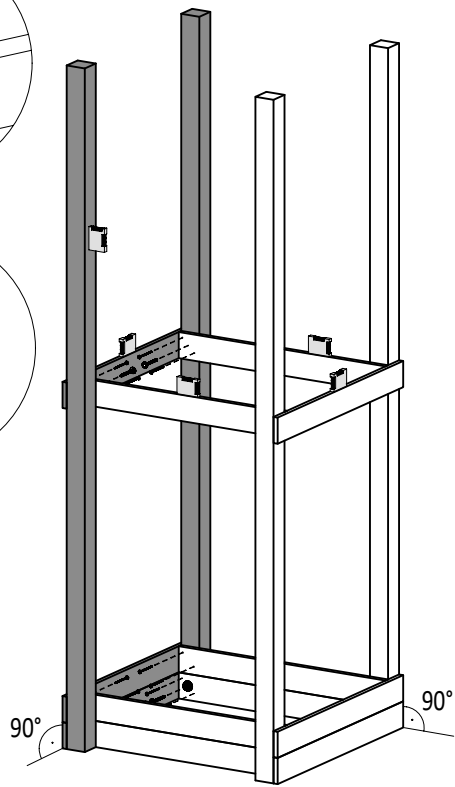
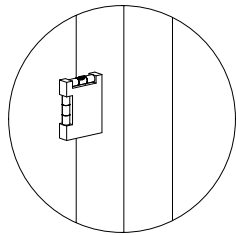
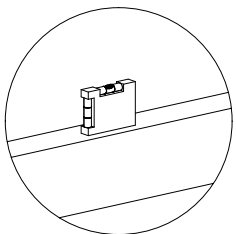

OS1 x2

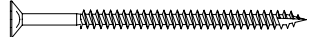

W80 x12

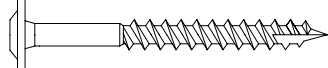

T80 x4

05

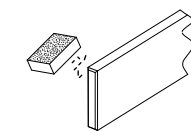
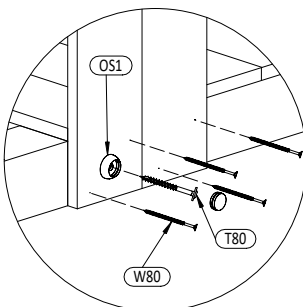
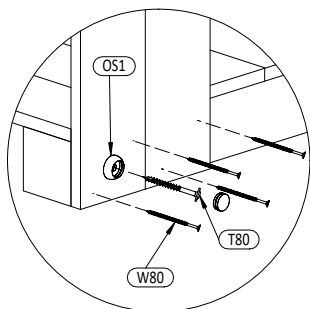
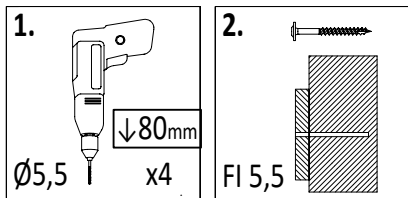

13 1,6x9,0x80cm
x7

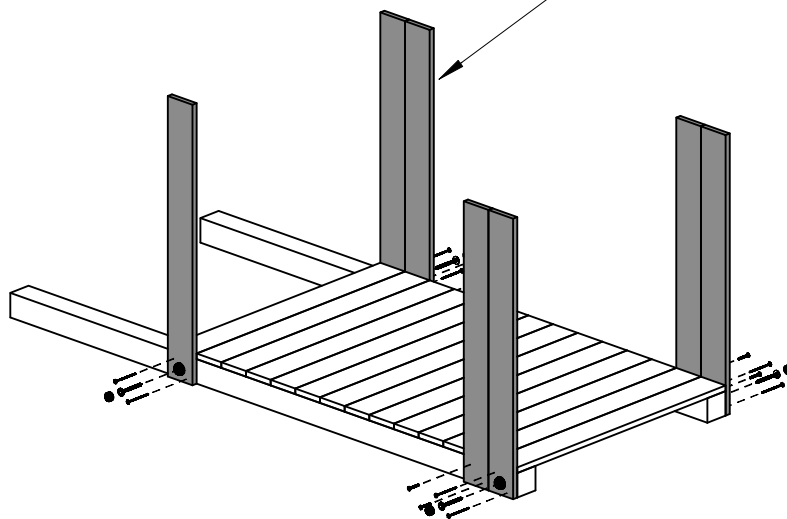

OS1 x4

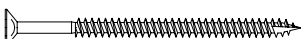

W80 x14

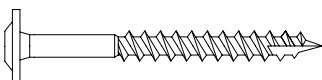

T80 x4

06

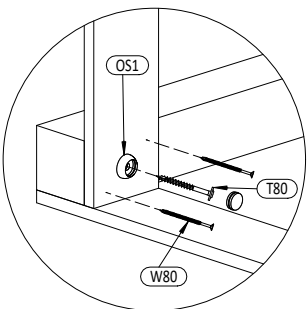
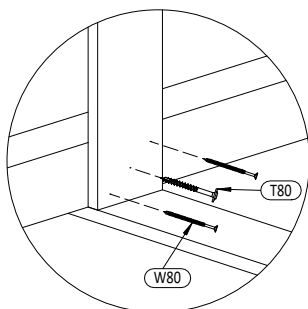
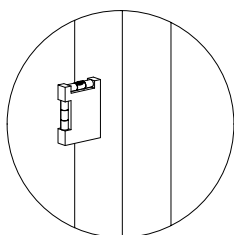
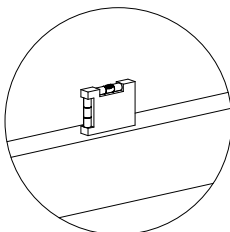
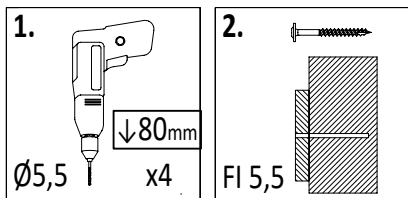

OS1 x4



W80 x14

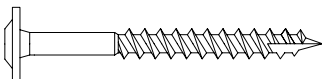

T80 x4

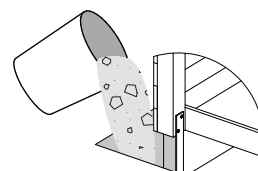
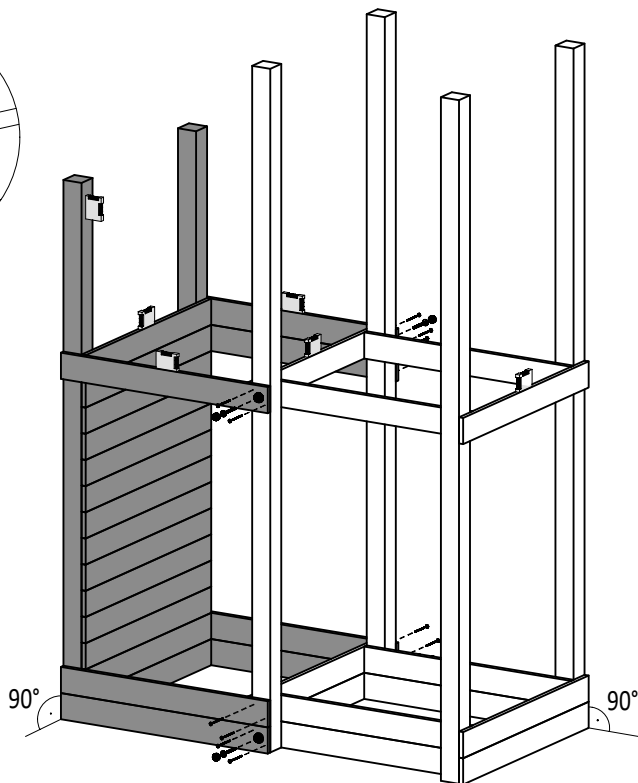

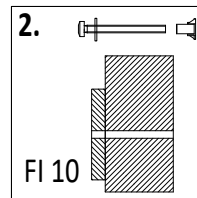
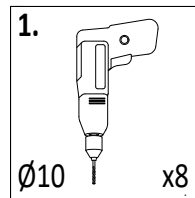
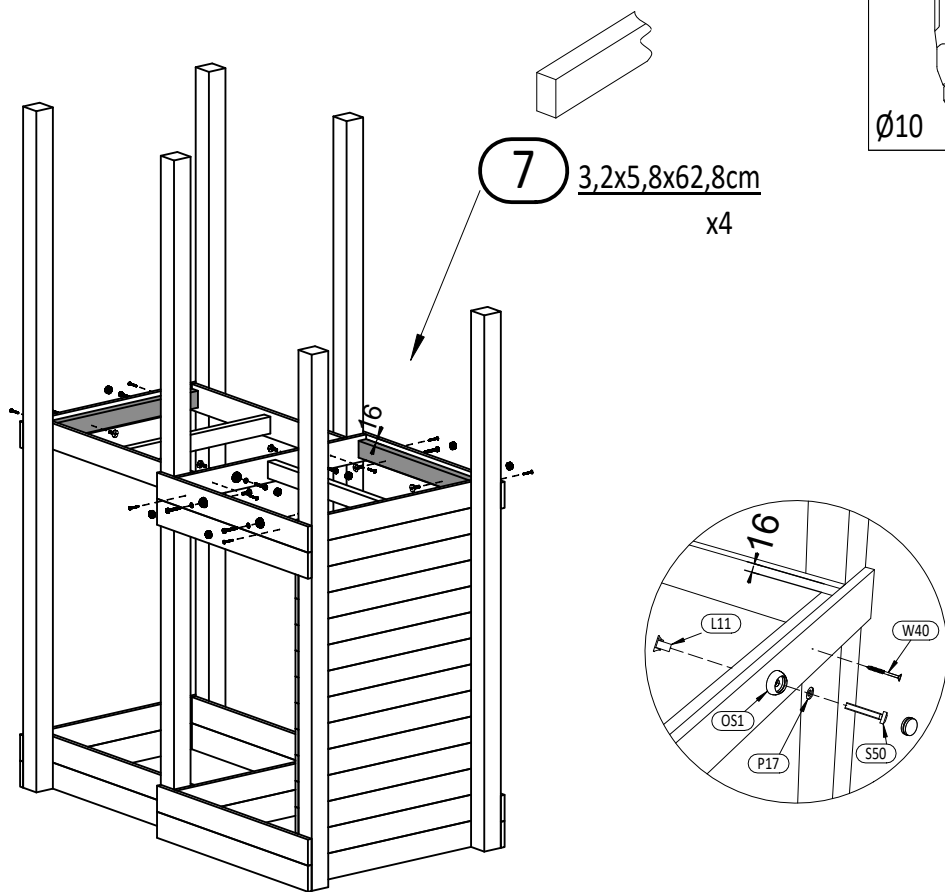
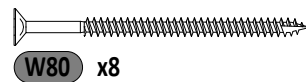
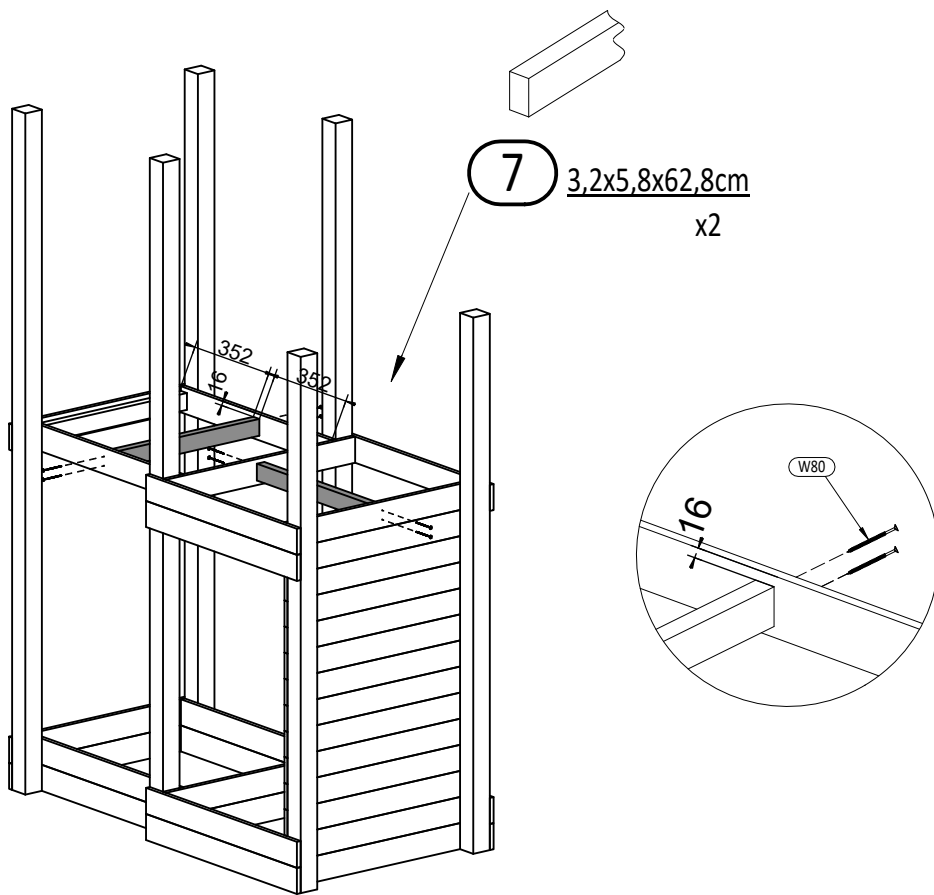

OS1 x8

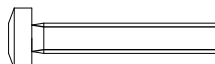
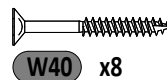

S50 x8

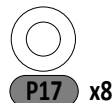

P17 x8



L11 x8

09

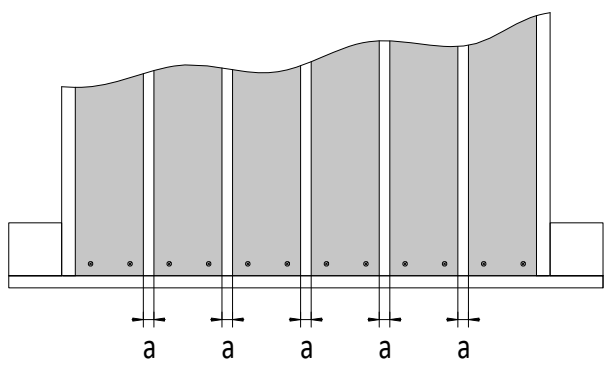
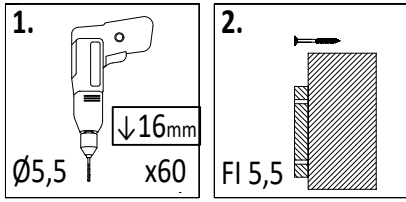

!!!min 13mm < a < !!!max 18mm

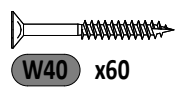

13 1,6x9,0x80cm x12

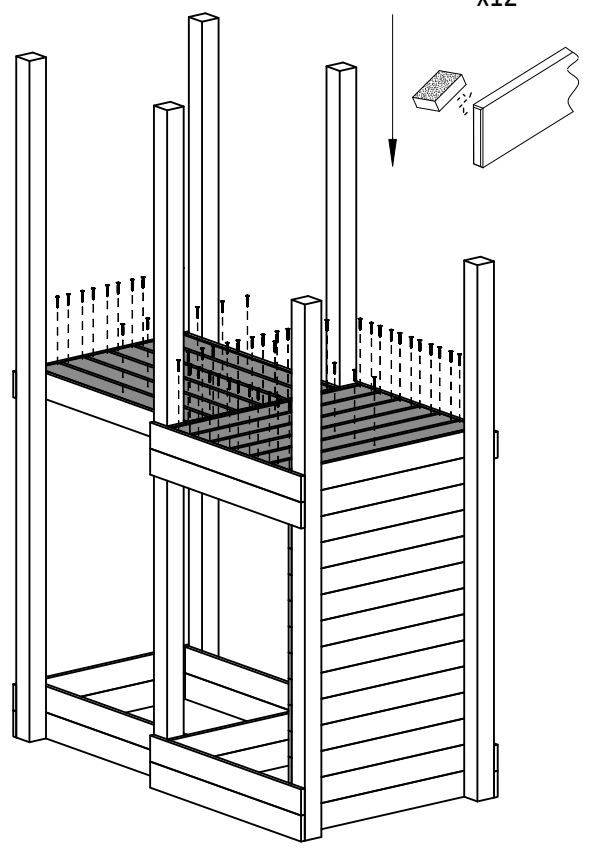

10

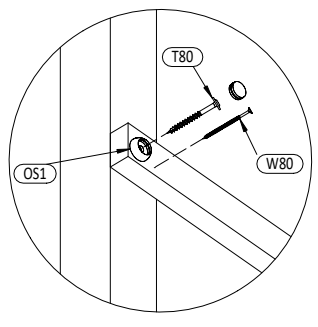
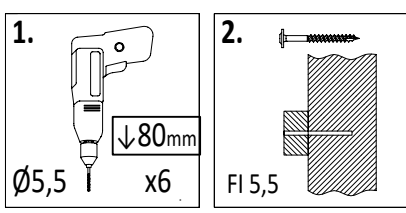

5 3,2x5,8x80cm x3

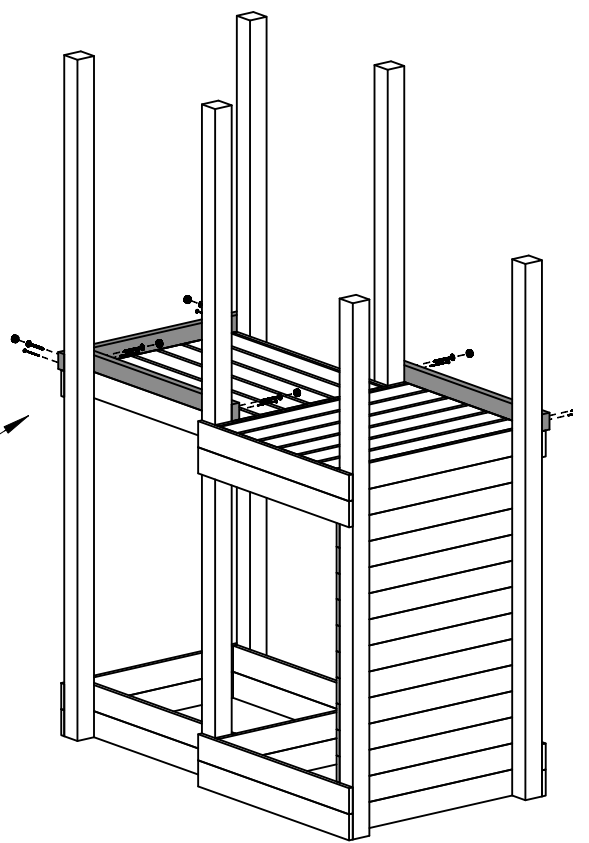
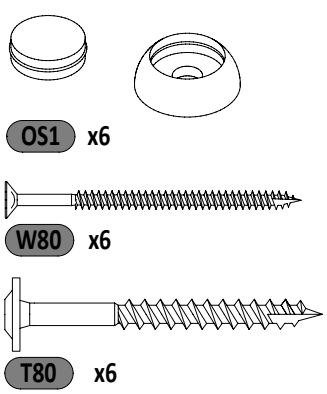

10 FLOPPI V2

Zgodnie z normą PN-EN 71 stosuj zalecenia producenta odnośnie odległości oraz metody mocowania poszczególnych elementów
In compliance with the standard PN-EN 71, apply guidelines of the producer in relation to distances and methods of fastening individual elements

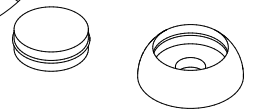
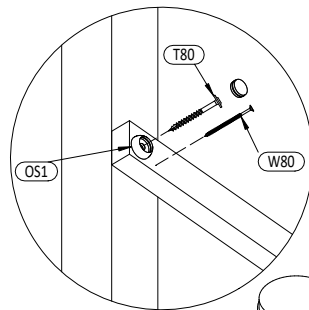
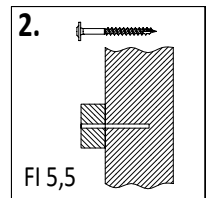
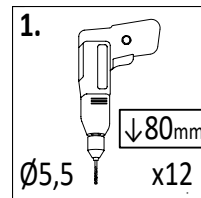
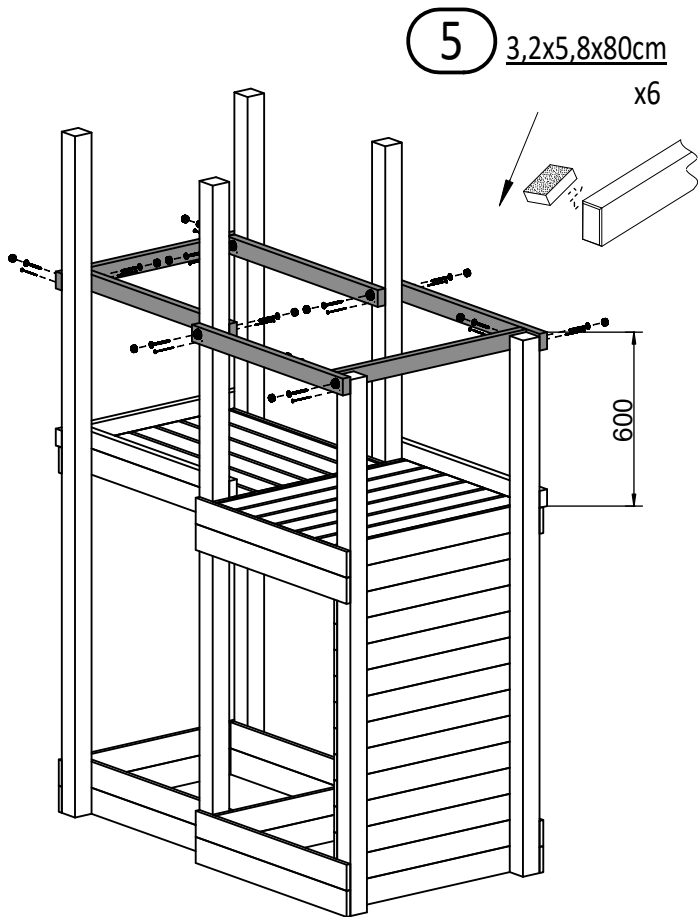

OS1 x12

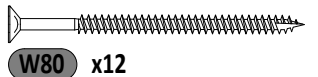

W80 x12



T80 x12

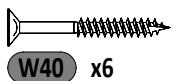
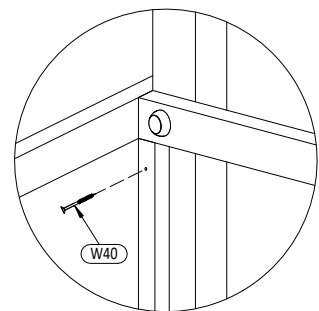
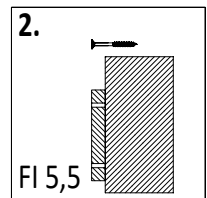
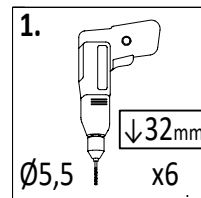
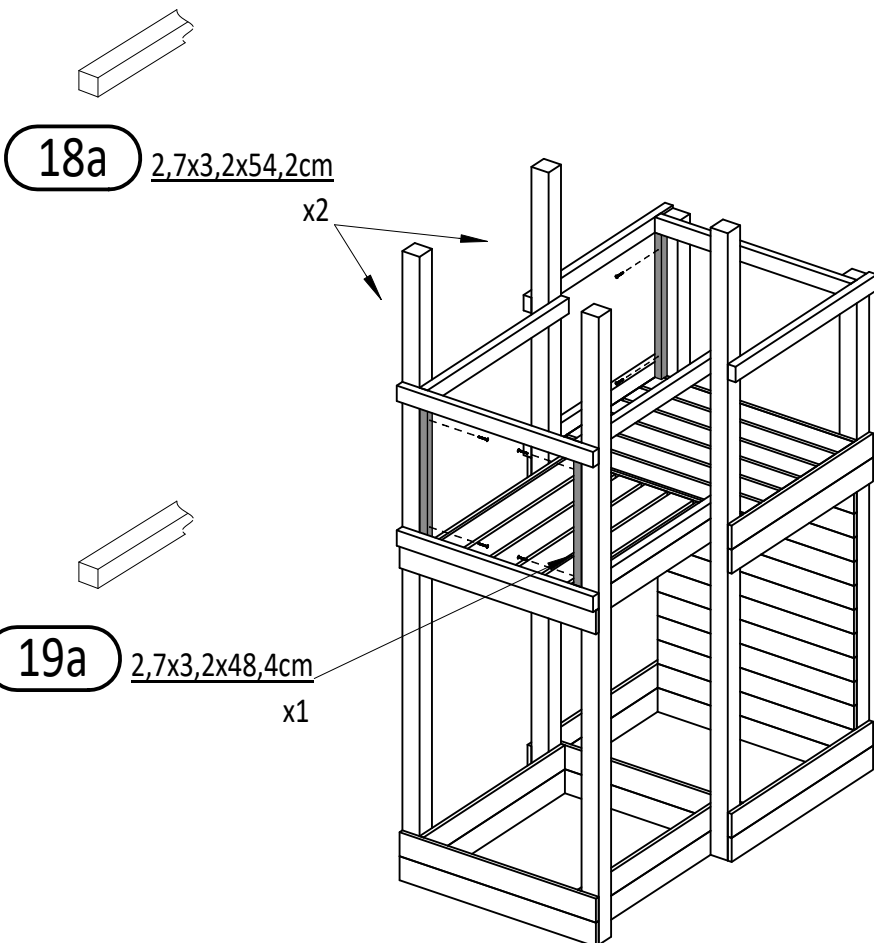

W40 x6

Zgodne z normą PN-EN 71 stosuj zalecenia producenta odnośnie odległości oraz metody mocowania poszczególnych elementów
In compliance with the standard PN-EN 71, apply guidelines of the producer in relation to distances and methods of fastening individual elements

13

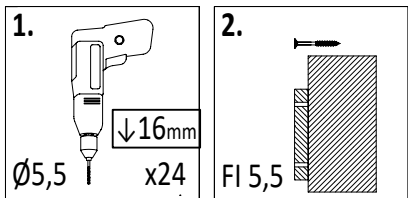

15 1,6x9,0x60cm

x6

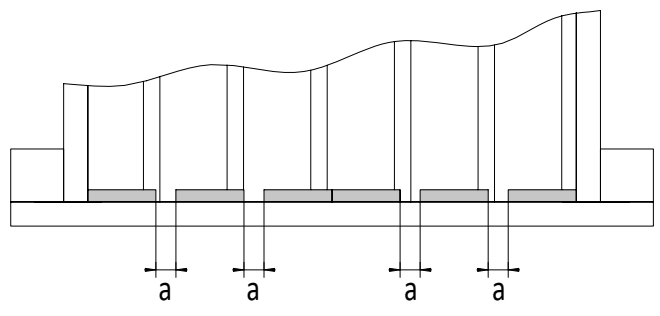
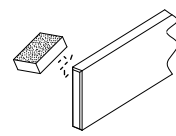

!!!min 13mm < a < !!!max 16mm

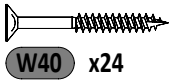
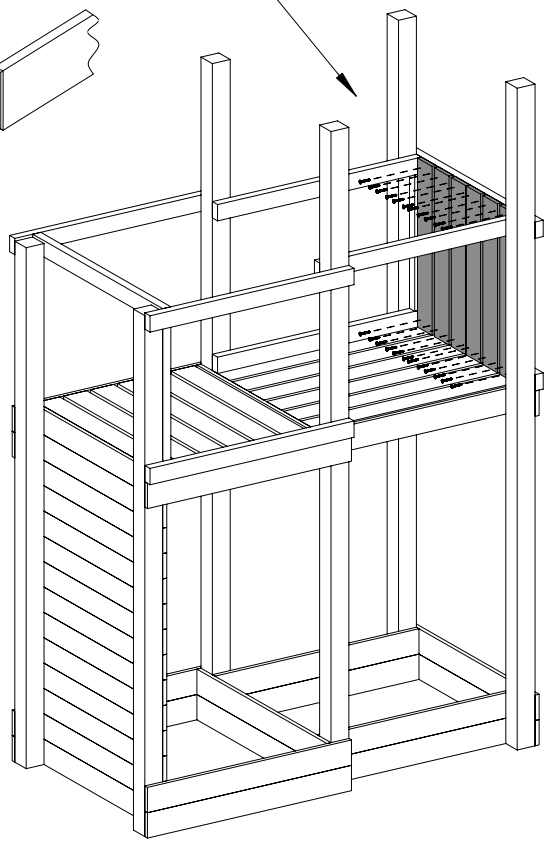

14

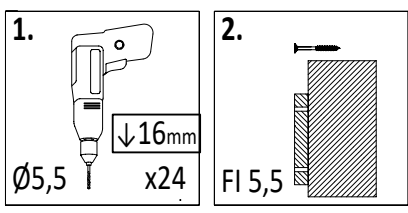

15 1,6x9,0x60cm

x6

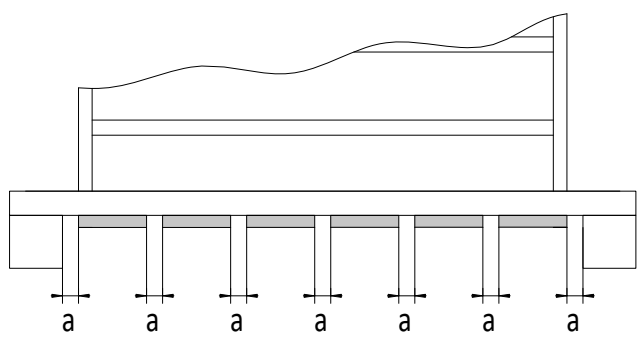
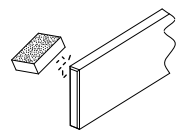

!!!min 13mm < a < !!!max 17mm

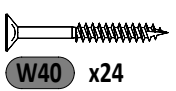
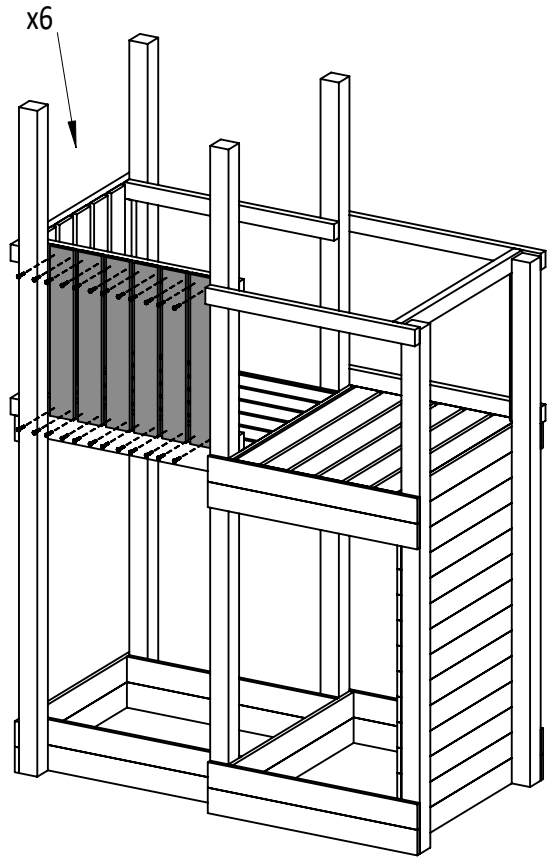

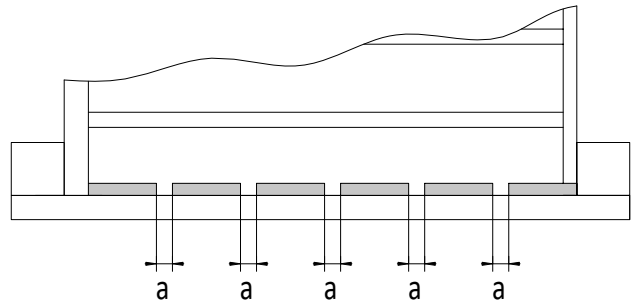
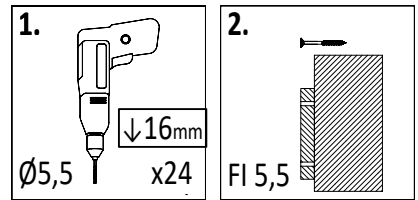
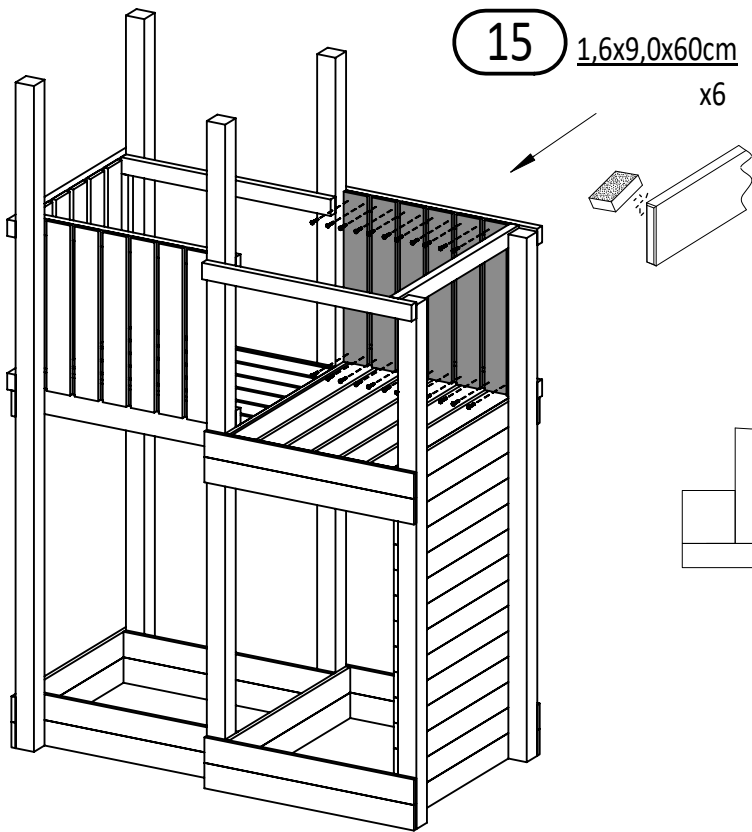

!!!min 13mm < a < !!!max 17mm

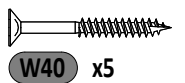
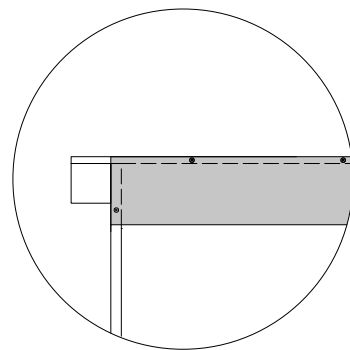
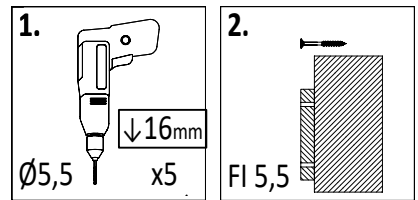
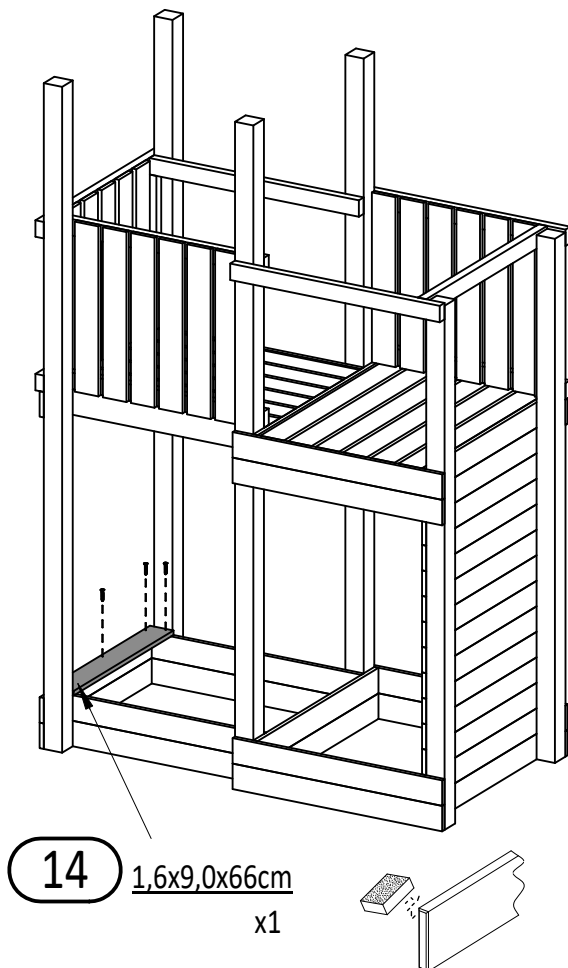
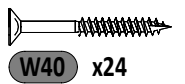

17

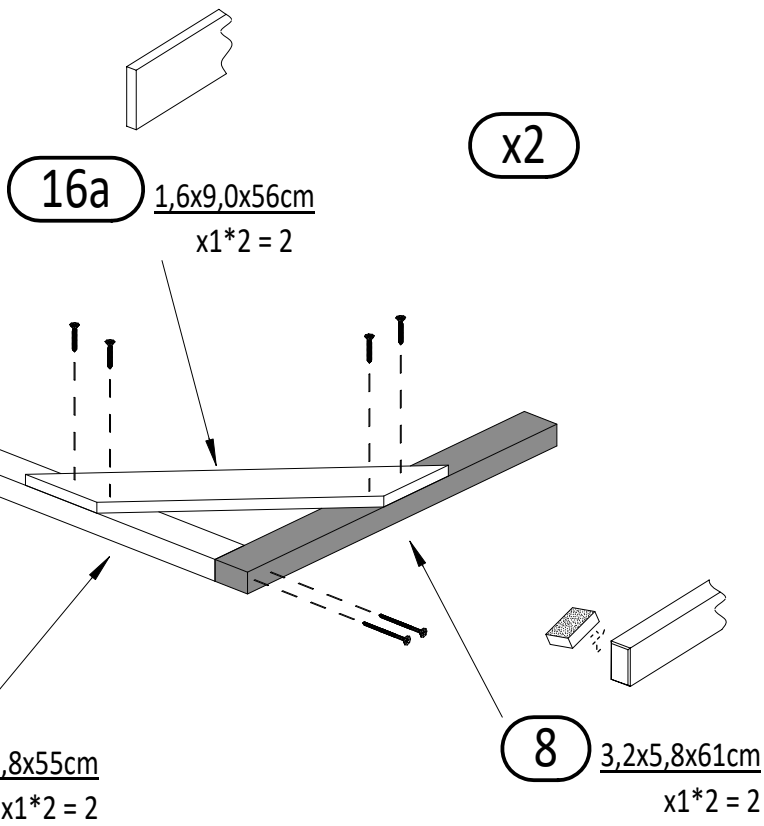
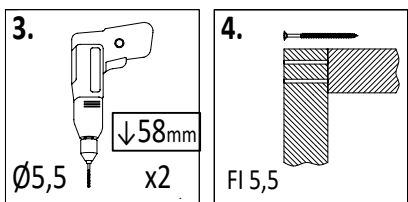
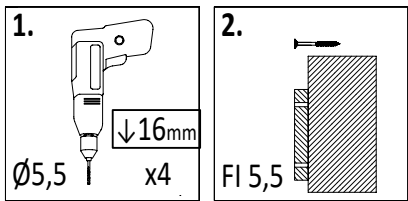

18

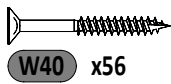
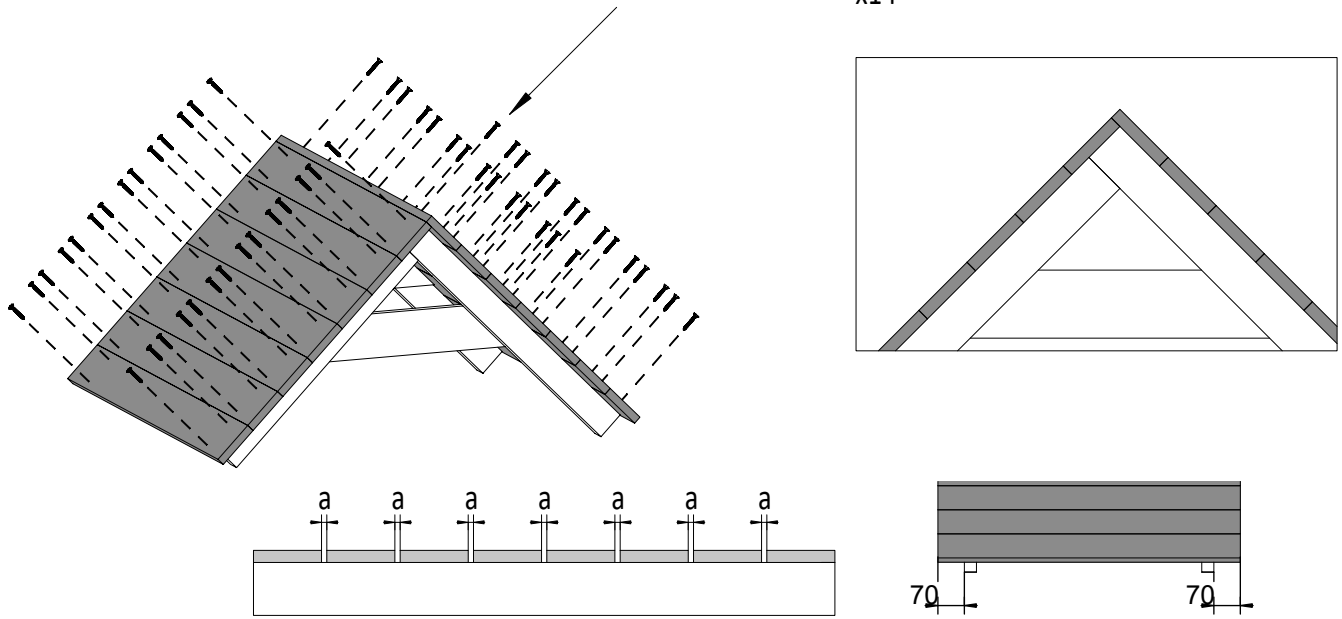
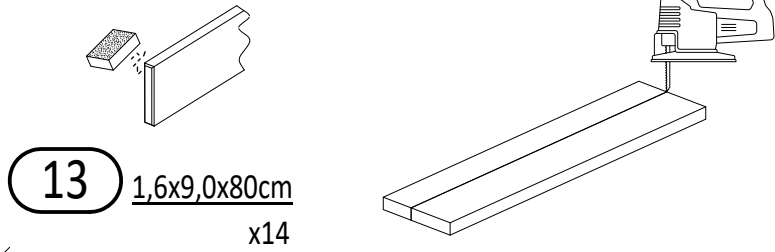
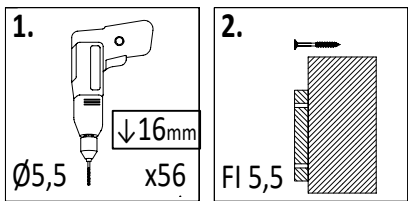

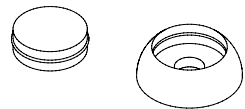
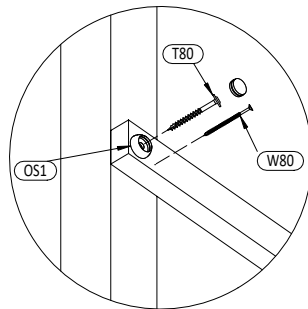
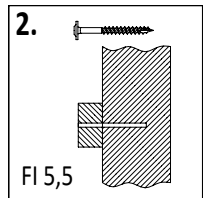
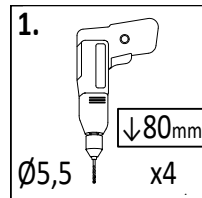
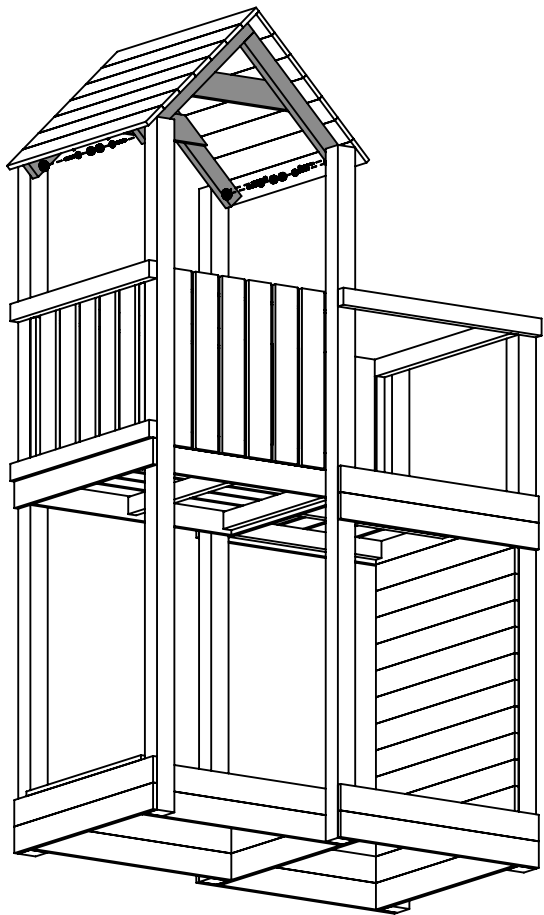

OS1 x4

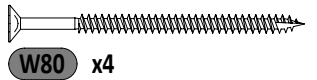

W80 x4



T80 x4

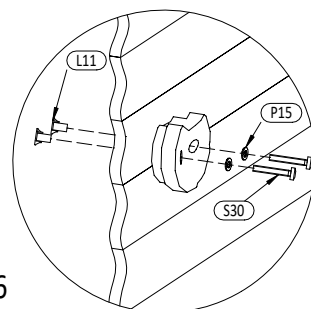
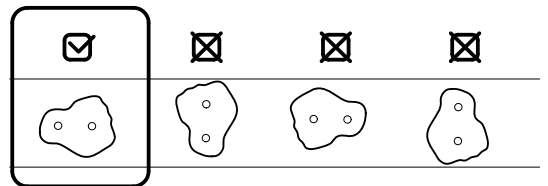
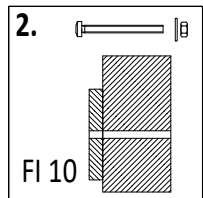
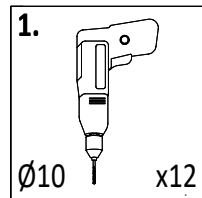
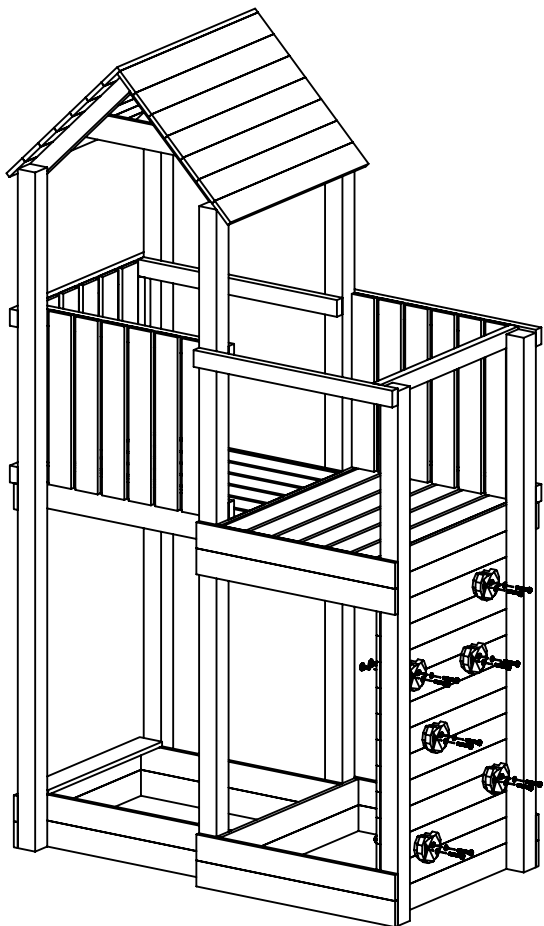

SW x6

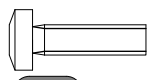

S30 x12



P15 x12

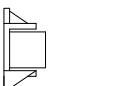

L11 x12

21

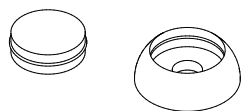
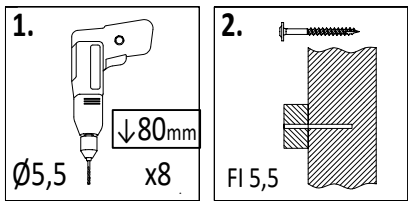

OS1 x8

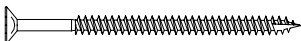

W80 x8

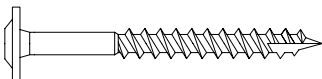

T80 x8

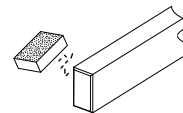
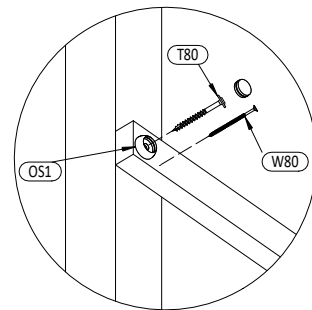
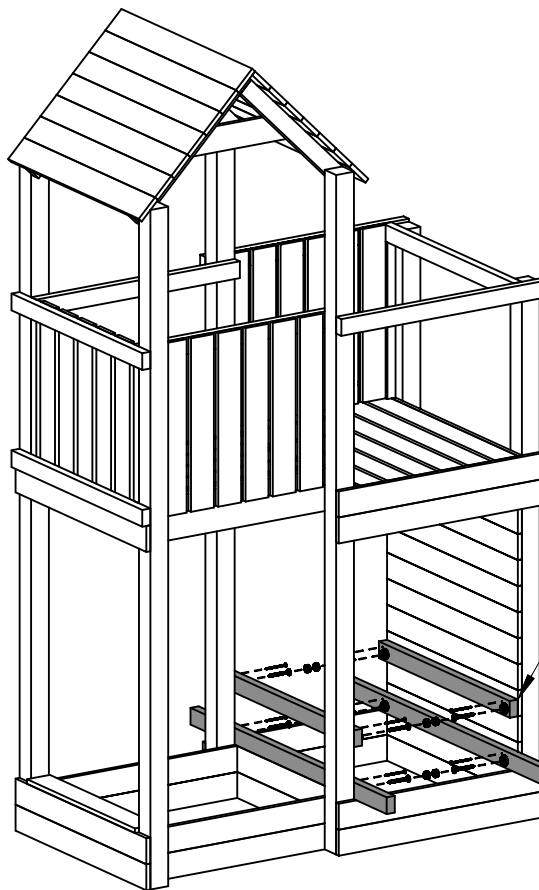

5 3,2x5,8x80cm
x2

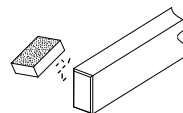

4 3,2x5,8x120cm
x2

22

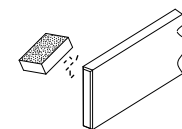
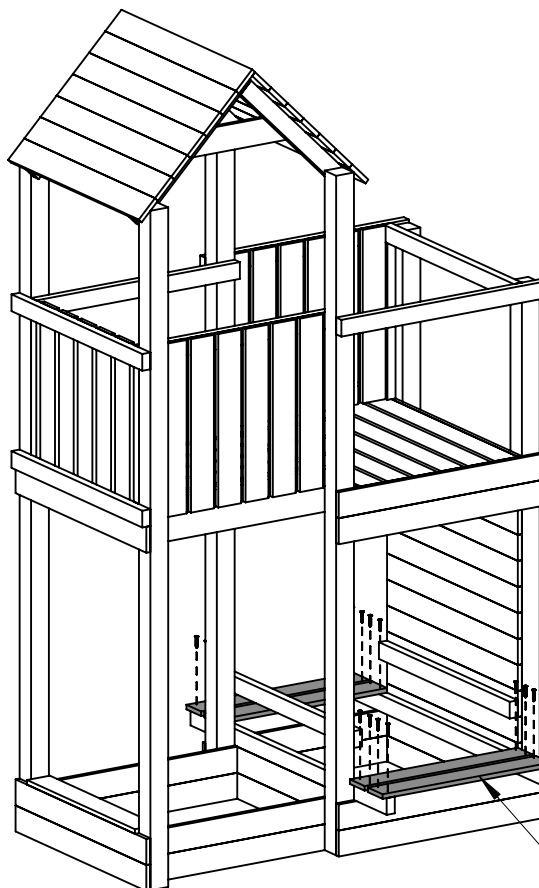
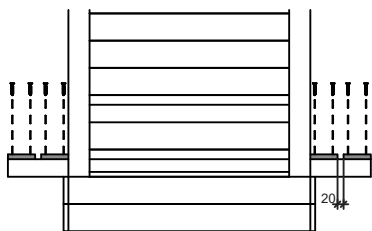
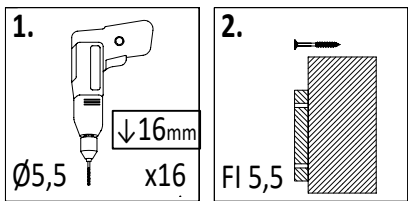

14 1,6x9,0x66cm
x4

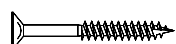

W40 x16

16 FLOPPI V2

Zgodnie z normą PN-EN 71 stosuj zalecenia producenta odnośnie odległości oraz metody mocowania poszczególnych elementów
In compliance with the standard PN-EN 71, apply guidelines of the producer in relation to distances and methods of fastening individual elements

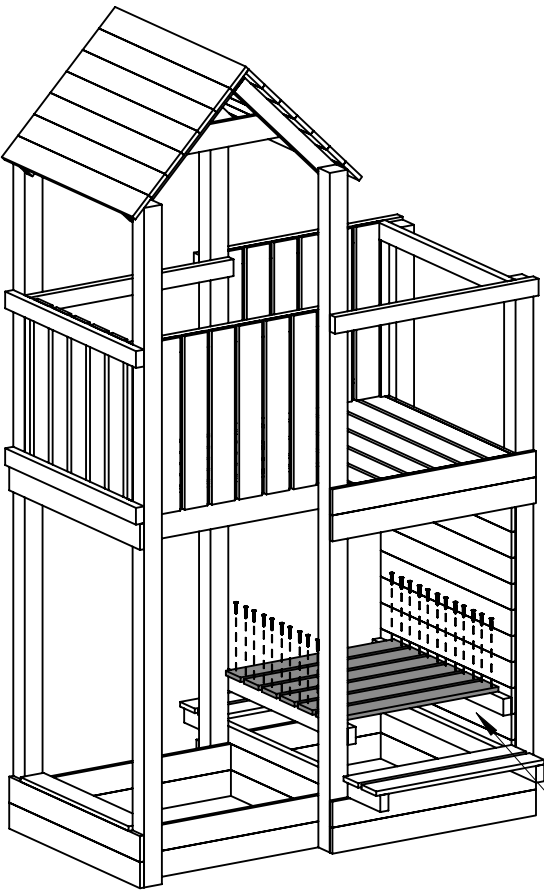
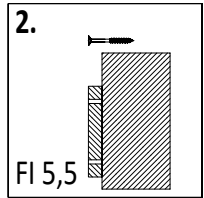
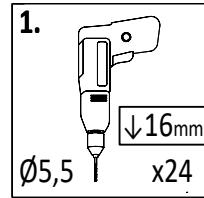

14 1,6x9,0x66cm
x6

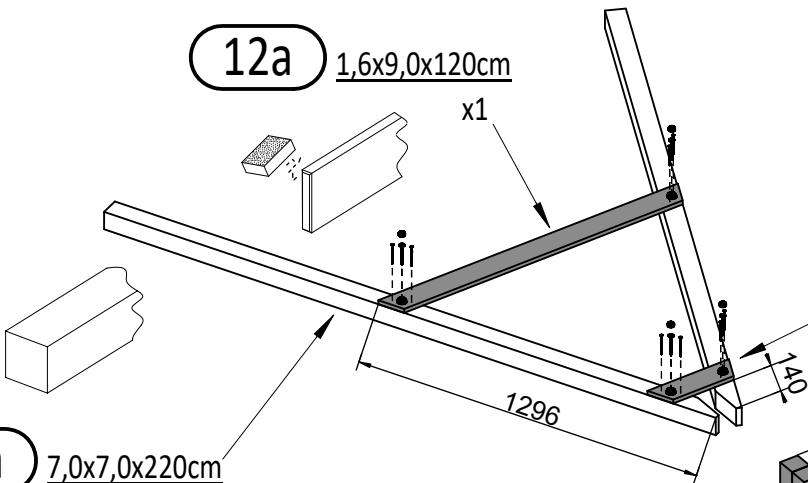
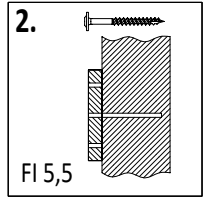
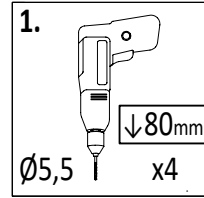
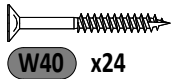
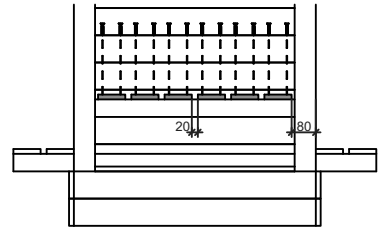

12a 1,6x9,0x120cm
x1

17a 1,6x9,0x32,6cm
x1

1a 7,0x7,0x220cm
x2

1b 7,0x7,0x220cm
x2

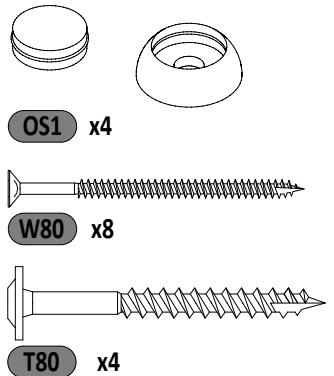
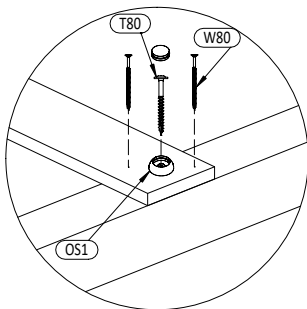
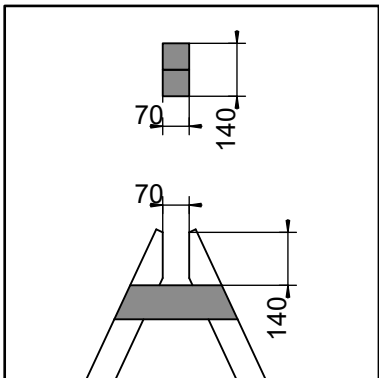

25

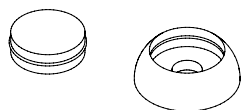
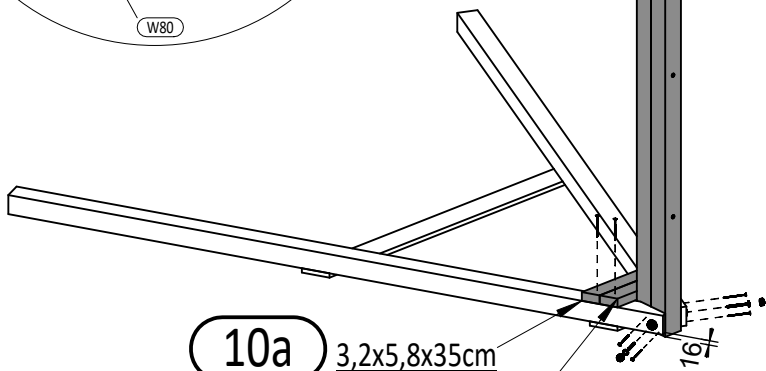
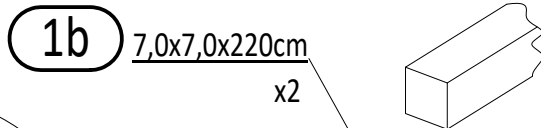
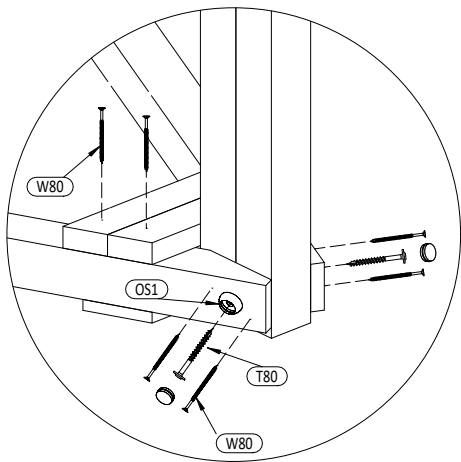
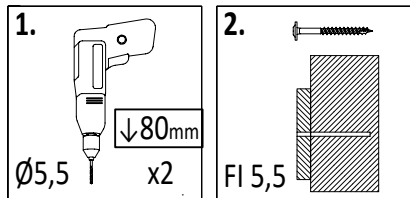

OS1 x2

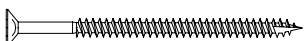

W80 x8

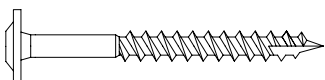

T80 x2

26

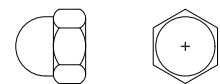
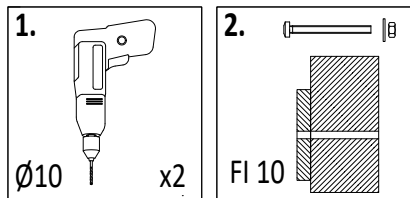

M10 x2

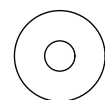

P30 x2

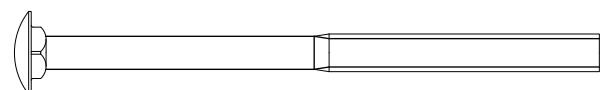

S160 x2



T60 x4

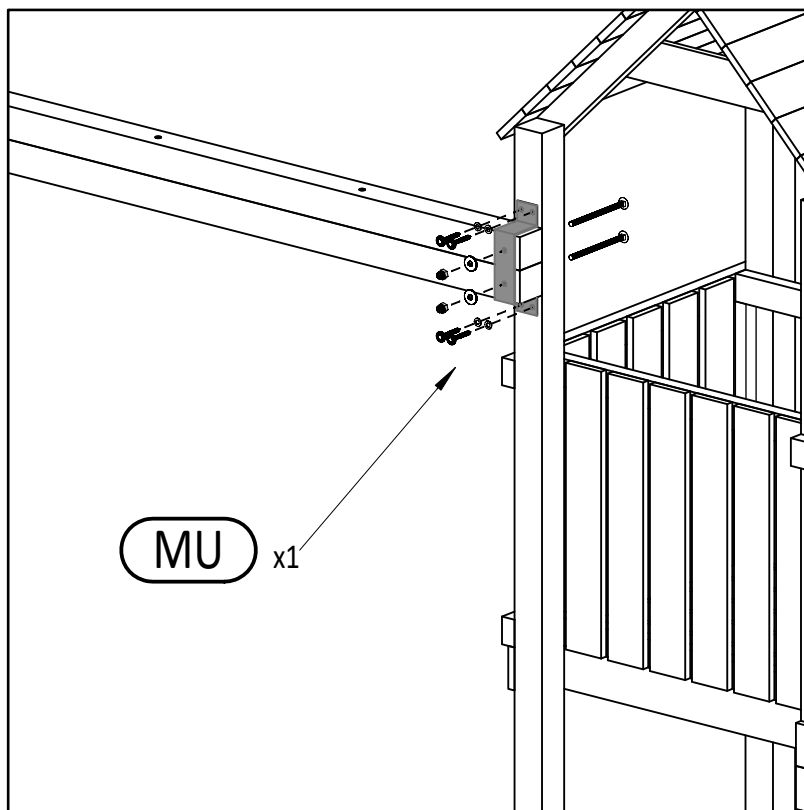
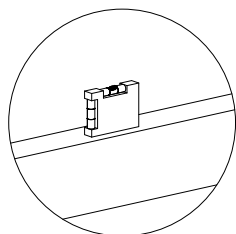

(X = X)

a a a a a a a

!!!min 2mm < a < !!!max 6mm

1. $\downarrow 16\text{mm}$
 $\varnothing 5,5$ x68

2. FI 5,5

1. $\downarrow 32\text{mm}$
 $\varnothing 5,5$ x10

2. FI 5,5

6 3,2x5,8x66cm
x5

3a 3,5x9,0x170cm
x2

14a 1,6x9,0x66cm
x1

14 1,6x9,0x66cm
x15

W40 x68

W80 x10

1. $\downarrow 80\text{mm}$
 $\varnothing 5,5$ x2

2. FI 5,5

W80 x2

T80 x2

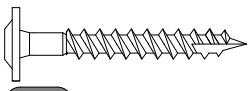
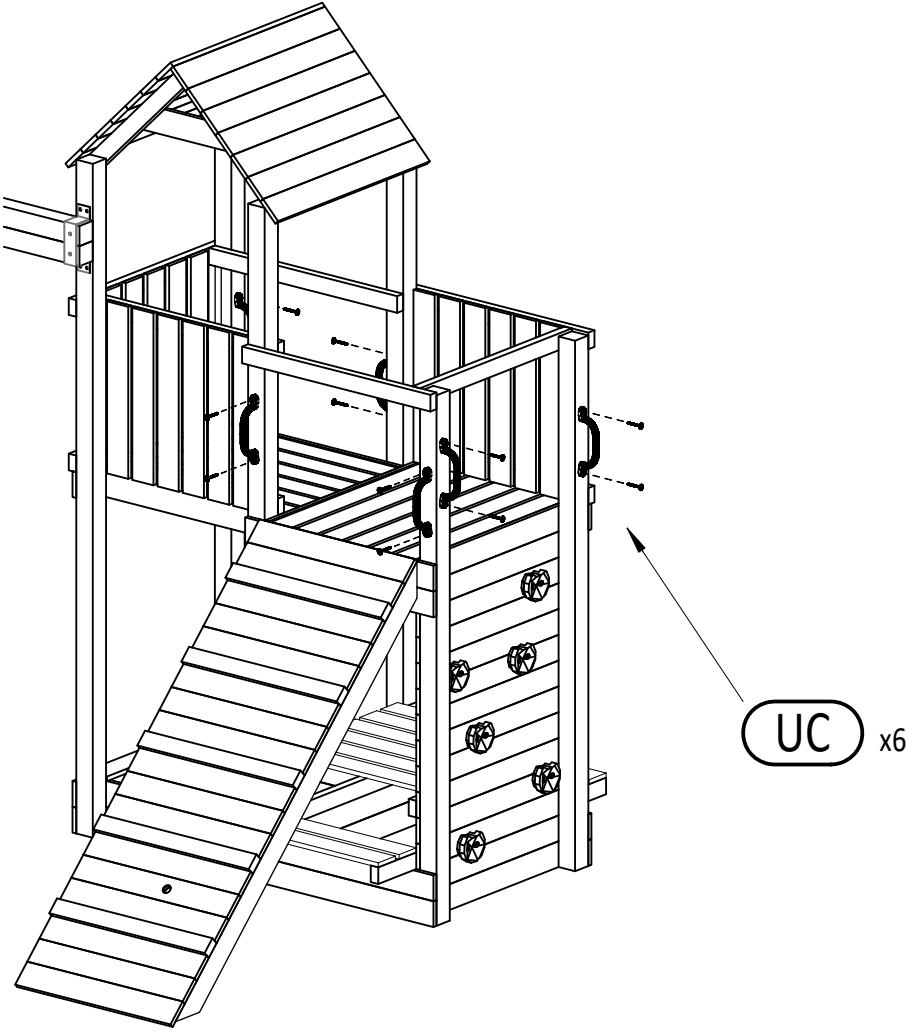
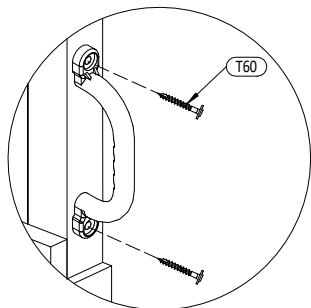

T60 x12

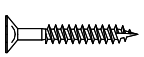
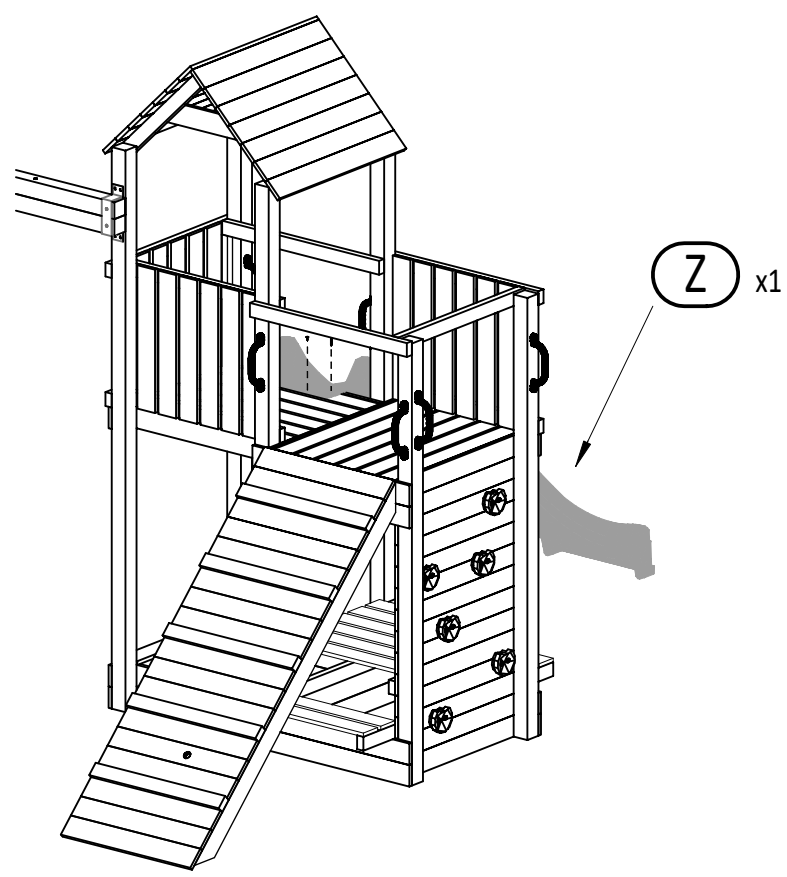
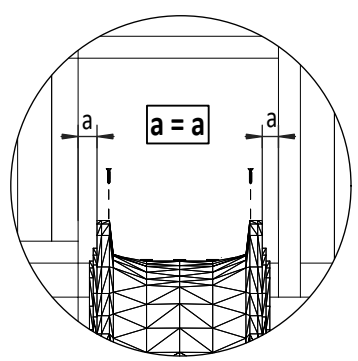

W30 x2

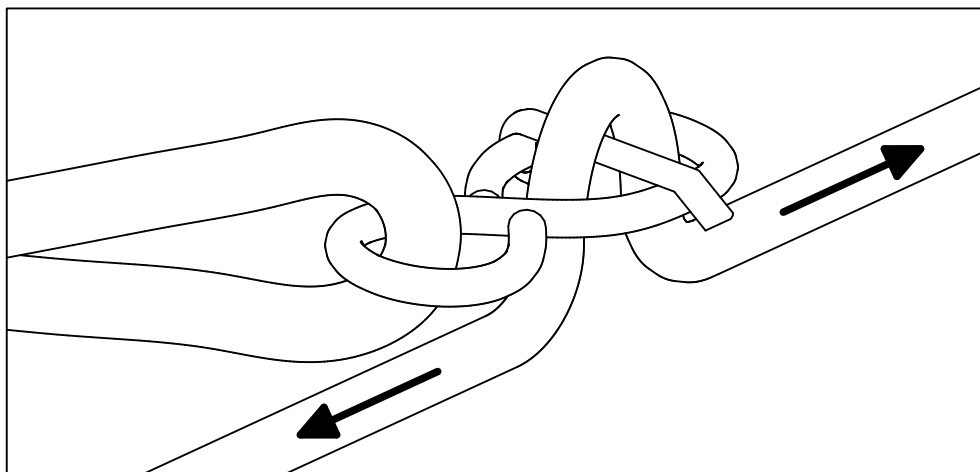
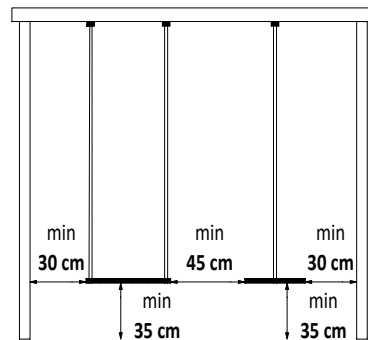
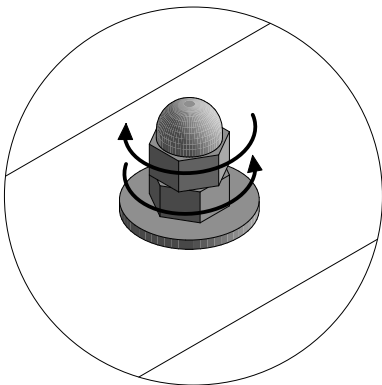
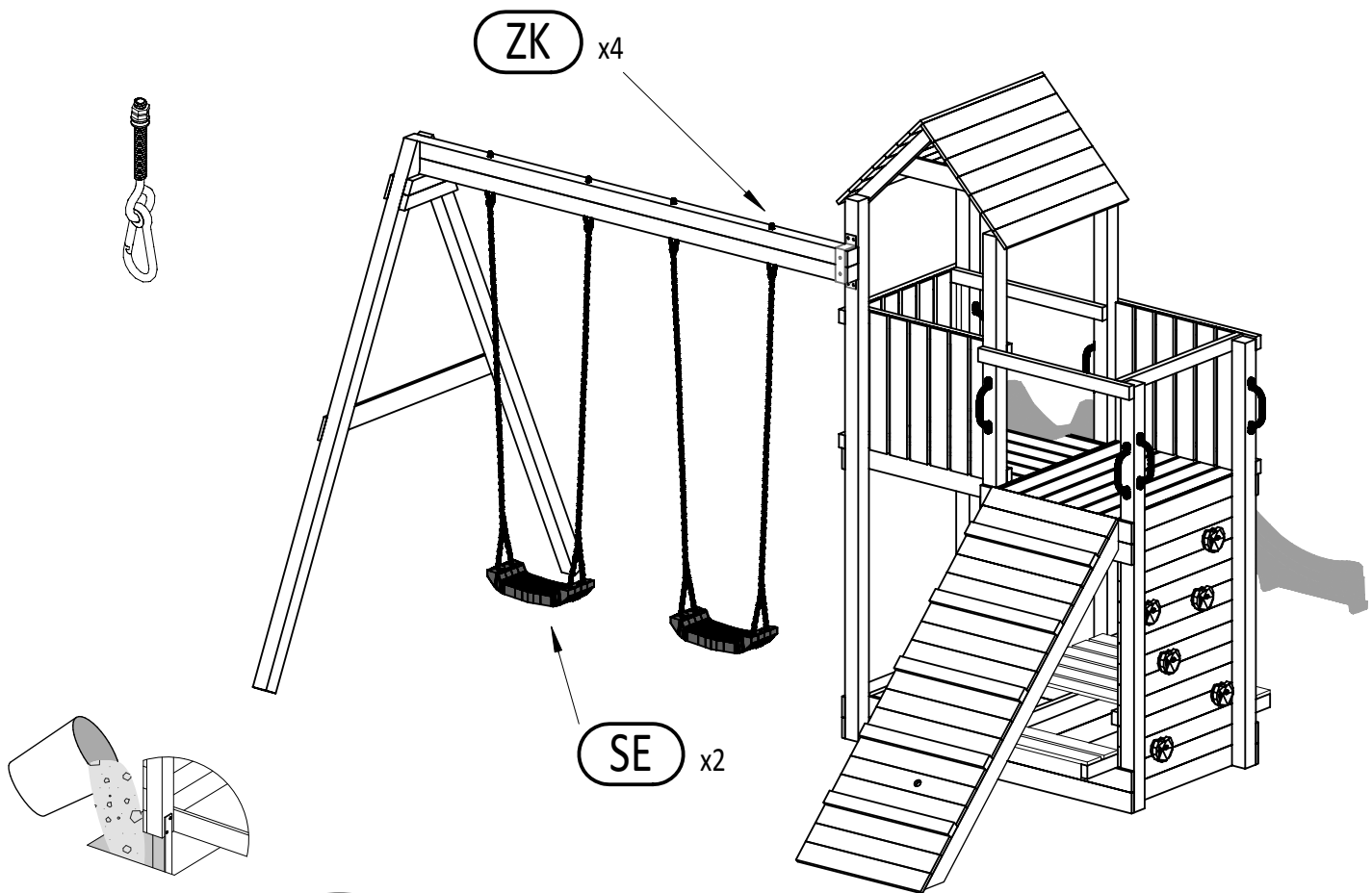

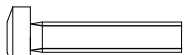
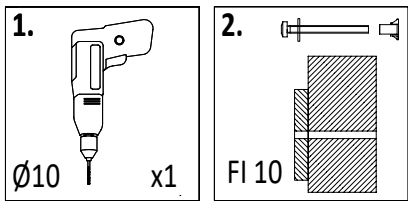

S40 x1

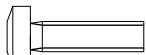

S30 x1



P17 x3



L11 x1



NS x1

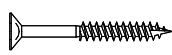

W40 x2



W20 x2

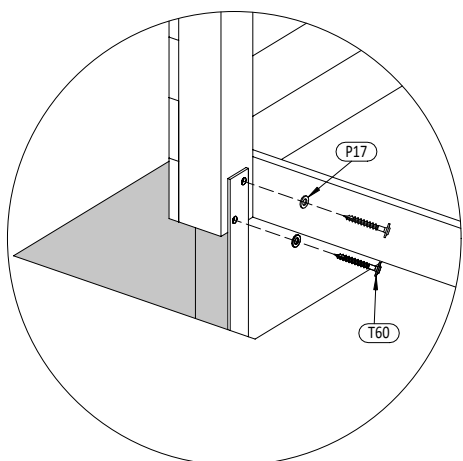
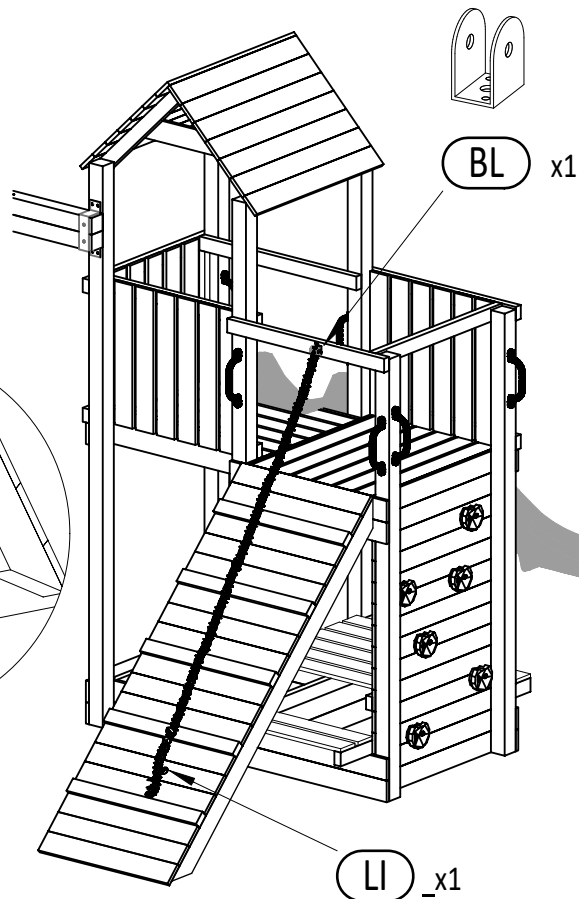
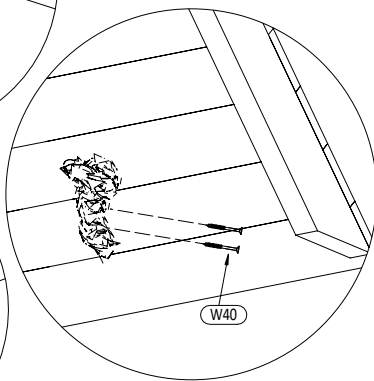
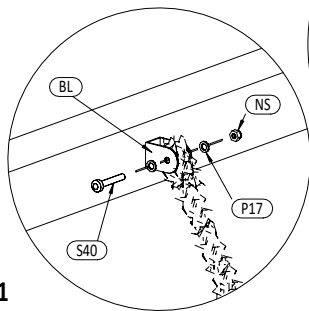
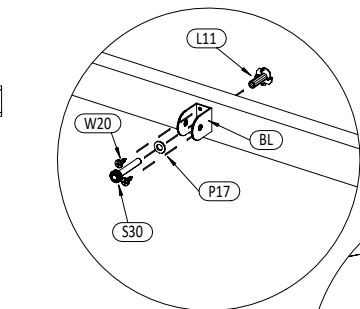

P17 x12

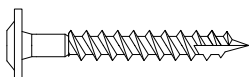

T60 x12

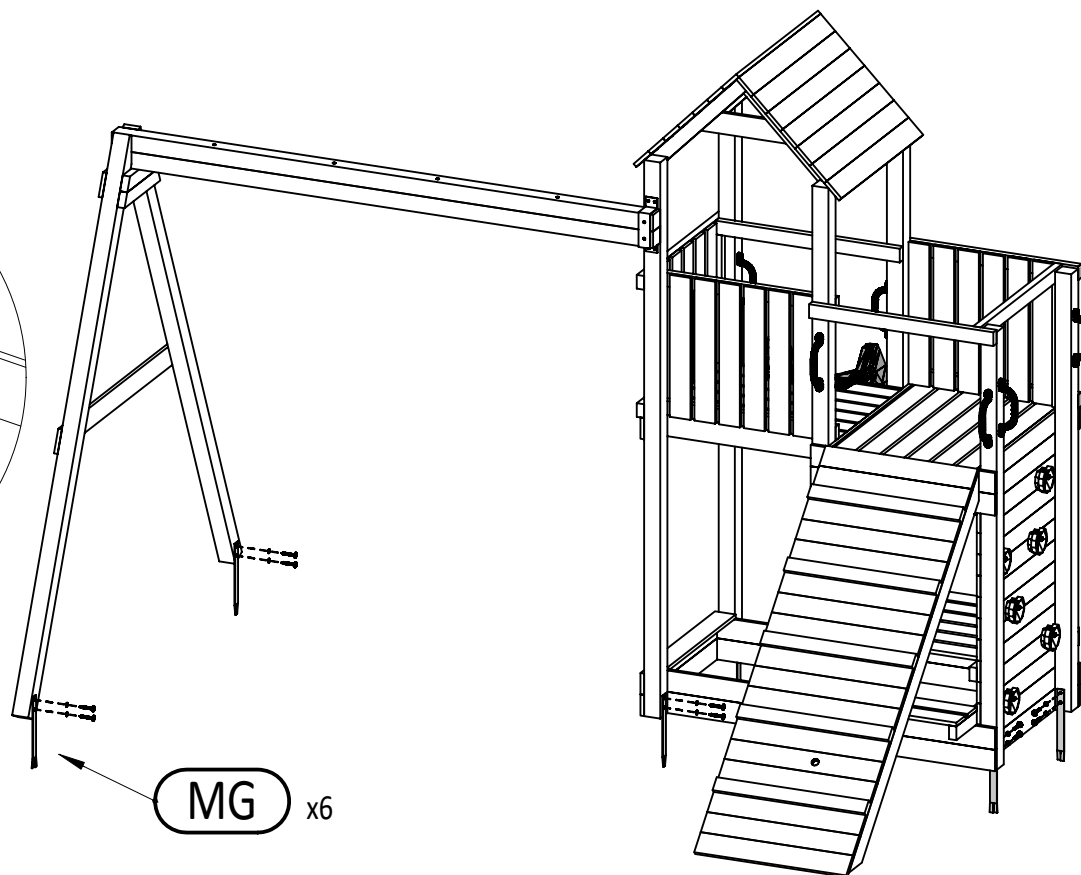

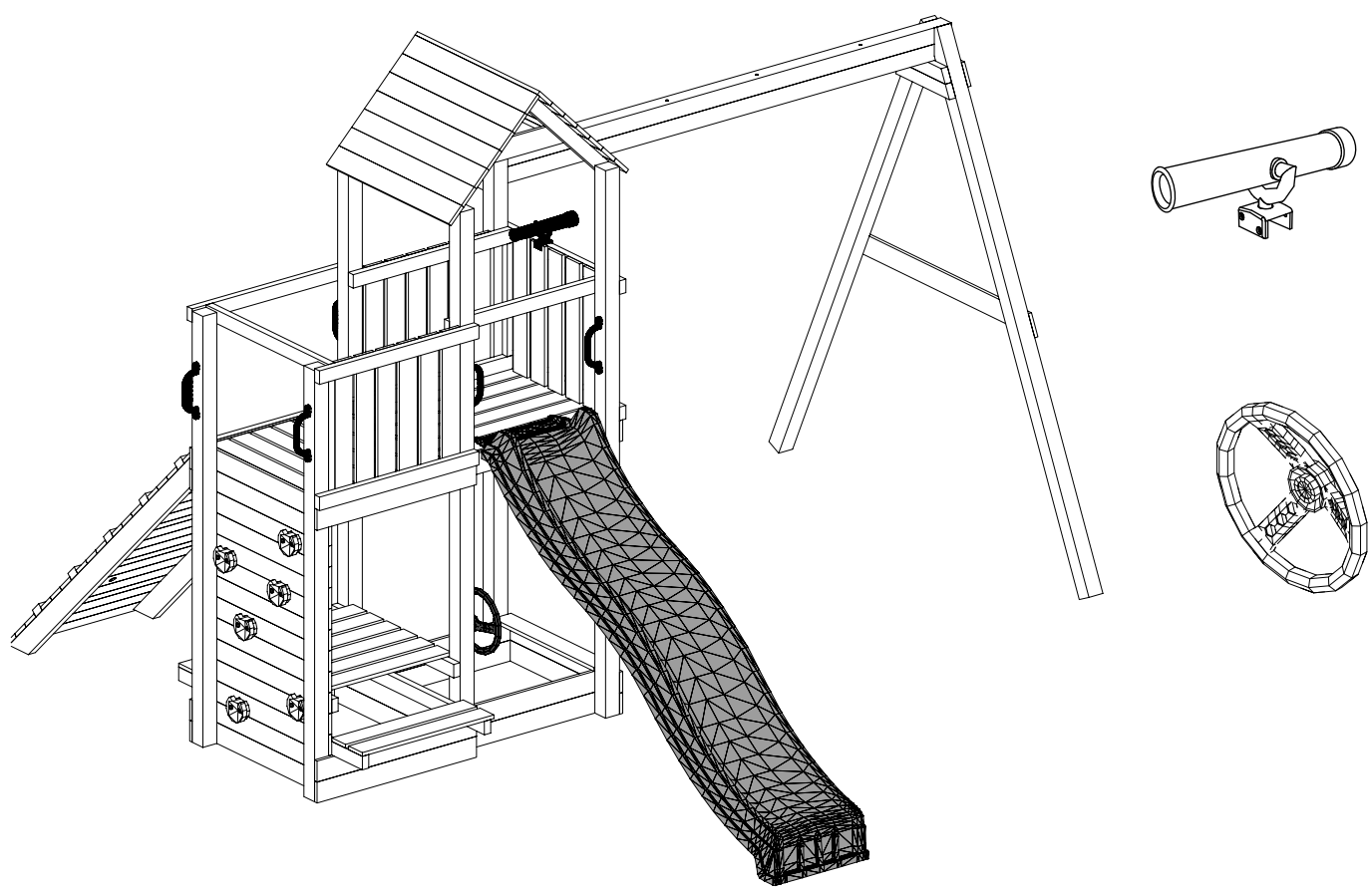
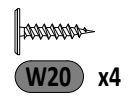
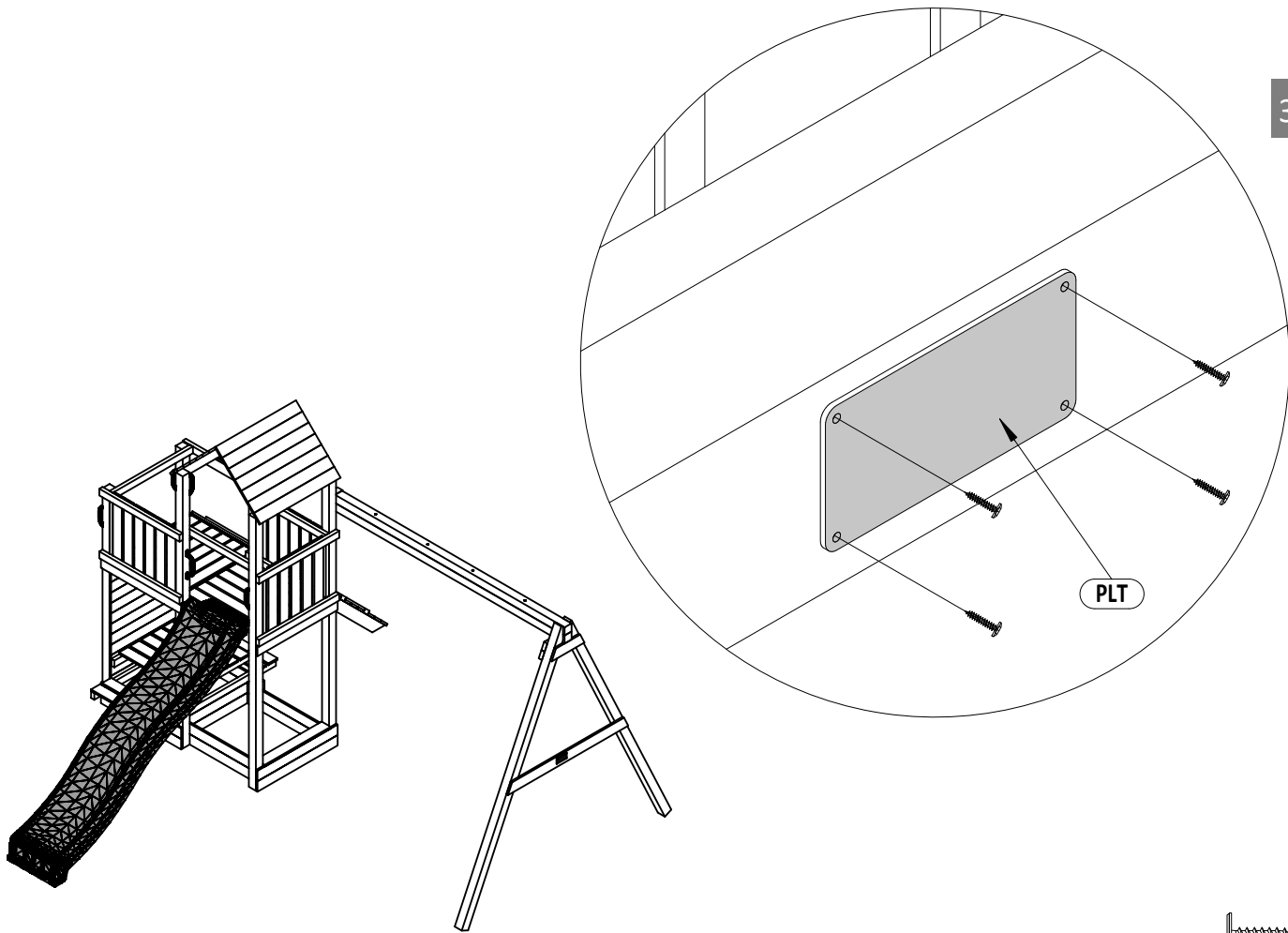

Zgodnie z normą PN-EN 71 stosuj zalecenia producenta odnośnie odległości oraz metody mocowania poszczególnych elementów
 In compliance with the standard PN-EN 71, apply guidelines of the producer in relation to distances and methods of fastening individual elements