

PLAYGROUND SPIELPLATZ

PLAC ZABAW AIRE DE JEUX

(374 x 136 x h293cm)

003_00555_27042021

JOY

INSTALLATION INSTRUCTIONS
MONTAGEANLEITUNG

INSTRUKCJA MONTAŻU
GUIDE D'INSTALLATION

Warranty period - 2 years from purchase date

Garantiezeit - 2 Jahre ab Kaufdatum

Okres gwarancji - 2 lata od momentu zakupu towaru

Période de garantie - 2 ans à compter de l'achat

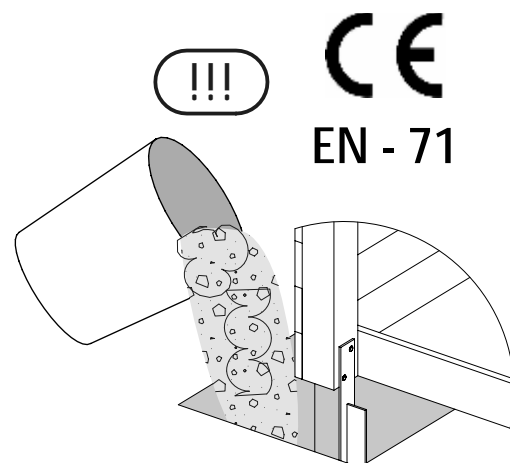
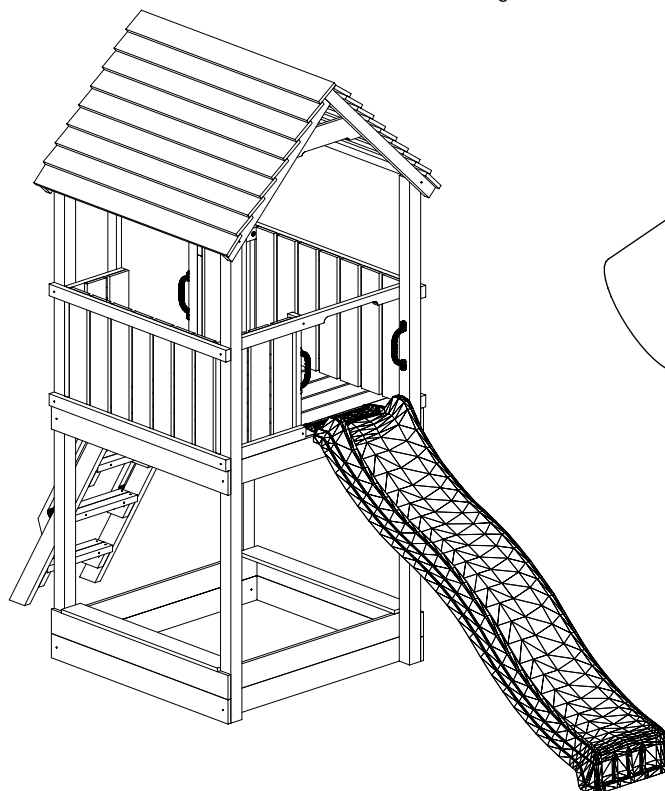

WARNINGS!

Only for home use.

Dedicated for external use only.

Not suitable for children under 3 years old.

Risk of falling down and/or hitting.

Maximum user weight is up to 50 kg.

Maximum number of users staying on the playground at the same time: 5.

OSTRZEŻENIA!

Tylko do użytku domowego.

Przeznaczony do użytku na zewnątrz.

Nie przeznaczony dla dzieci poniżej 3 roku życia.

Niebezpieczeństwo upadku i/lub uderzenia.

Maksymalna waga użytkownika to 50 kg.

Maksymalna liczba użytkowników przebywających na placu zabaw w tym samym czasie: 5.

ACHTUNG!

Nur für den privaten, häuslichen Bereich.

Ausschließlich für die Verwendung im Freien.

Nicht geeignet für Kinder unter 3 Jahren.

Stolper- und / oder Sturzgefahr

Höchstgewicht pro Einzelkind beträgt 50 kg

Der Aufenthalt auf diesem Spielturm ist max. : 5.

Kindern gleichzeitig erlaubt.

AVERTISSEMENT!

Aire exclusivement destinée à un usage privé.

Aire exclusivement destinée à un usage en extérieur.

Prévue pour les enfants de plus de 3 ans.

Danger de chute ou de choc.

Poids maximal d'un utilisateur : 50 kg.

Nombre maximal d'utilisateurs présents en même temps sur la même aire de jeux: 5.

W80 x127

+1 Gratis



W40 x217

+2 Gratis



W30 x2

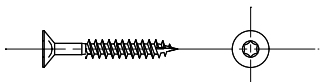

W20 x12

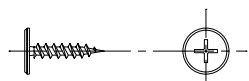

T80 x45

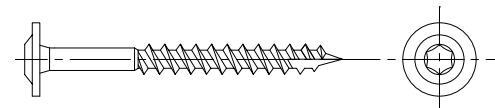

T60 x34

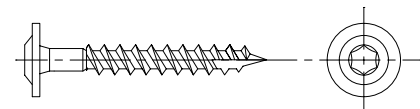

S50 x4

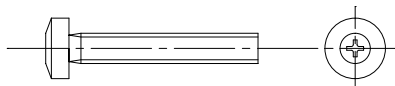

L11 x4

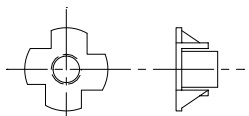

P17 x12

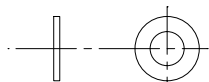

OS1 x37

+2 Gratis

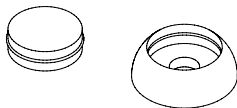

Ø5,5
01372
x1

Ø10
00188
x1



PH3
00068
x1

PZ2
00241
x1

TX25
00190
x1

TX30
00316
x1

TX40
00242
x1

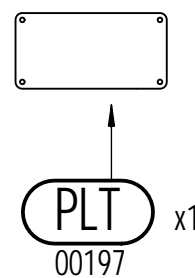
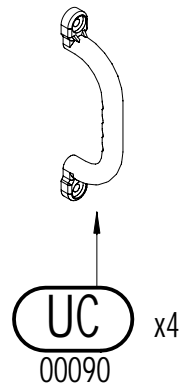
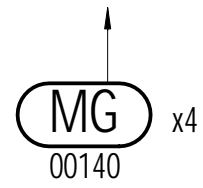
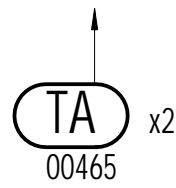
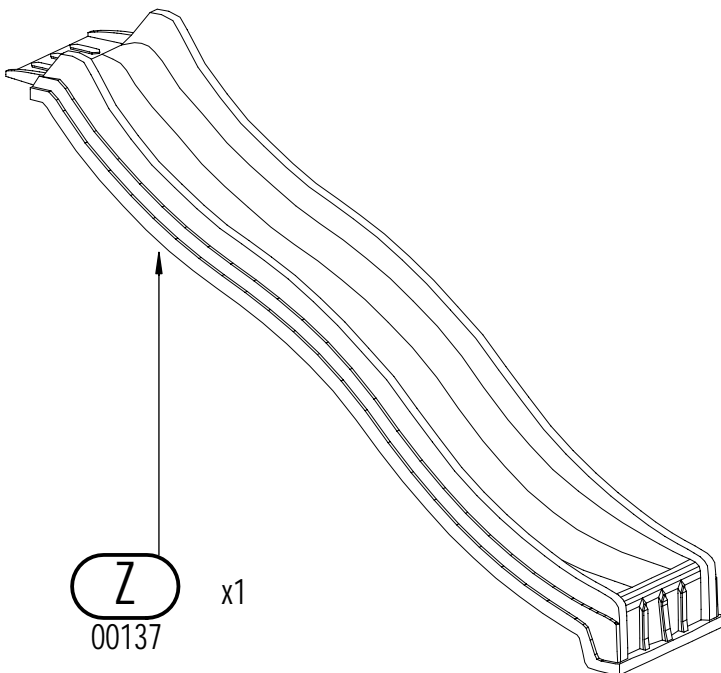
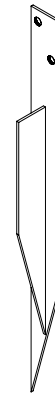
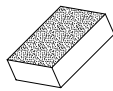
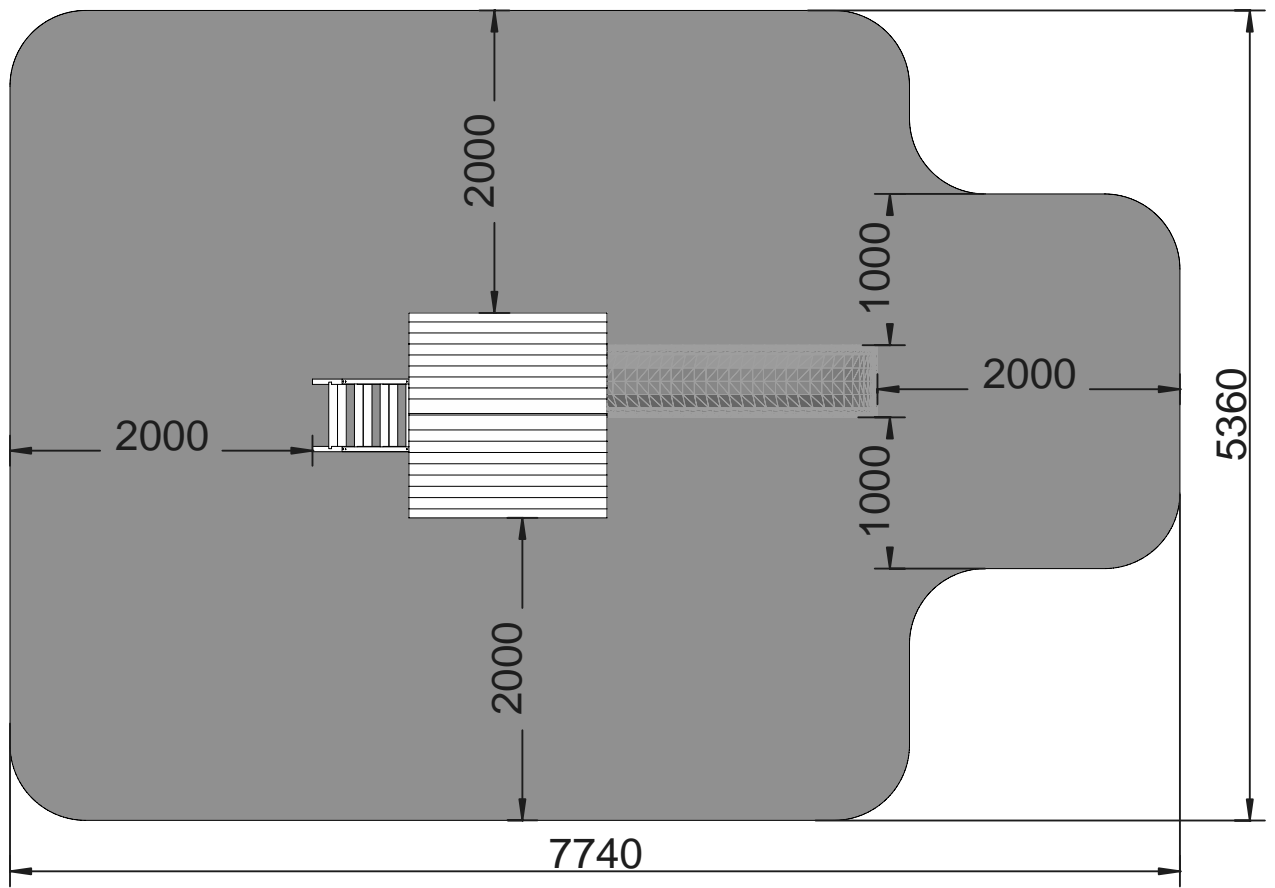

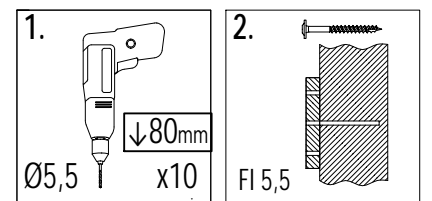
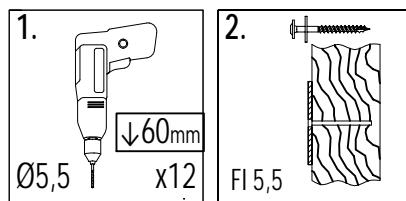
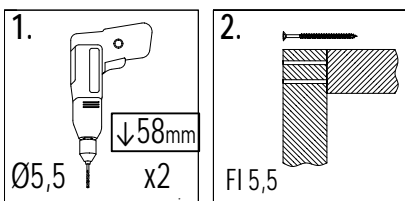
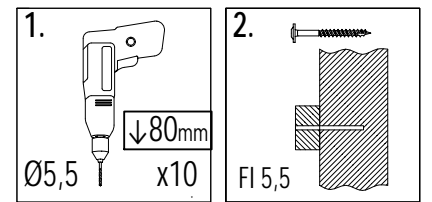
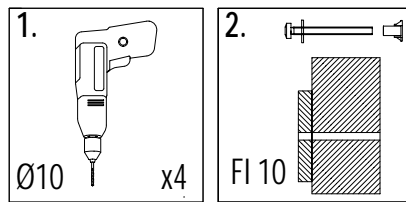
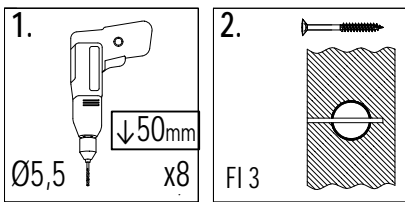
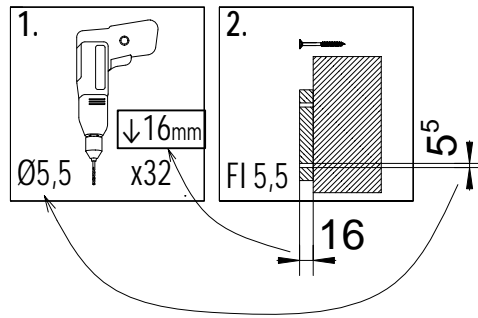
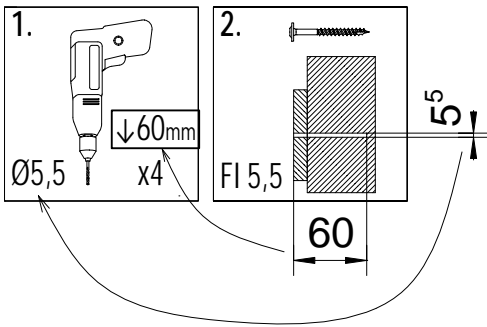
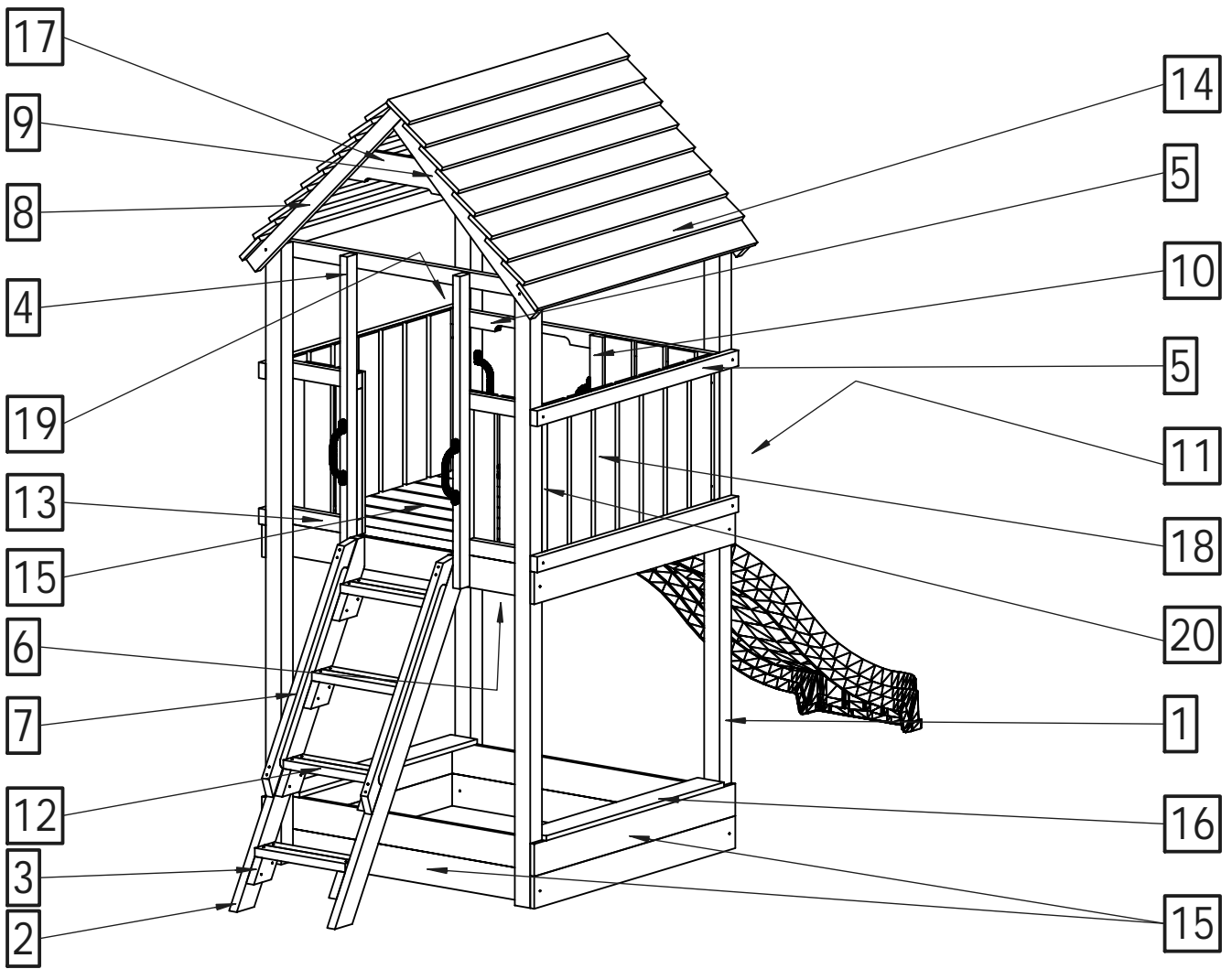

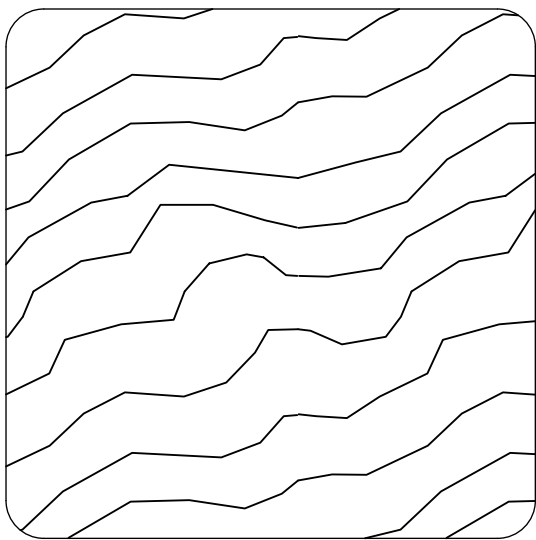

7,0 x 7,0 cm

Lp.	Kod	Wymiary [mm]	szt.
1	04451	70x70x2300mm	4

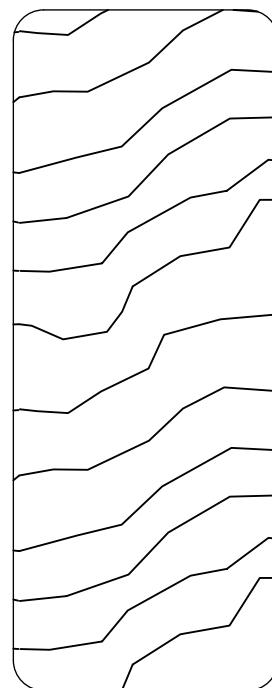

3,5 x 9,0 cm

Lp.	Kod	Wymiary [mm]	szt.
2a	06686	35x90x1465mm	2
3a	00730	35x90x156mm	8

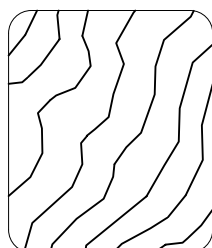

2,7 x 3,2 cm

Lp.	Kod	Wymiary [mm]	szt.
19a	04471	27x32x542mm	1
20a	04476	27x32x484mm	5

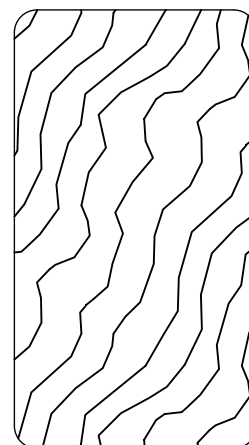

3,2 x 5,8 cm

Lp.	Kod	Wymiary [mm]	szt.
4a	02833	32x58x1200mm	4
4b	00818	32x58x1200mm	1
4c	00530	32x58x1200mm	1
5	00304	32x58x1160mm	2
6	06689	32x58x1024mm	3
7a	00207	32x58x1000mm	2
8a	02835	32x58x940mm	2
9a	02846	32x58x880mm	2
10	00296	32x58x600mm	1
11a	00108	32x58x540mm	1
12a	00350	32x58x410mm	4
12b	00340	32x58x410mm	4
13a	02793	32x58x360mm	4

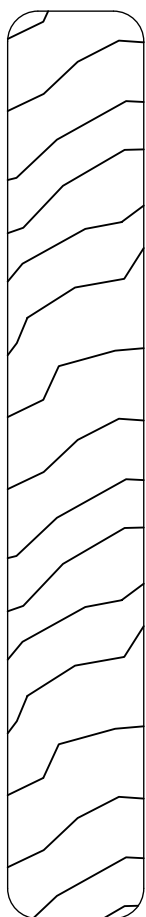

1,8 x 12,0 cm

Lp.	Kod	Wymiary [mm]	szt.
14	00144	18x120x1310mm	18
15	00142	18x120x1200mm	12
15a	00846	18x120x1200mm	8
16	00174	18x120x1060mm	2
17a	06692	18x120x620mm	2
18	00495	18x120x600mm	21

1

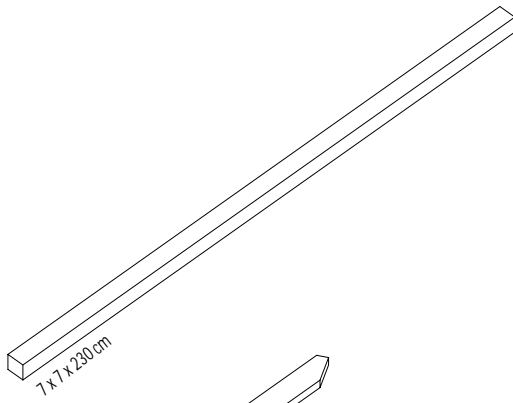

2a

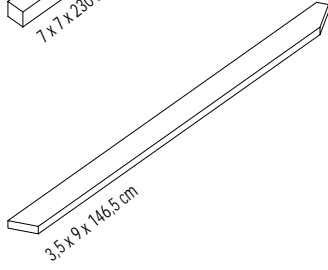

3a



4a

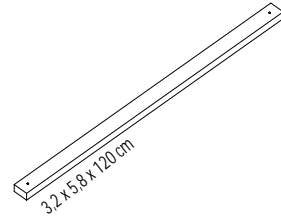

4b

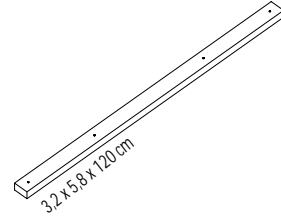

4c

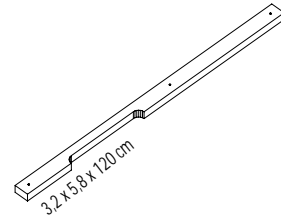

5

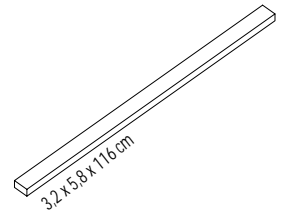

6

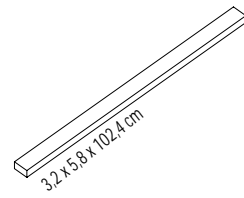

7a

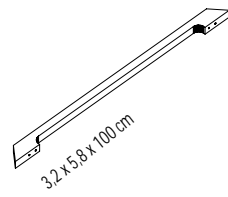

8a

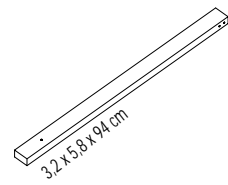

9a

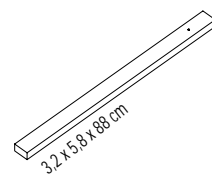

10

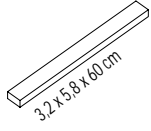

3.2 x 5.8 x 60 cm

14

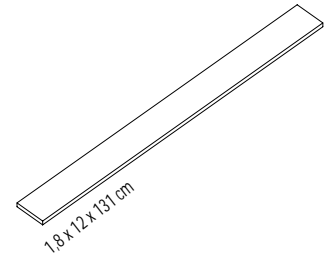

1.8 x 12 x 131 cm

11a

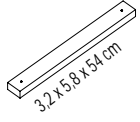

3.2 x 5.8 x 54 cm

15

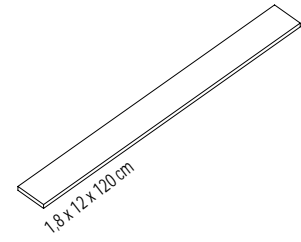

1.8 x 12 x 120 cm

12a

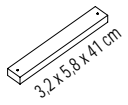

3.2 x 5.8 x 41 cm

15a

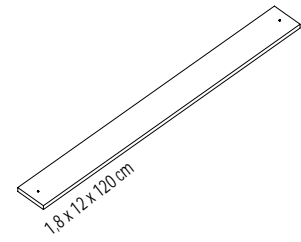

1.8 x 12 x 120 cm

12b

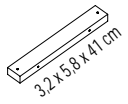

3.2 x 5.8 x 41 cm

16

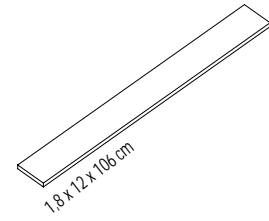

1.8 x 12 x 106 cm

13a

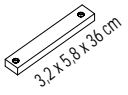

3.2 x 5.8 x 36 cm

17a

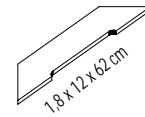

1.8 x 12 x 62 cm

18

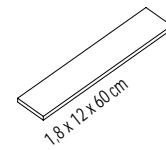

1.8 x 12 x 60 cm

19a

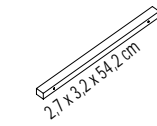

2.1 x 3.2 x 54.2 cm

20a

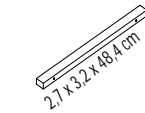

2.1 x 3.2 x 48.4 cm

01

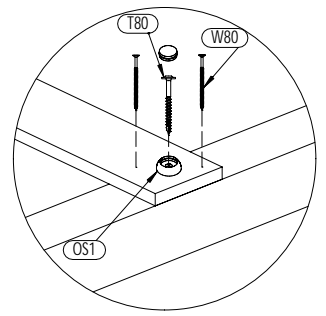
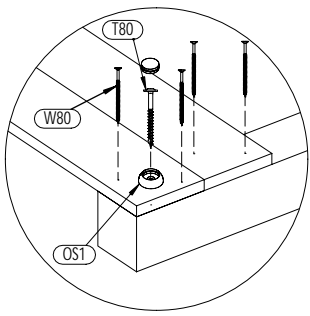
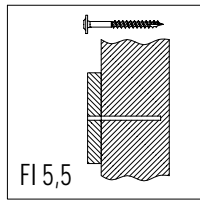
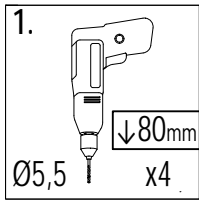

!!! x2

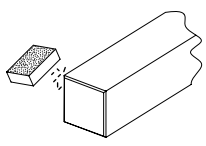

15 1,8x12,0x120cm x1

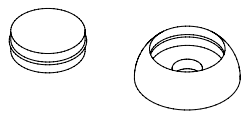

OS1 x4*2 = 8

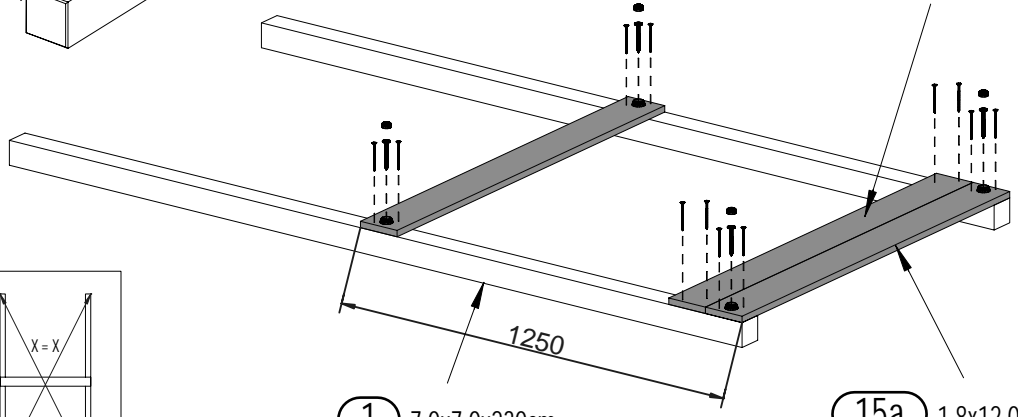
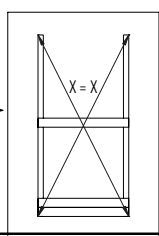
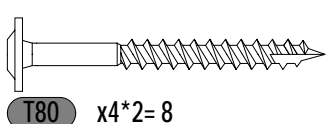
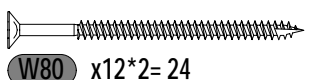

1 7,0x7,0x230cm x2

15a 1,8x12,0x120cm x2

02

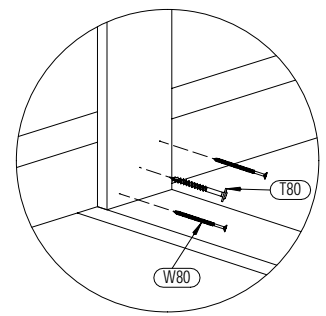
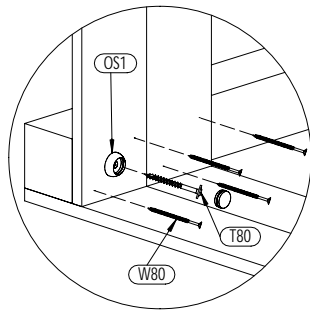
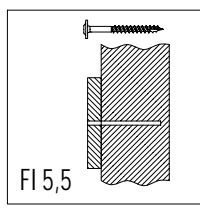
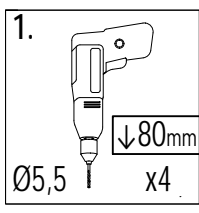

15a 1,8x12,0x120cm x4

15 1,8x12,0x120cm x2

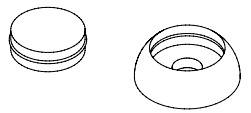

OS1 x2

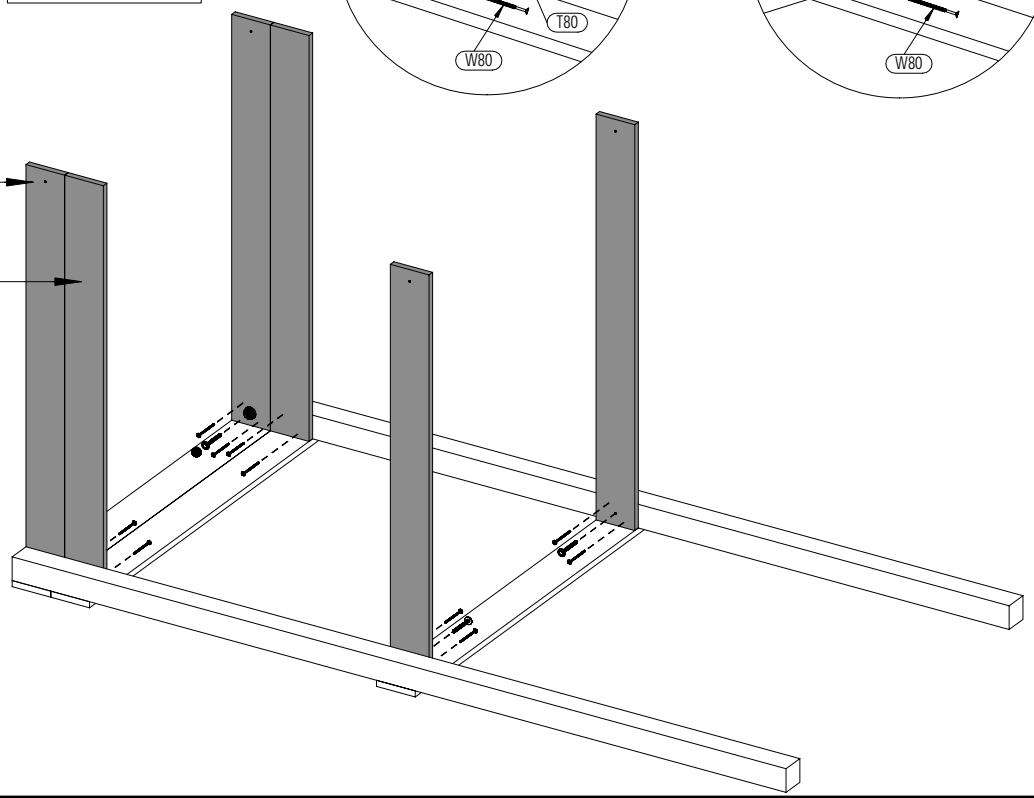
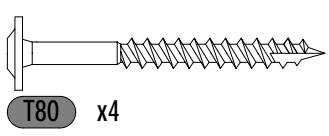
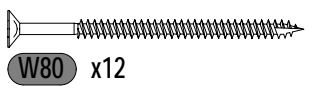

8

JOY

Zgodnie z normą PN-EN 71 stosuj zalecenia producenta odnośnie odległości oraz metody mocowania poszczególnych elementów
 In compliance with the standard PN-EN 71, apply guidelines of the producer in relation to distances and methods of fastening individual elements

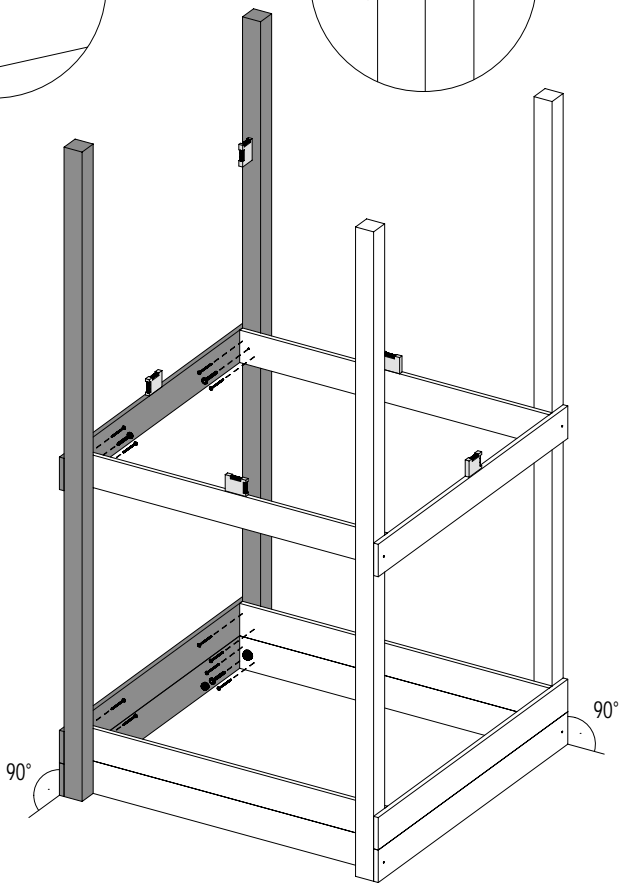
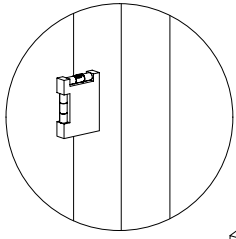
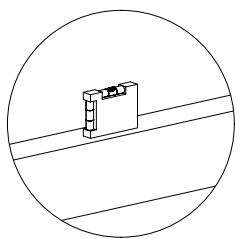

1. $\downarrow 80\text{mm}$
 $\varnothing 5,5$ x4

2.
 FI 5,5

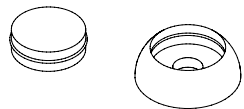
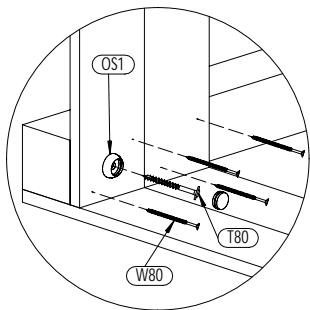
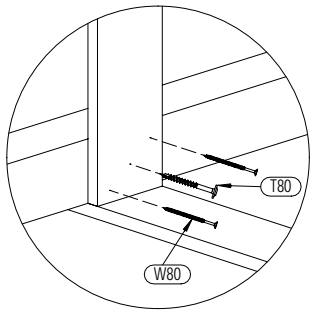

OS1 x2

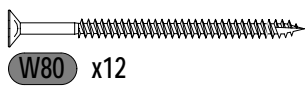

W80 x12

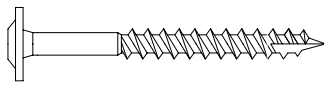

T80 x4

6 3,2x5,8x102,4cm

x2

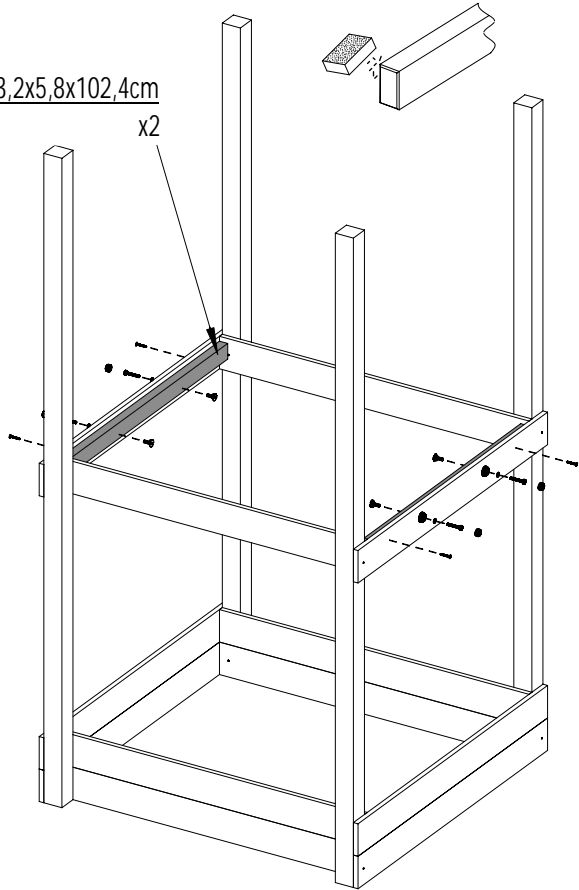

1. $\varnothing 10$ x4

FI 10

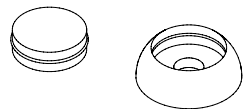

OS1 x4

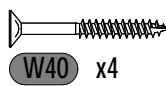

W40 x4

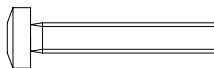

S50 x4

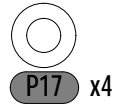

P17 x4

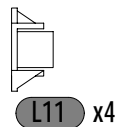
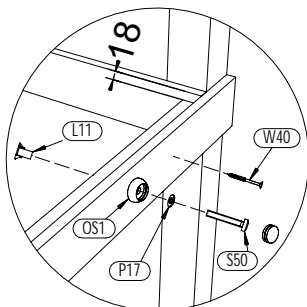

L11 x4

Zgodnie z normą PN-EN 71 stosuj zalecenia producenta odnośnie odległości oraz metody mocowania poszczególnych elementów
In compliance with the standard PN-EN 71, apply guidelines of the producer in relation to distances and methods of fastening individual elements

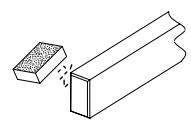
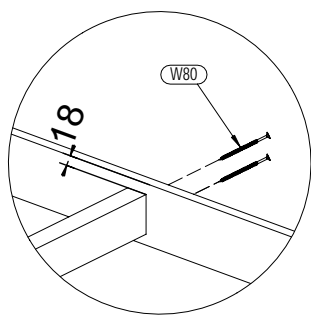

6 3,2x5,8x102,4cm
x1

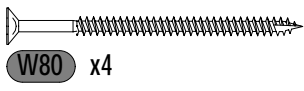
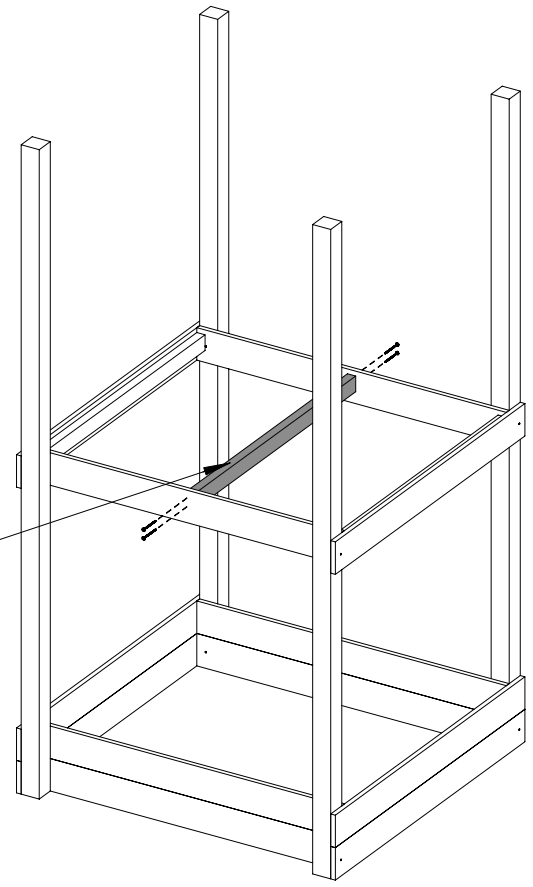

W80 x4

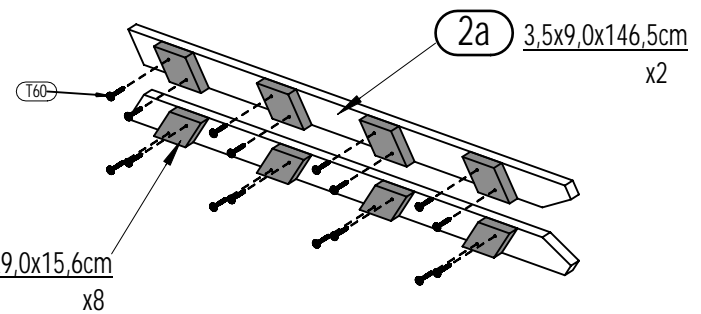

2a 3,5x9,0x146,5cm
x2

3a 3,5x9,0x15,6cm
x8

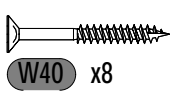
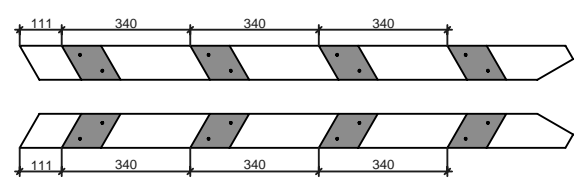
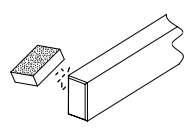

W40 x8

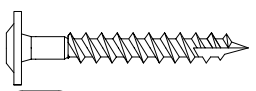

T60 x16



W80 x16

12a 3,2x5,8x41cm
x4

12b 3,2x5,8x41cm
x4

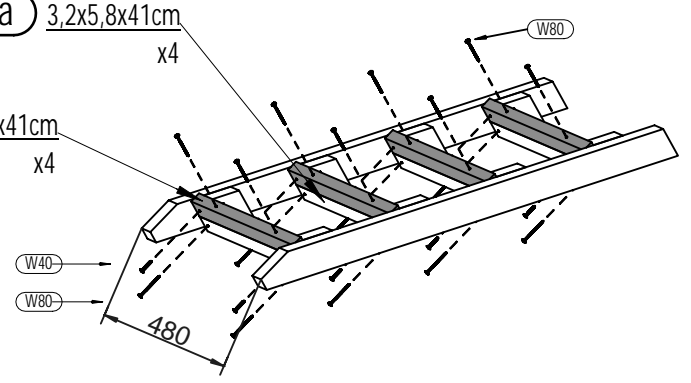

7a 3,2x5,8x100cm
x2

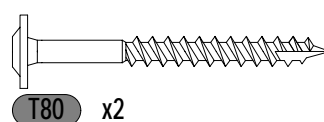
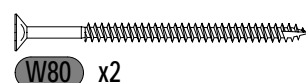
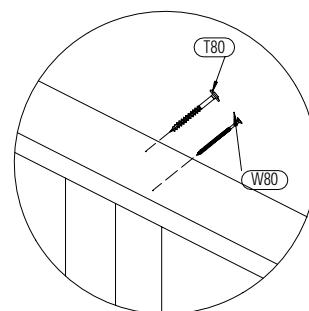
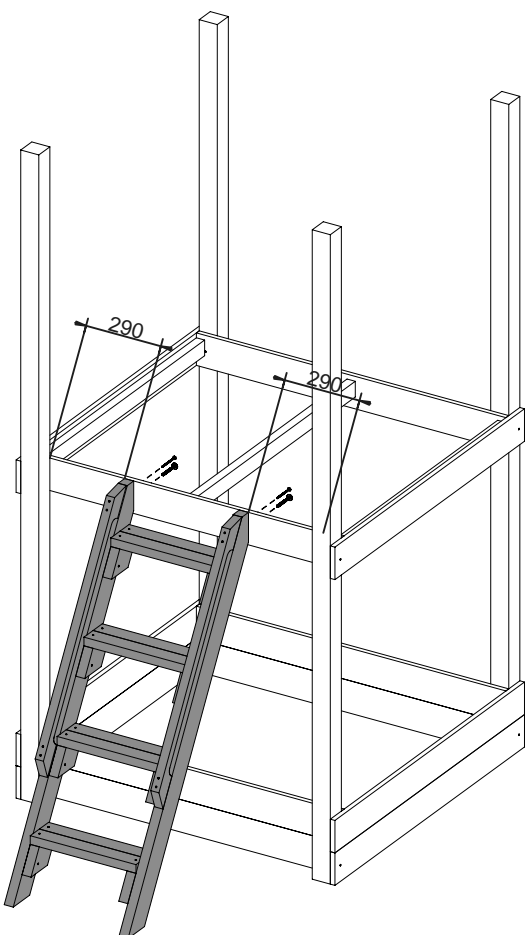
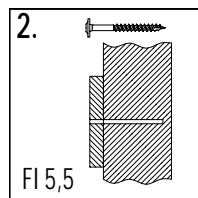
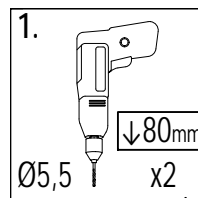
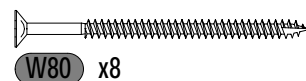
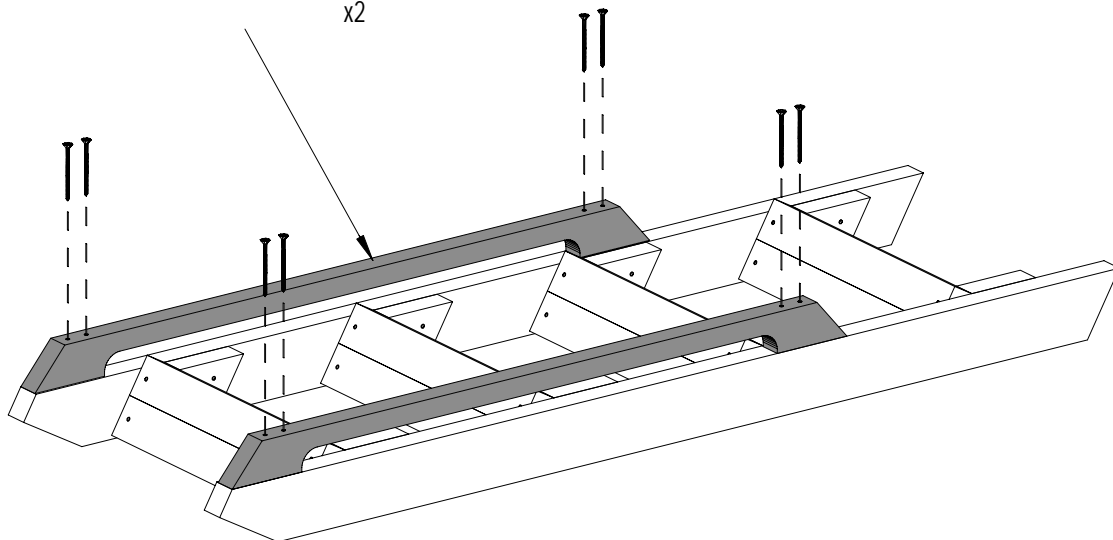

09

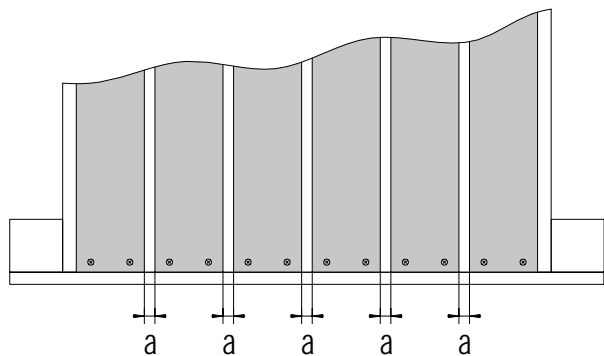
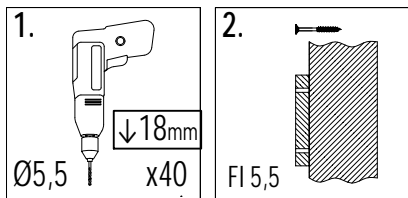

!!!min 13mm < a < !!!max 16mm

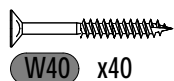
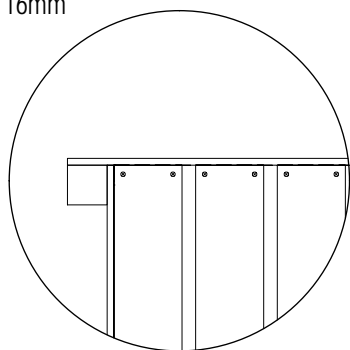

W40 x40

15 1,8x12,0x120cm x8

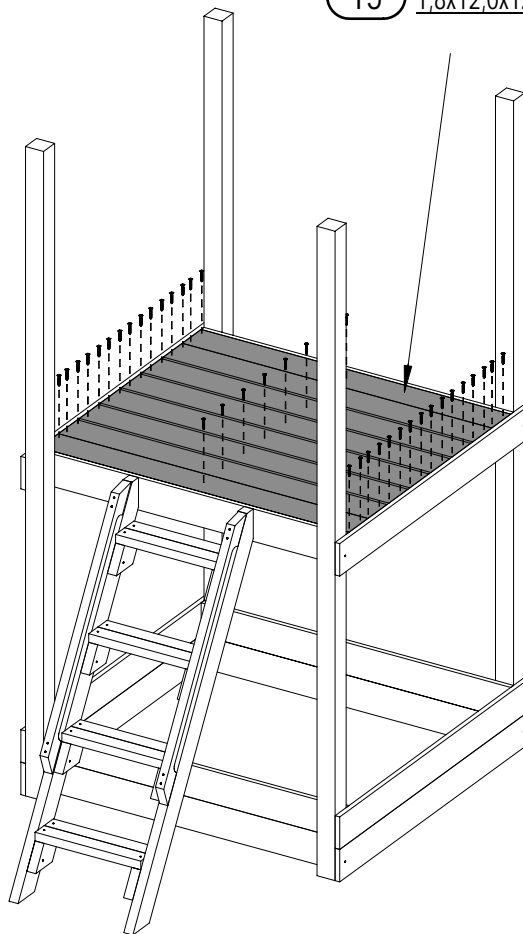

10

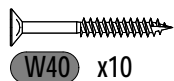
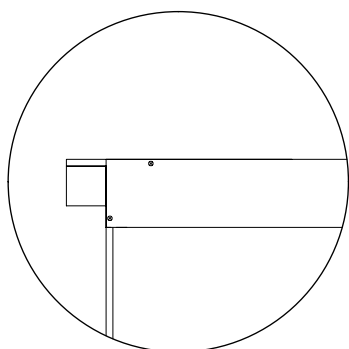
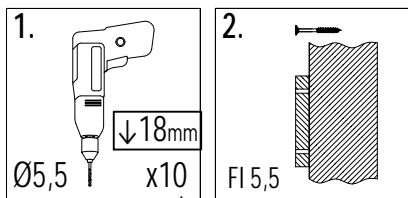

W40 x10

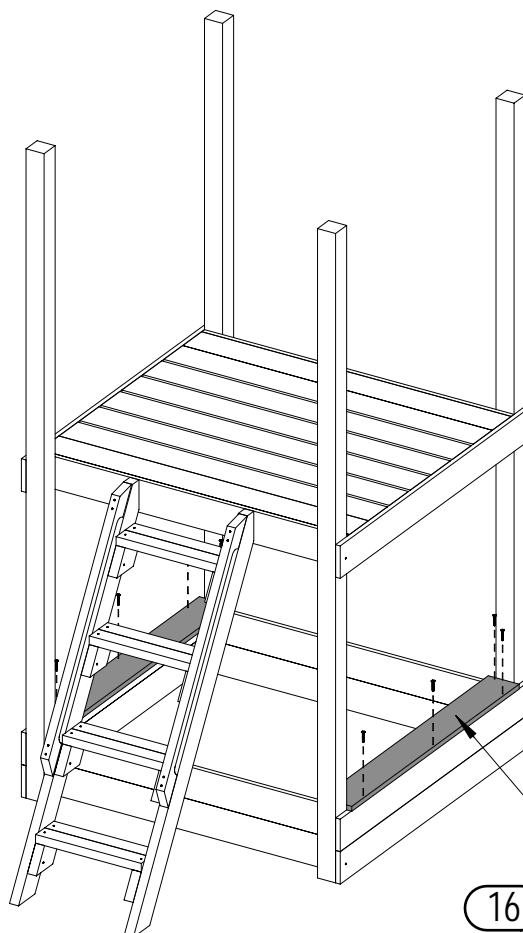

16 1,8x12,0x106cm x2

12

JOY

Zgodnie z normą PN-EN 71 stosuj zalecenia producenta odnośnie odległości oraz metody mocowania poszczególnych elementów
 In compliance with the standard PN-EN 71, apply guidelines of the producer in relation to distances and methods of fastening individual elements

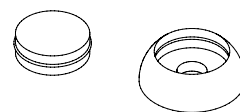
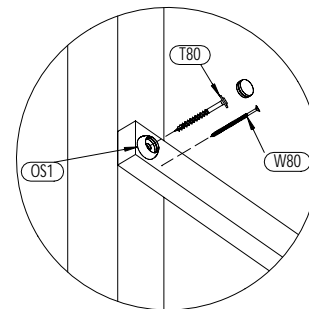
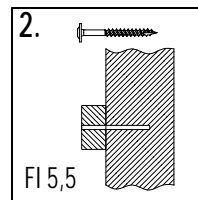
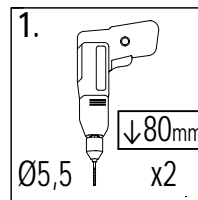
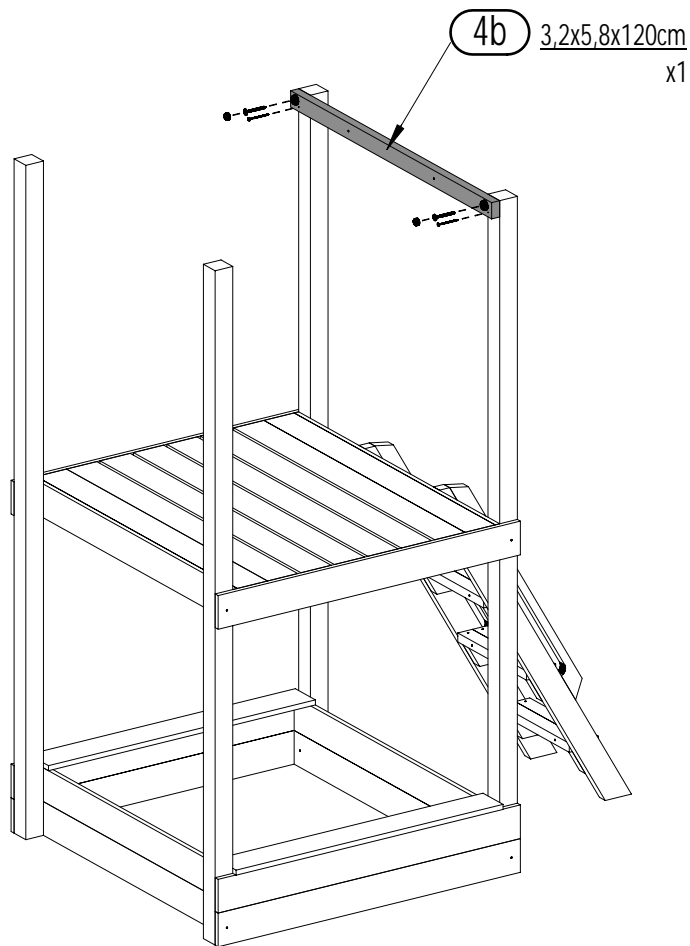

OS1 x2

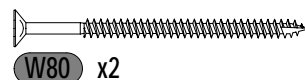

W80 x2

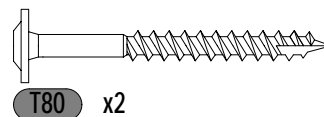

T80 x2

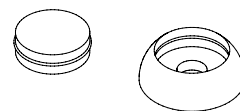
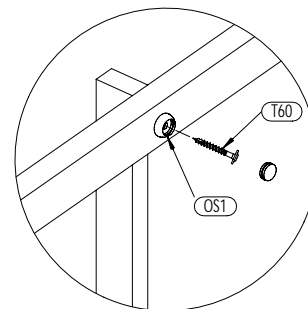
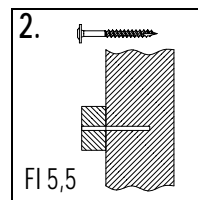
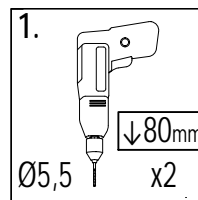
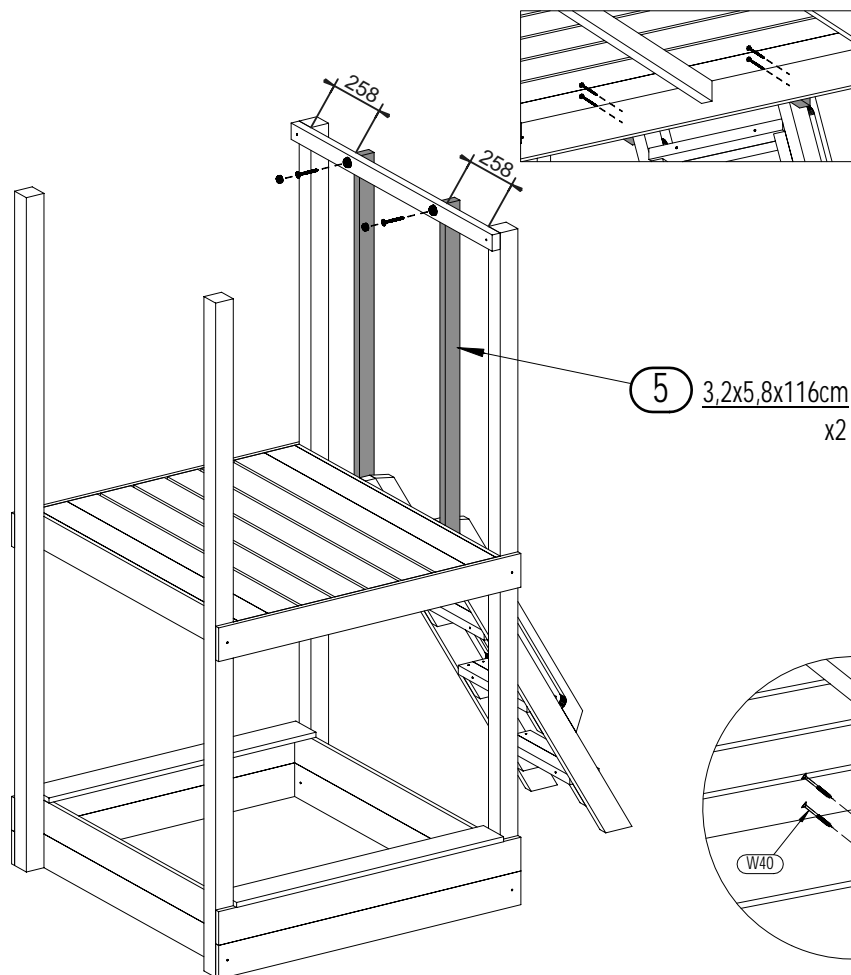

OS1 x2

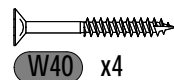

W40 x4

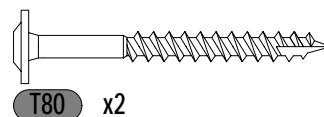

T80 x2

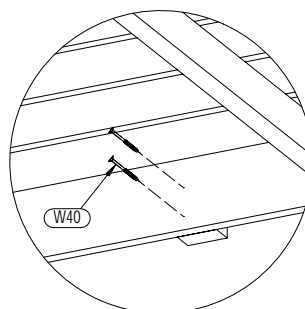

13

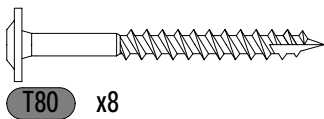
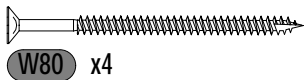
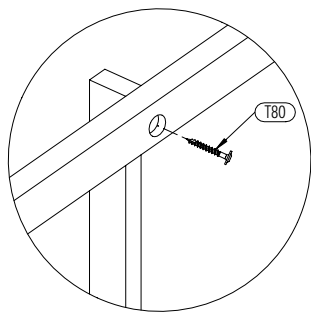
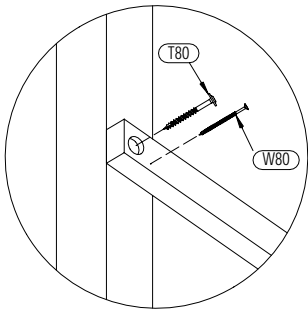
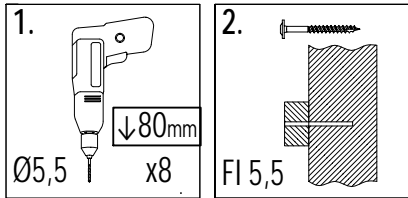

13a 3,2x5,8x36cm x4

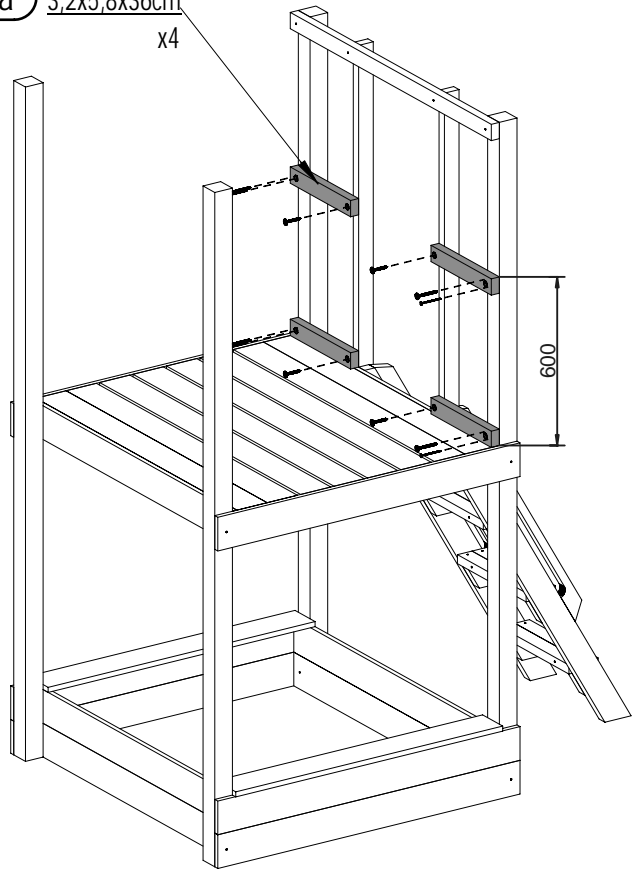

14

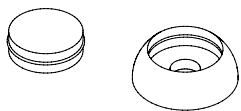
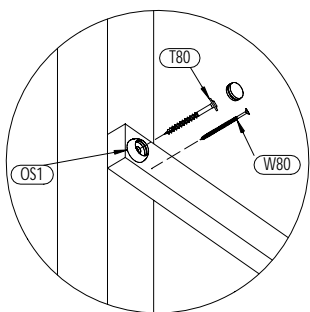
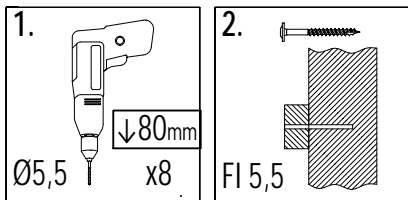

OS1 x8

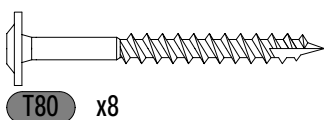
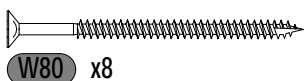

4a 3,2x5,8x120cm x4

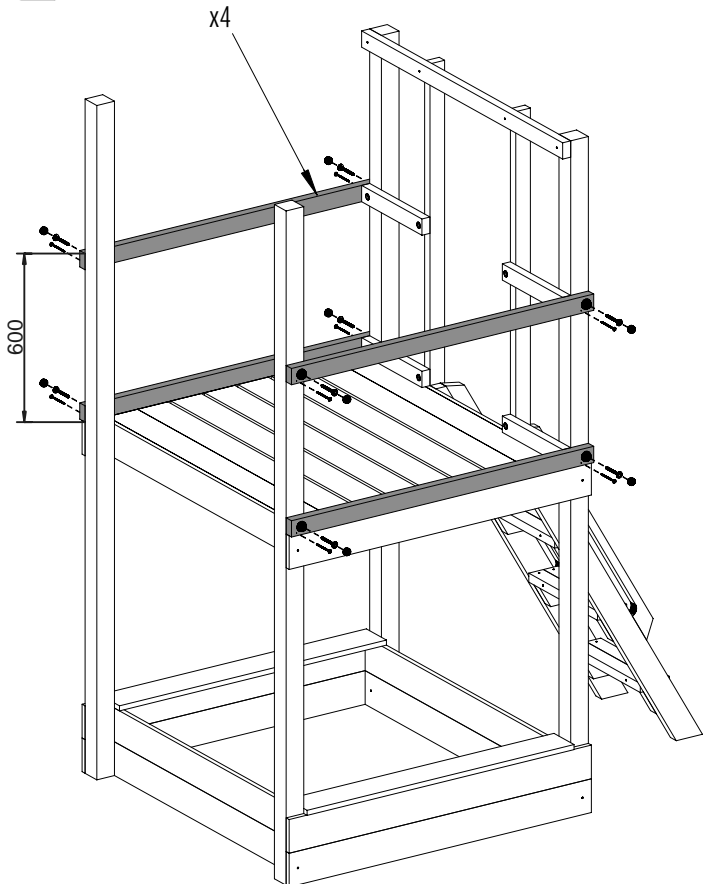

14

JOY

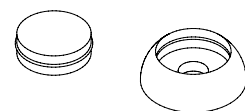
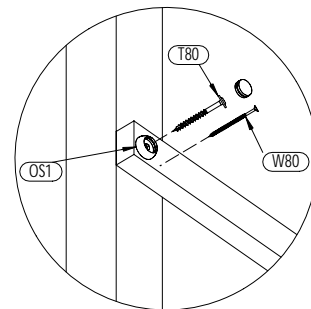
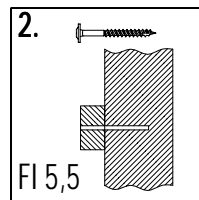
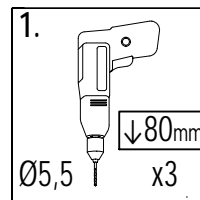
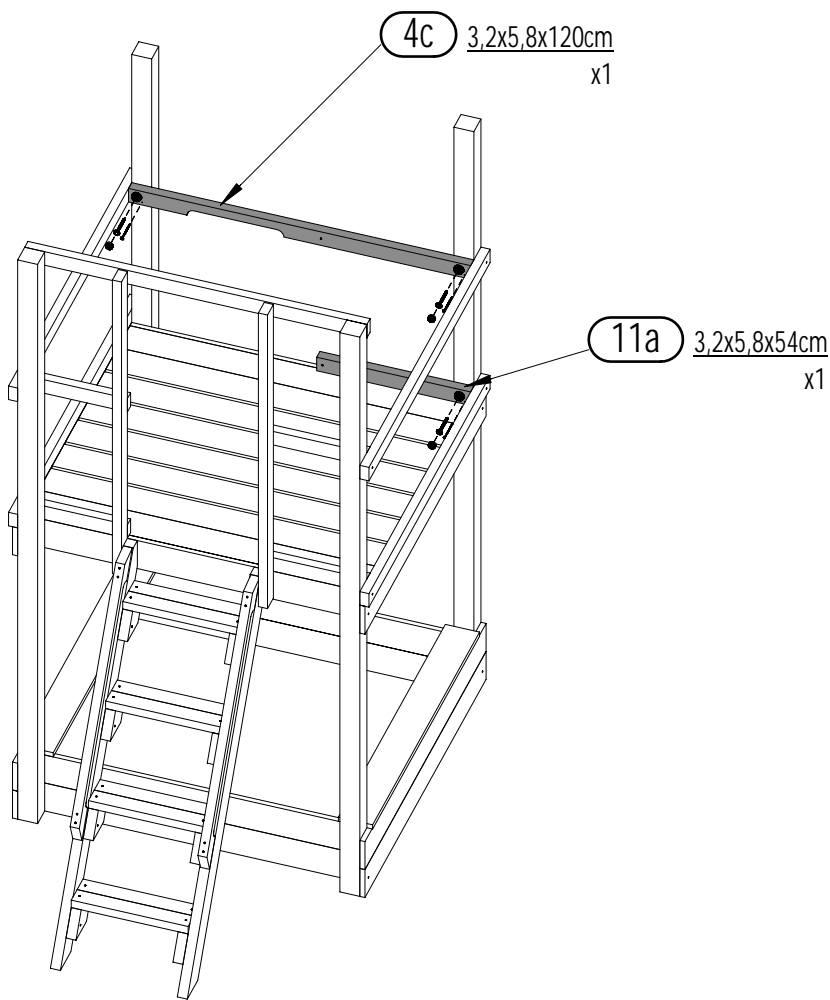

OS1 x3

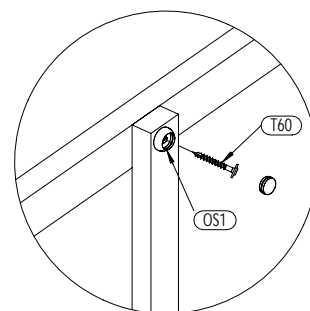
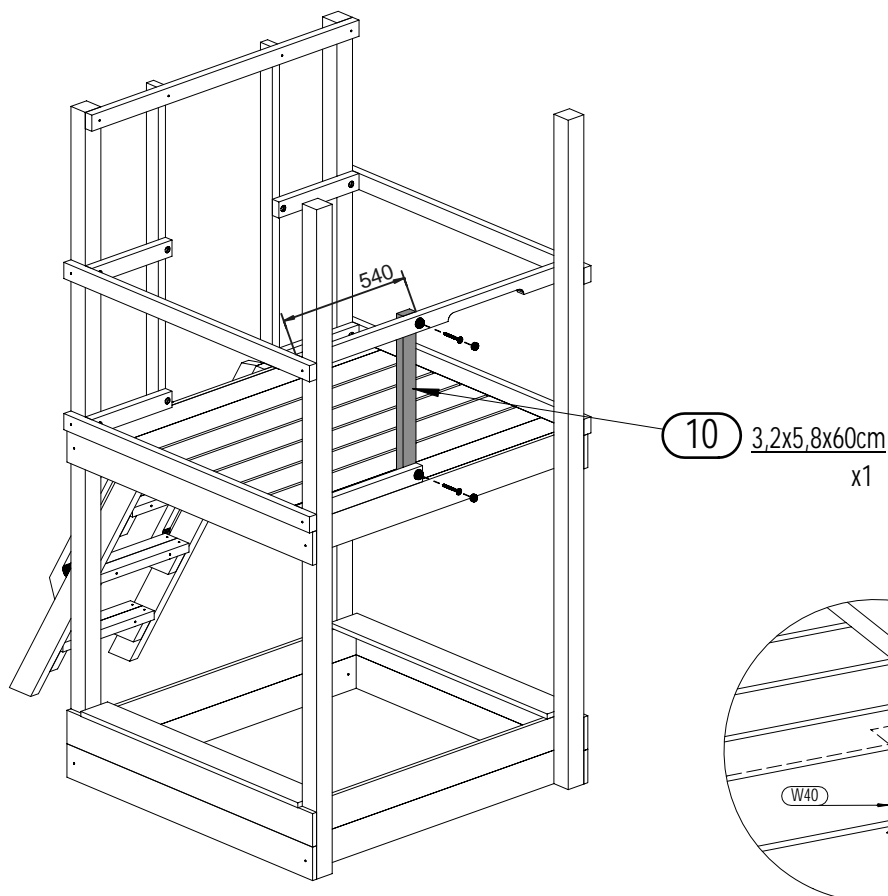
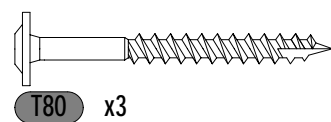
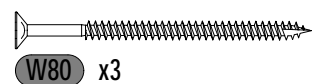

OS1 x2

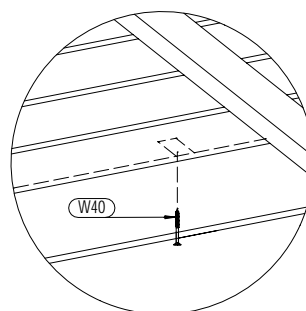
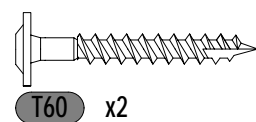
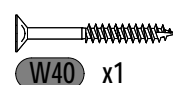

17

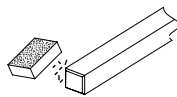
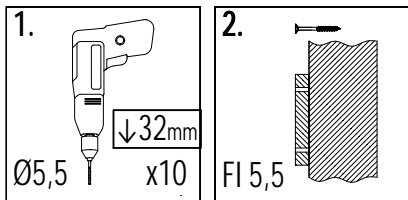

19a 2,7x3,2x54,2cm x1

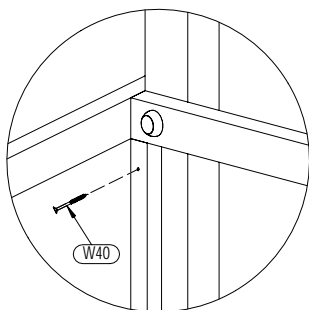

20a 2,7x3,2x48,4cm x4

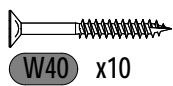
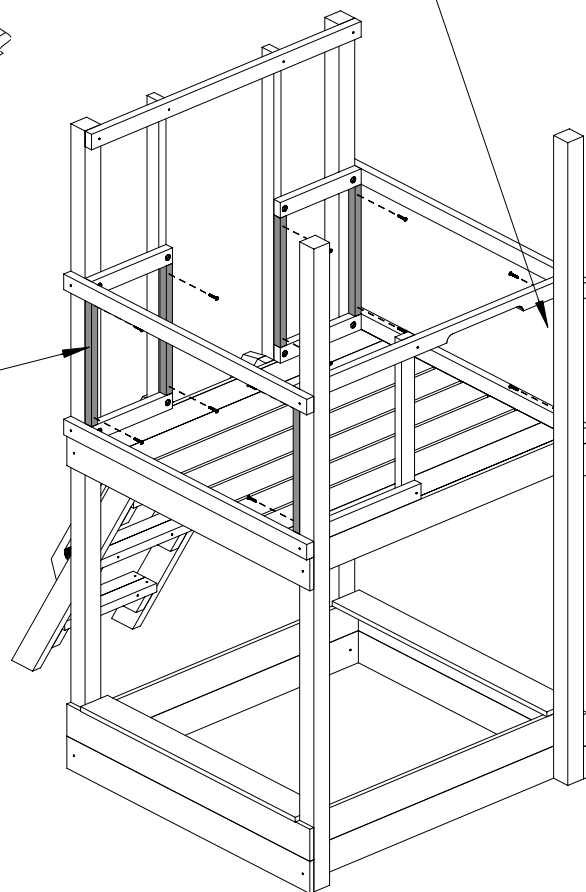

18

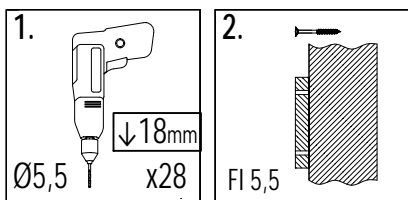

18 1,8x12,0x60cm x7

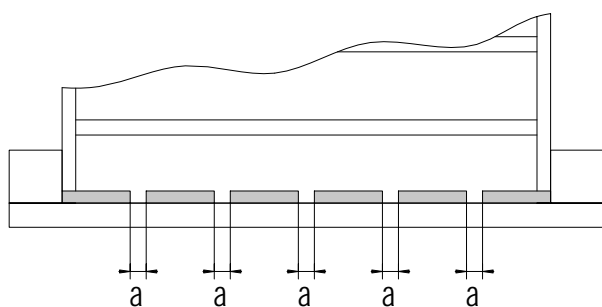

!!!min 13mm < a <!!!max 16mm

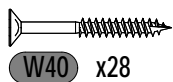
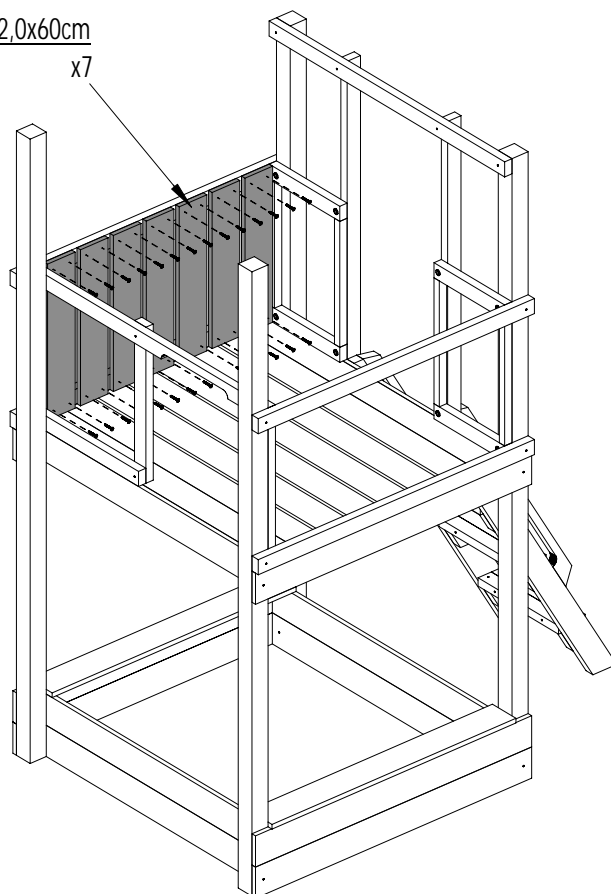

16

JOY

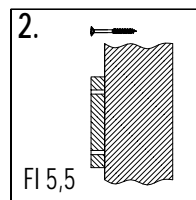
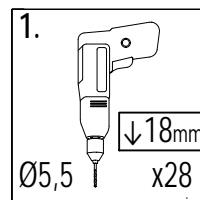
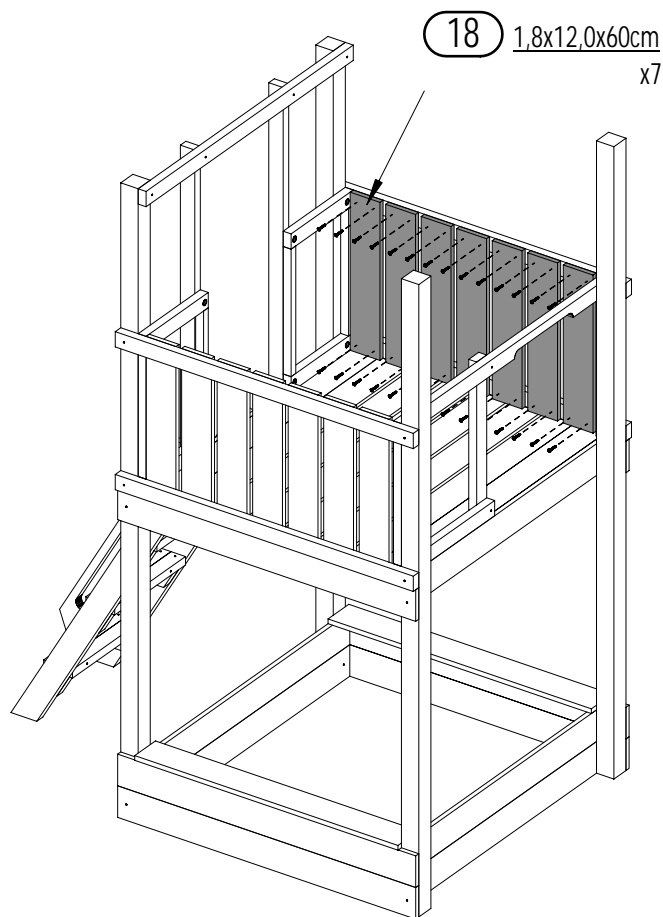

19

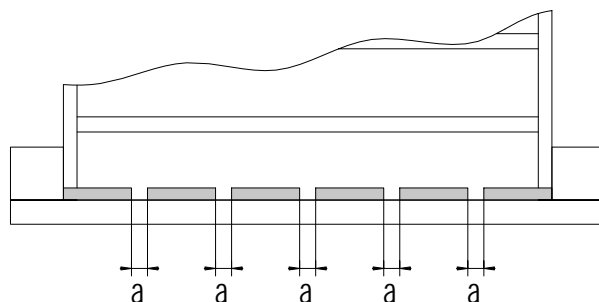

!!!min 13mm < a <!!!max 16mm

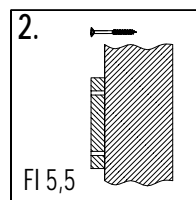
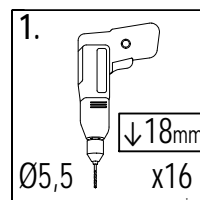
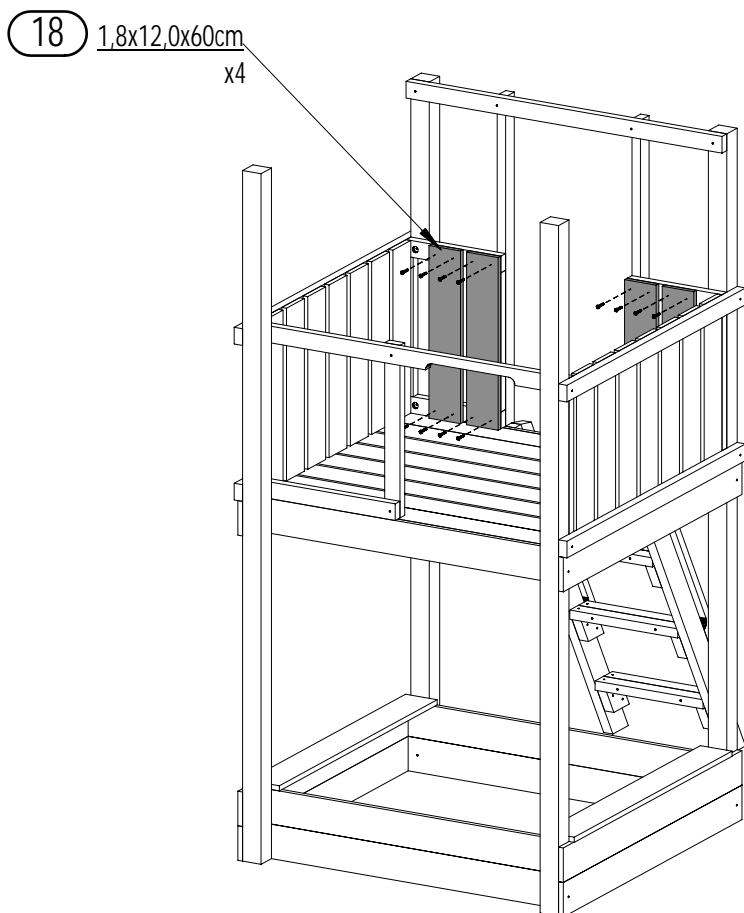
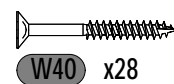

20

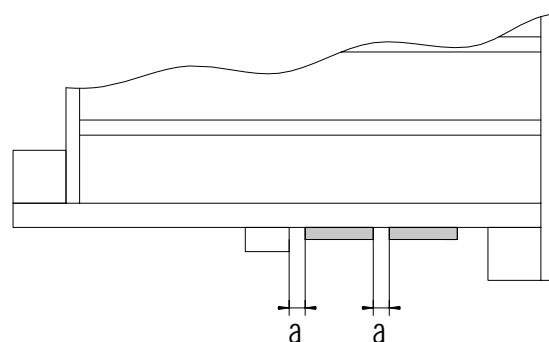

!!!min 13mm < a <!!!max 16mm

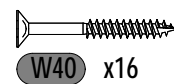

21

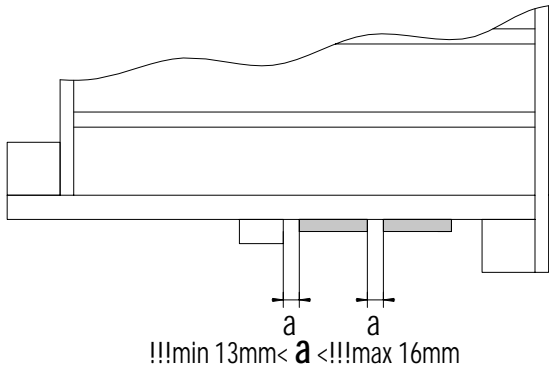
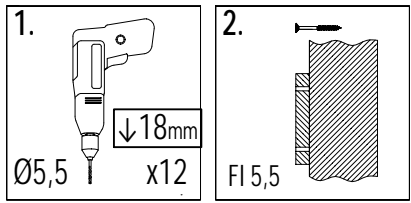

18 1,8x12,0x60cm x3

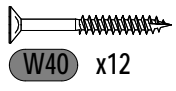
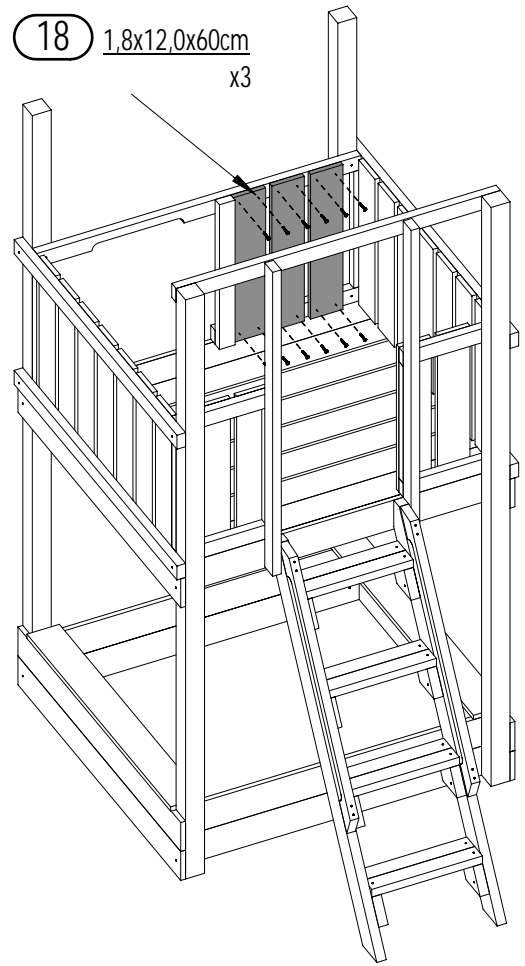

22

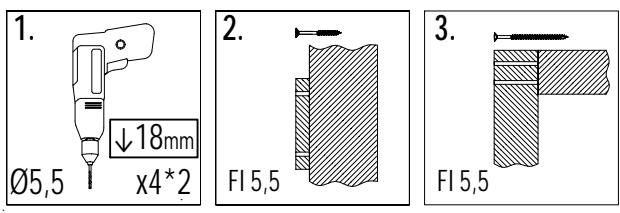

!!! x2

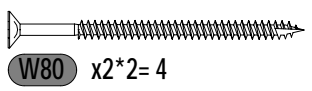
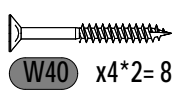
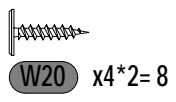
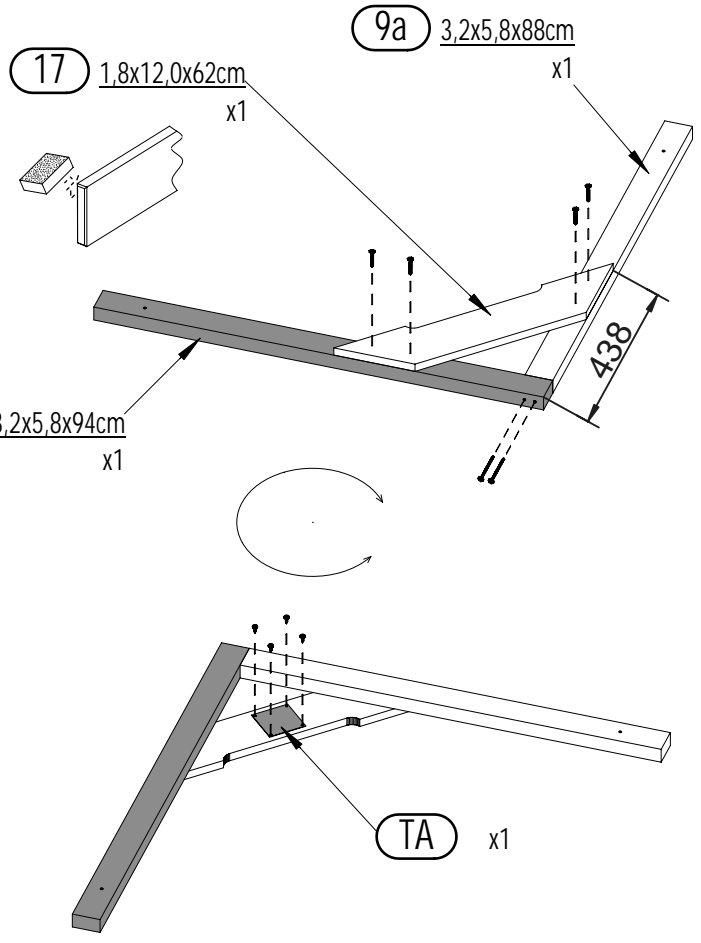

18

JOY

Zgodnie z normą PN-EN 71 stosuj zalecenia producenta odnośnie odległości oraz metody mocowania poszczególnych elementów
 In compliance with the standard PN-EN 71, apply guidelines of the producer in relation to distances and methods of fastening individual elements

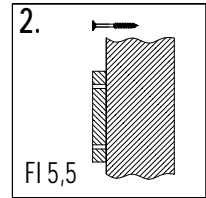
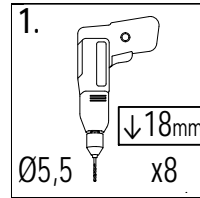
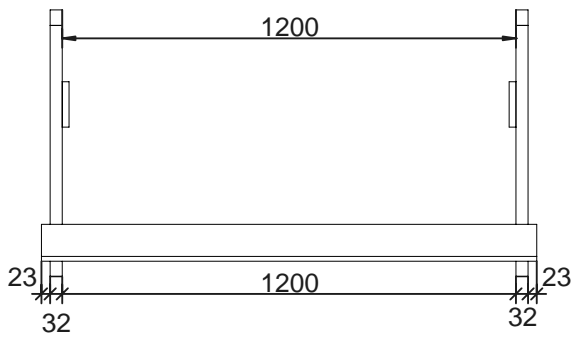

23

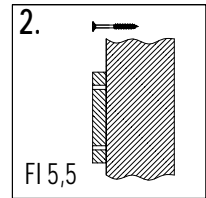
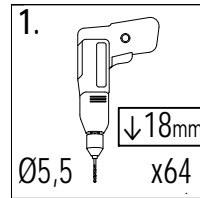
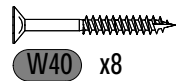
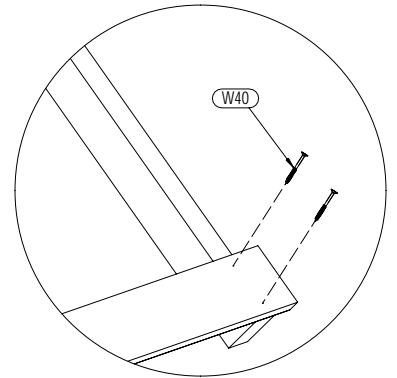
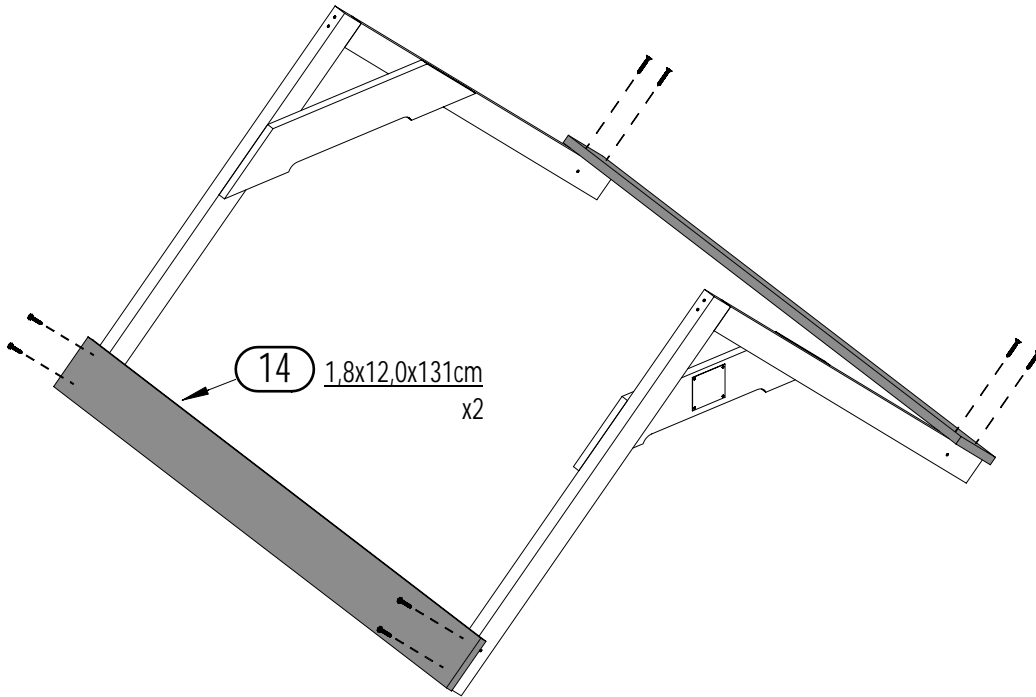

24

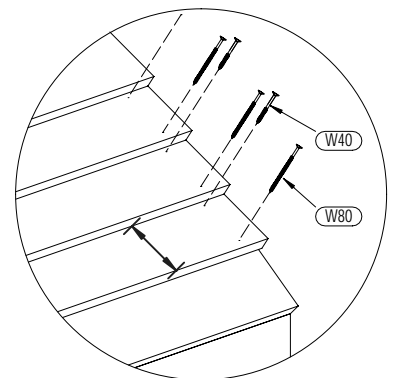
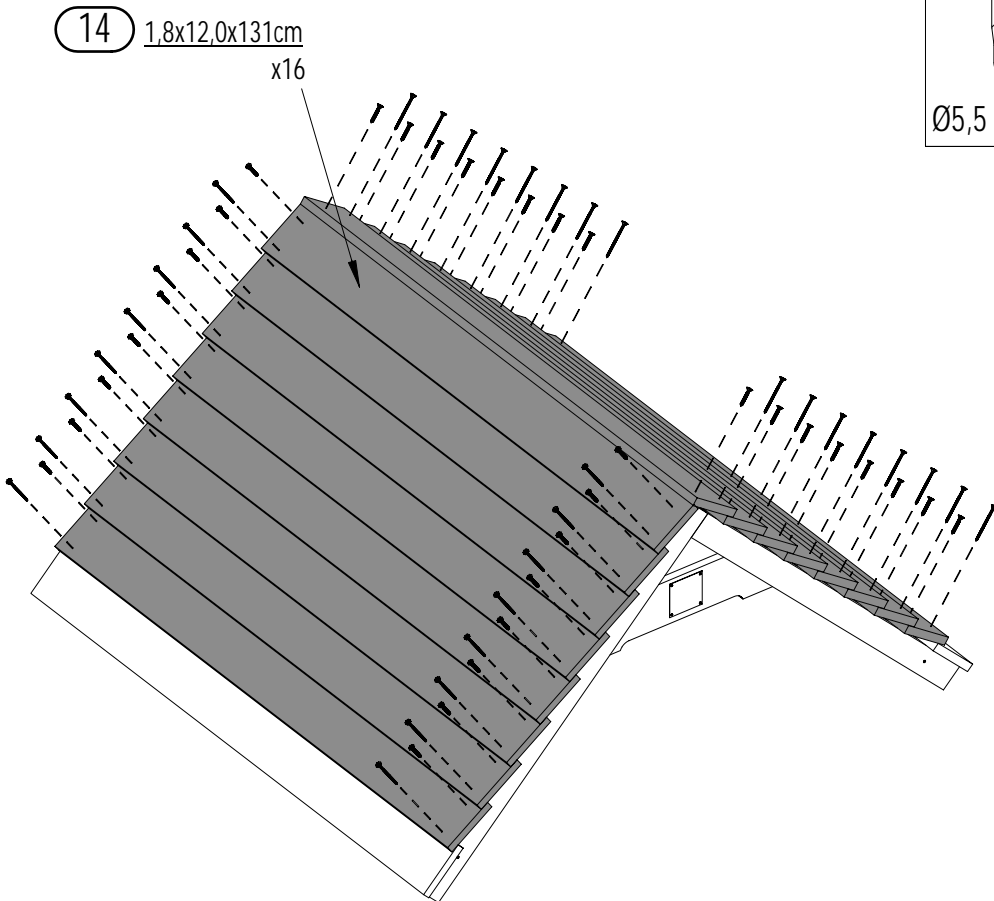

a = 104mm

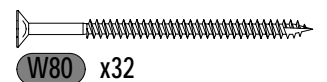
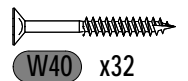

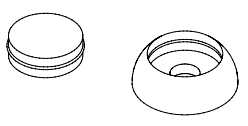
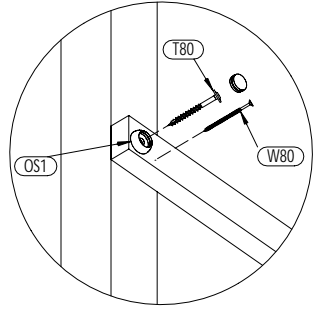
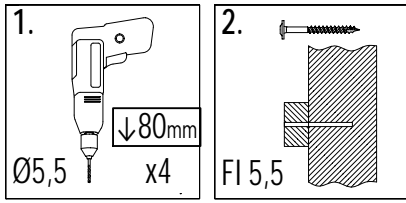

OS1 x4

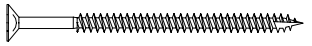

W80 x4

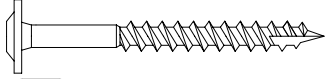

T80 x4

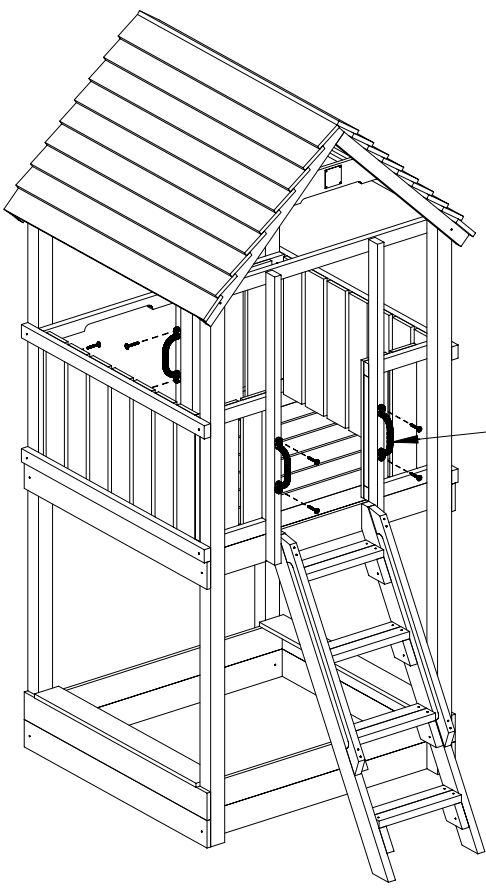
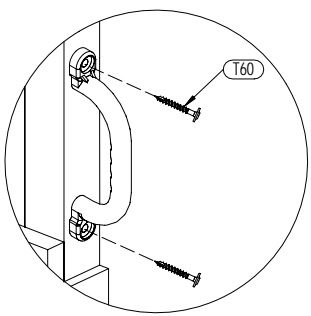
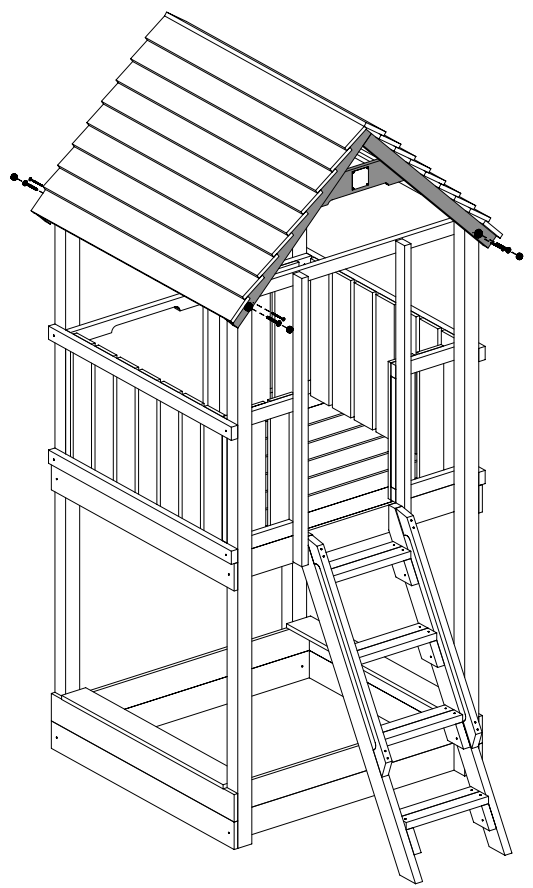

UC x4

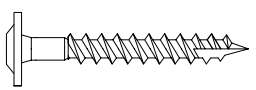

T60 x8

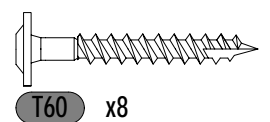
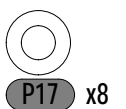
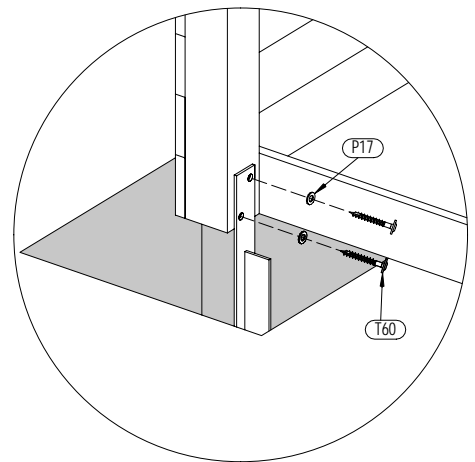
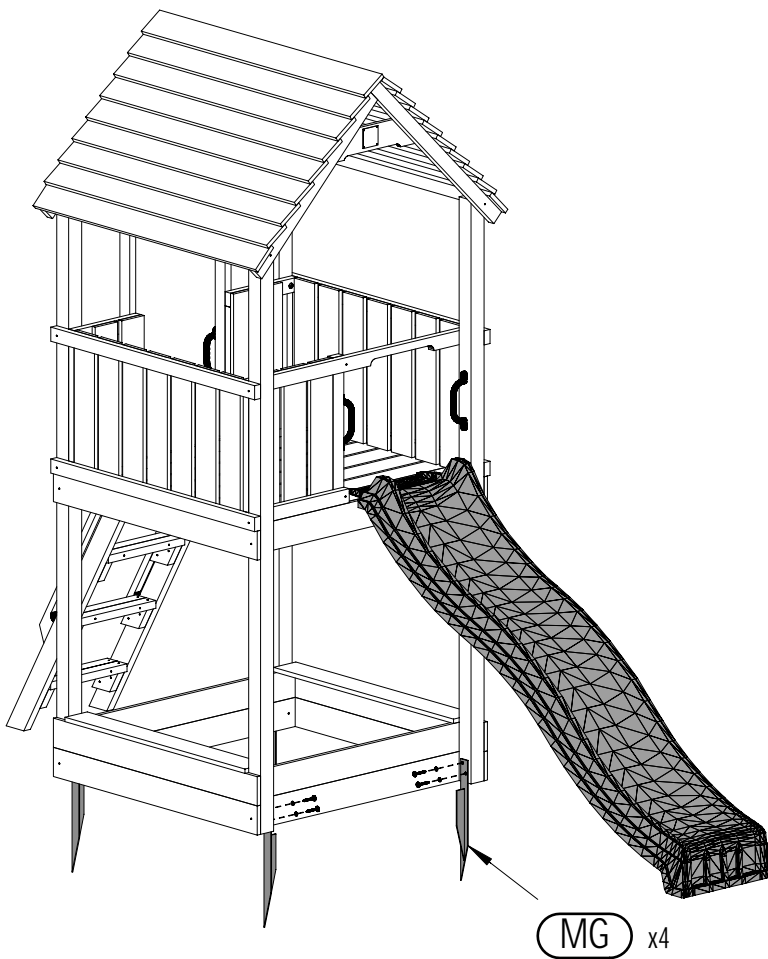
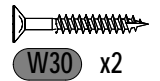
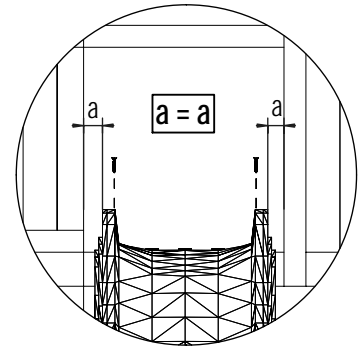
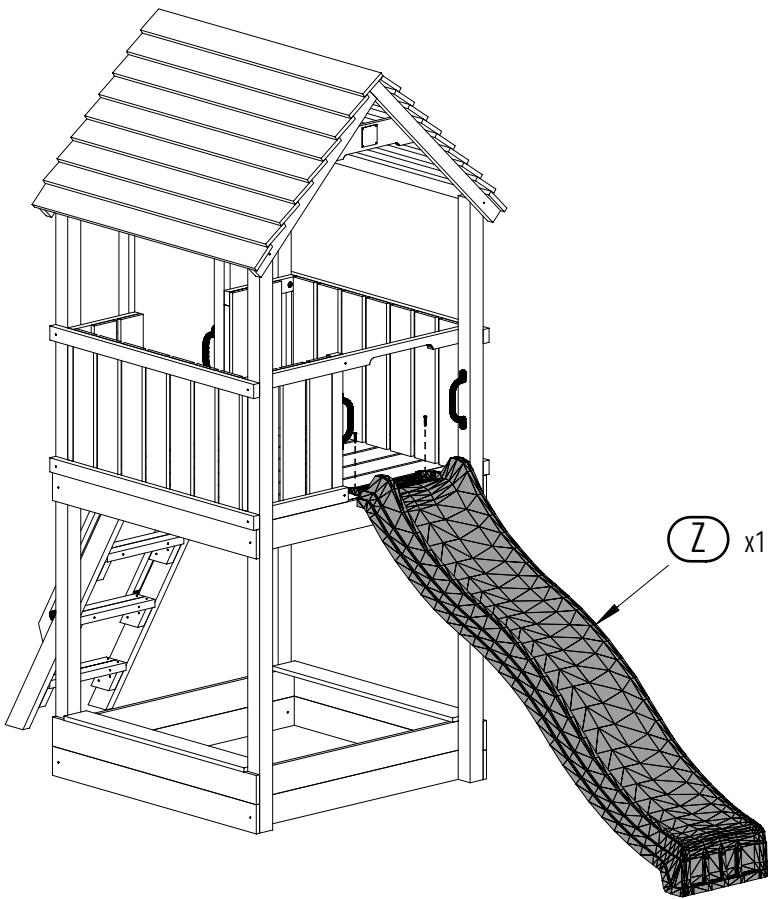

29

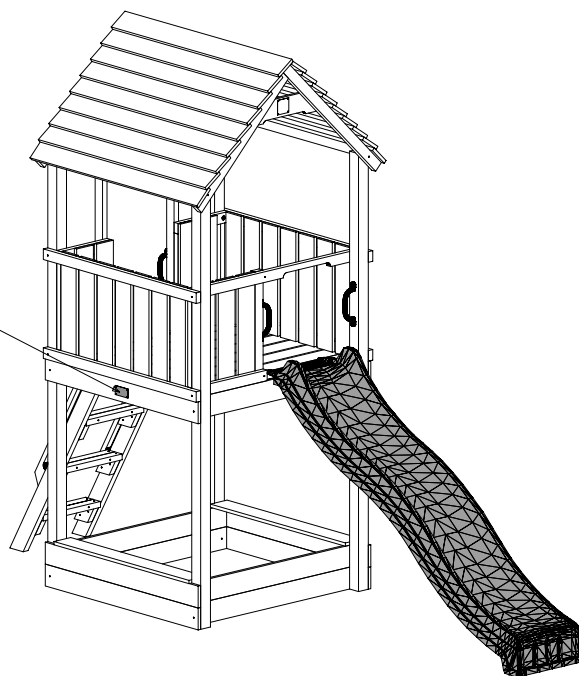
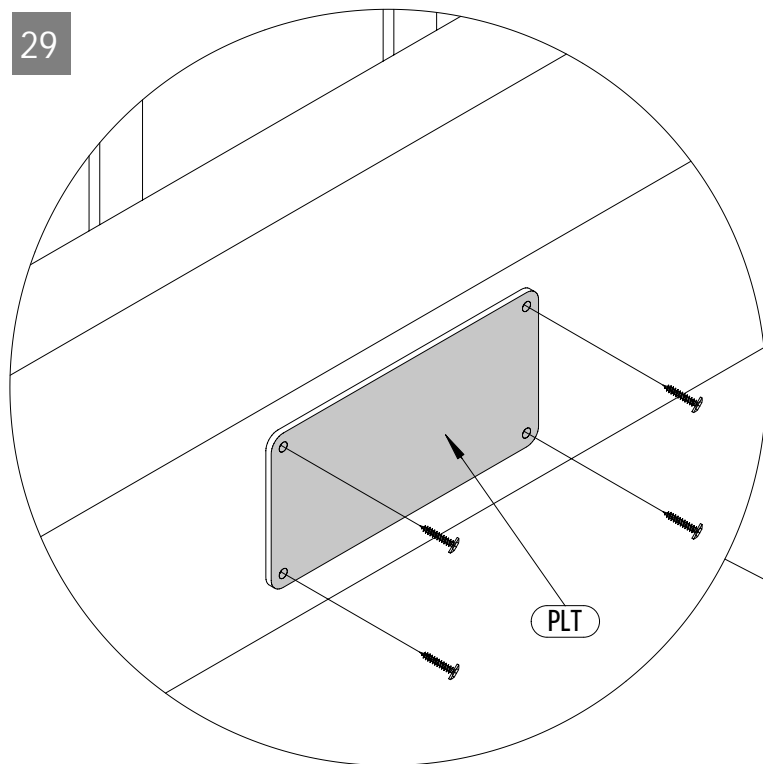

W20 x4

30

22

JOY

Zgodne z normą PN-EN 71 stosuj zalecenia producenta odnośnie odległości oraz metody mocowania poszczególnych elementów
In compliance with the standard PN-EN 71, apply guidelines of the producer in relation to distances and methods of fastening individual elements

PLAYGROUND SPIELPLATZ

PLAC ZABAW AIRE DE JEUX

(305 x 253 x h240cm)

003_00650_02062021

MOVE PLUS

INSTALLATION INSTRUCTIONS
MONTAGEANLEITUNG

INSTRUKCJA MONTAŻU
GUIDE D'INSTALLATION

Warranty period - 2 years from purchase date

Garantiezeit - 2 Jahre ab Kaufdatum

Okres gwarancji - 2 lata od momentu zakupu towaru

Période de garantie - 2 ans à compter de l'achat

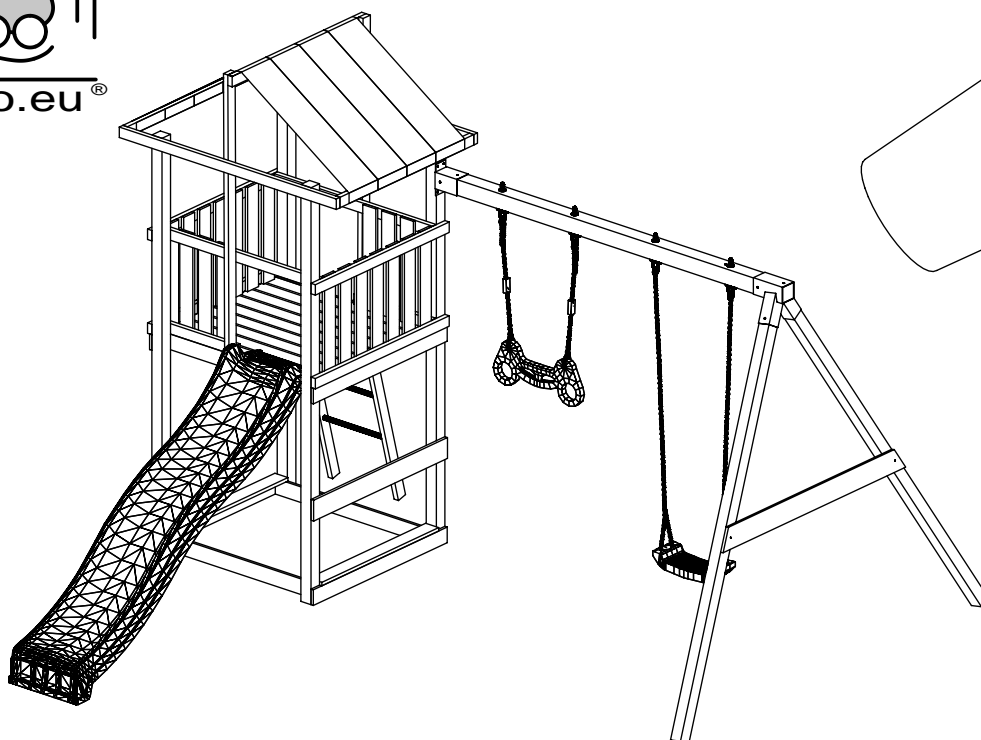

EN - 71

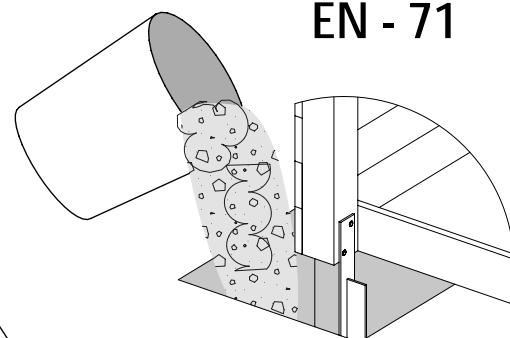

WARNINGS!

Only for home use.

Dedicated for external use only.

Not suitable for children under 3 years old.

Risk of falling down and/or hitting.

Maximum user weight is up to 50 kg.

Maximum number of users staying on the playground at the same time: 2.

OSTRZEŻENIA!

Tylko do użytku domowego.

Przeznaczony do użytku na zewnątrz.

Nie przeznaczony dla dzieci poniżej 3 roku życia.

Niebezpieczeństwo upadku i/lub uderzenia.

Maksymalna waga użytkownika to 50 kg.

Maksymalna liczba użytkowników przebywających na placu zabaw w tym samym czasie: 2.

ACHTUNG!

Nur für den privaten, häuslichen Bereich.

Ausschließlich für die Verwendung im Freien.

Nicht geeignet für Kinder unter 3 Jahren.

Stolper- und / oder Sturzgefahr

Höchstgewicht pro Einzelkind beträgt 50 kg

Der Aufenthalt auf diesem Spielturm ist max. : 2.

Kindern gleichzeitig erlaubt.

AVERTISSEMENT!

Aire exclusivement destinée à un usage privé.

Aire exclusivement destinée à un usage en extérieur.

Prévue pour les enfants de plus de 3 ans.

Danger de chute ou de choc.

Poids maximal d'un utilisateur : 50 kg.

Nombre maximal d'utilisateurs présents en même temps sur la même aire de jeux: 2.

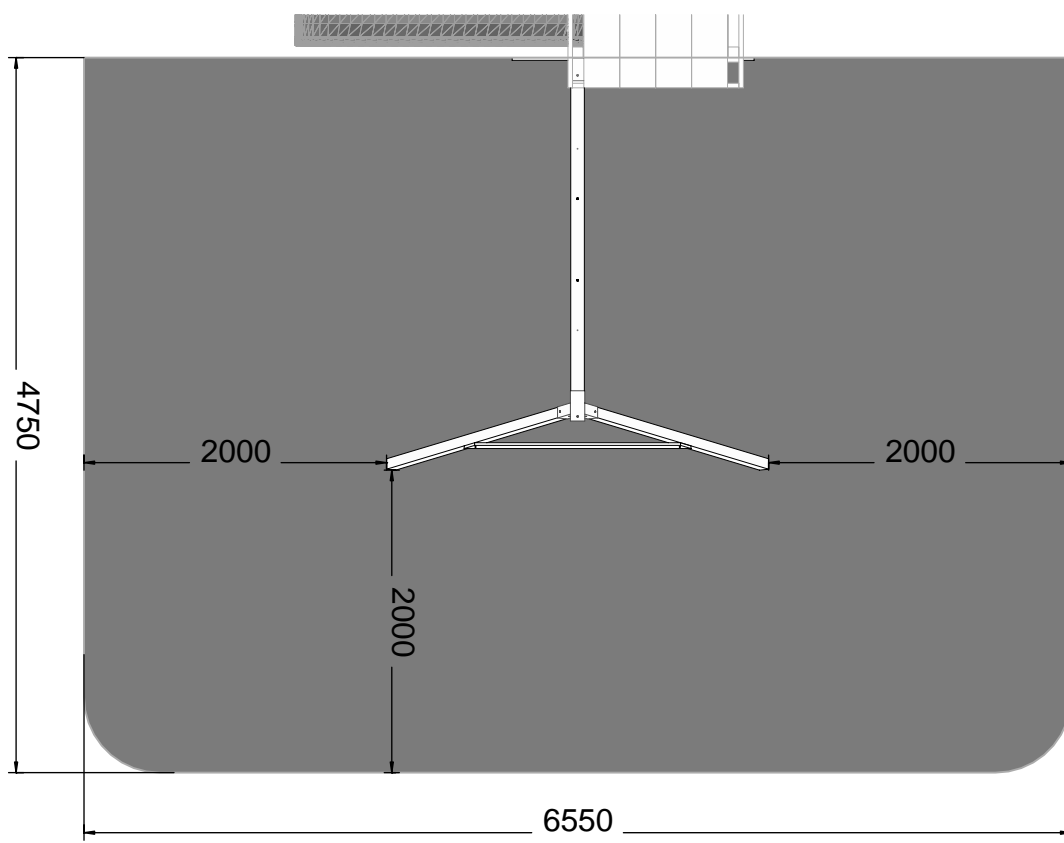

(W80) x8



(T80) x4

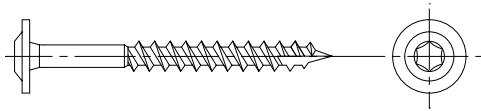

(T60) x17

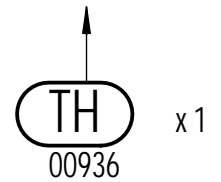
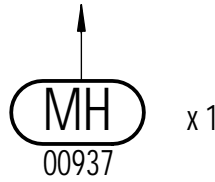
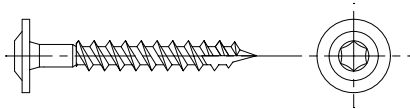

(P17) x17

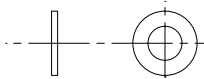

(OS1) x4

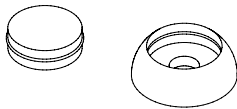

(W20) x4

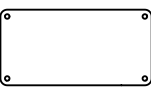
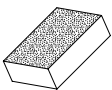

PLT
00197

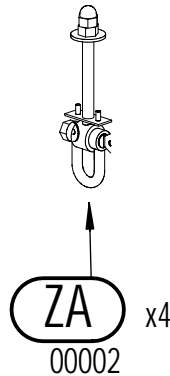

ZA
00002

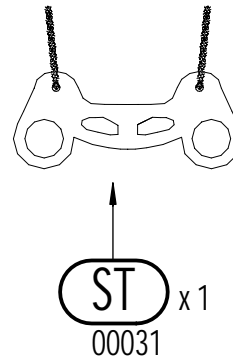

ST
00031

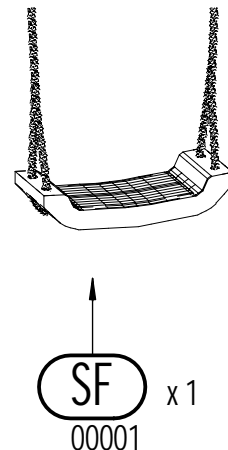

SF
00001

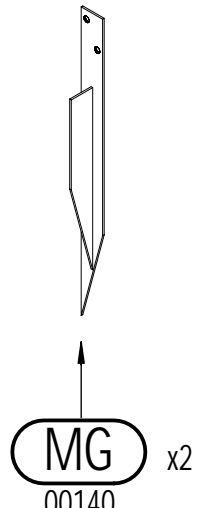

MG
00140

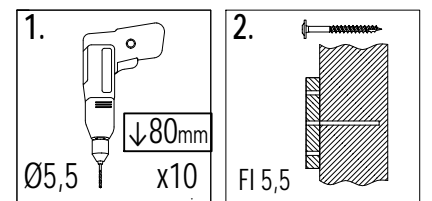
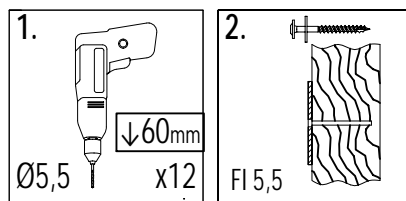
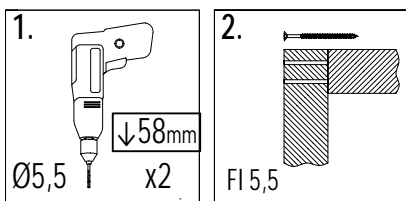
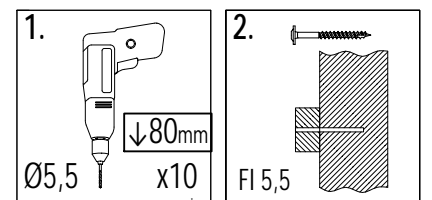
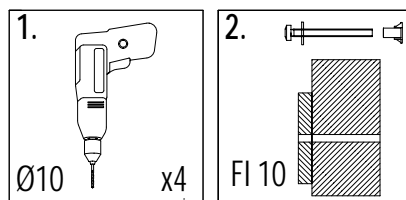
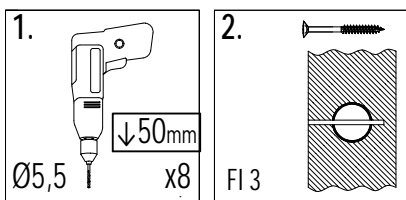
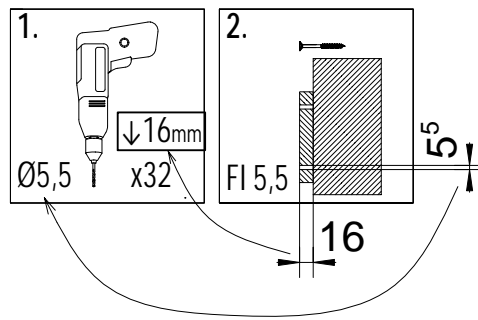
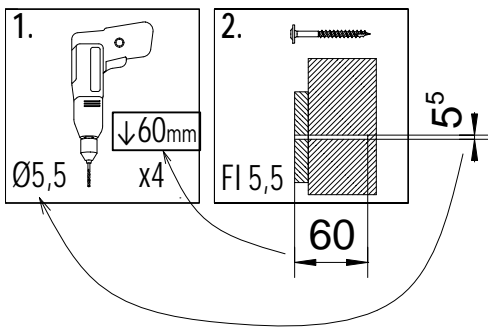
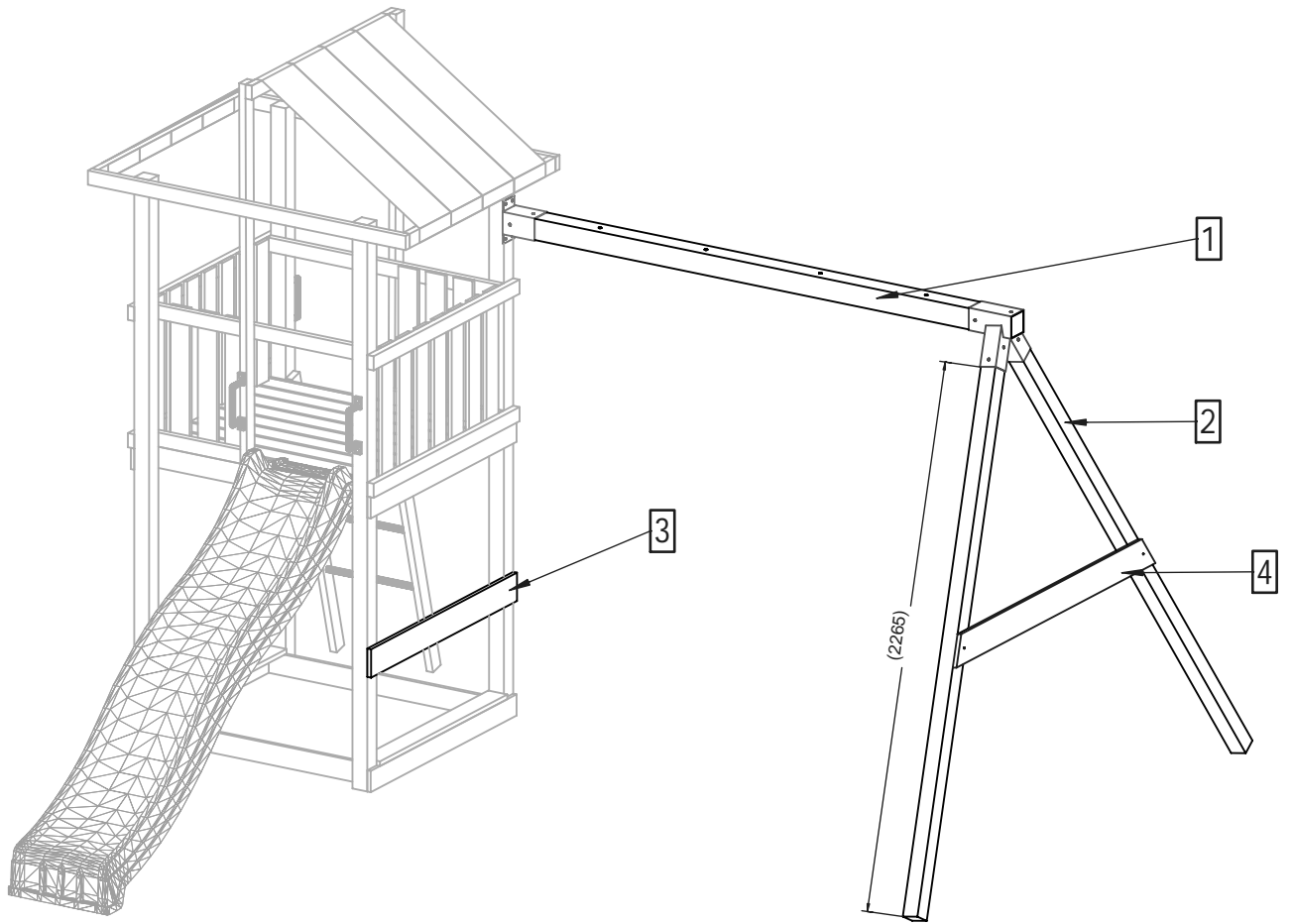

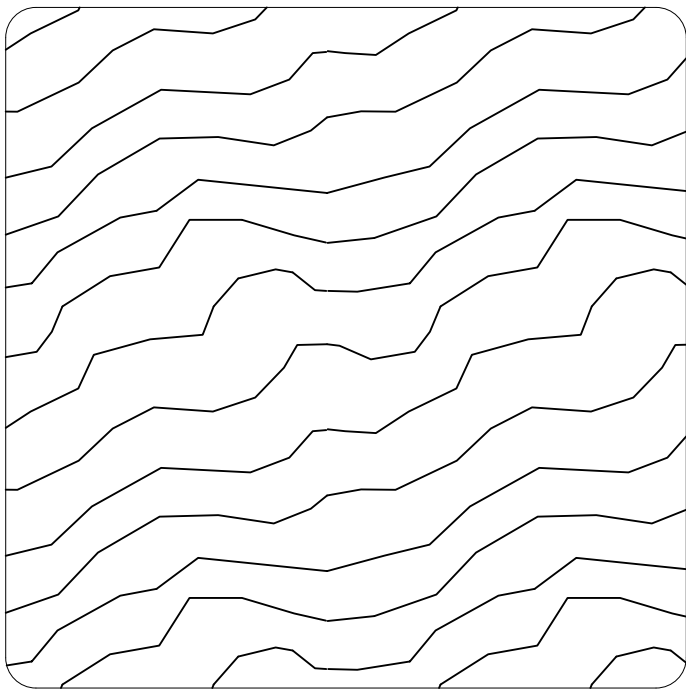

9,0 x 9,0 cm

Lp.	Kod	Wymiary [mm]	szt.
1a	06335	90x90x2400mm	1

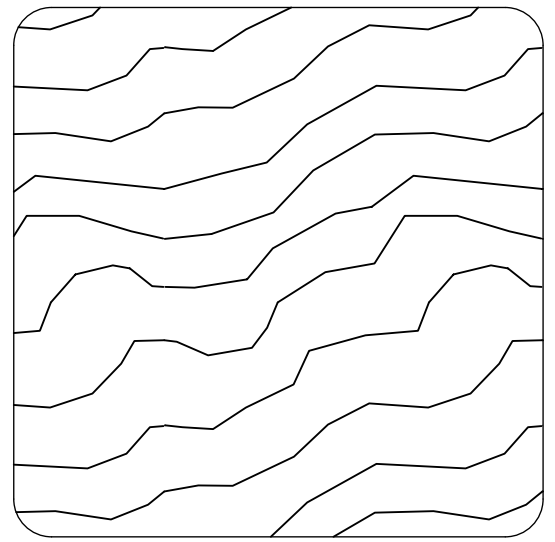

7,0 x 7,0 cm

Lp.	Kod	Wymiary [mm]	szt.
2	04405	70x70x2400mm	2

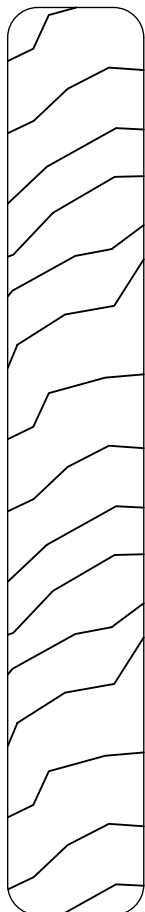

1,8 x 12,0 cm

Lp.	Kod	Wymiary [mm]	szt.
3	01418	18x120x1600mm	1
4a	00133	18x120x1500mm	1

1a

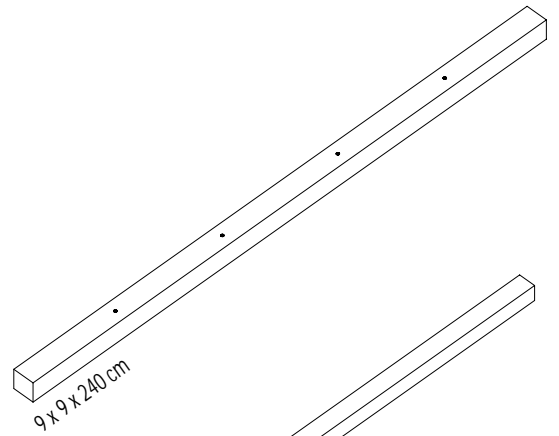

2

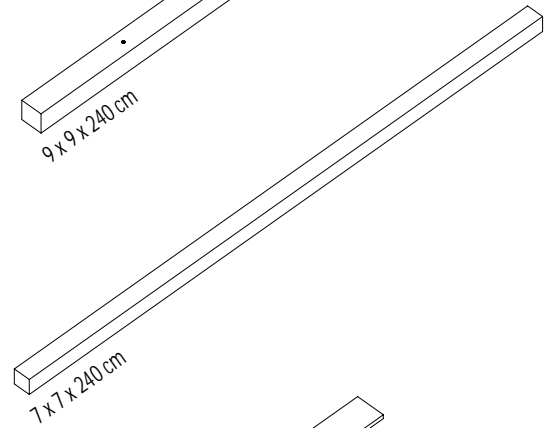

3

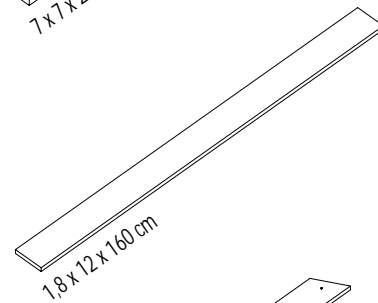

4a

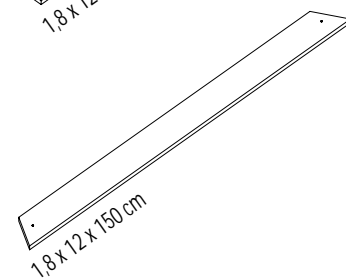

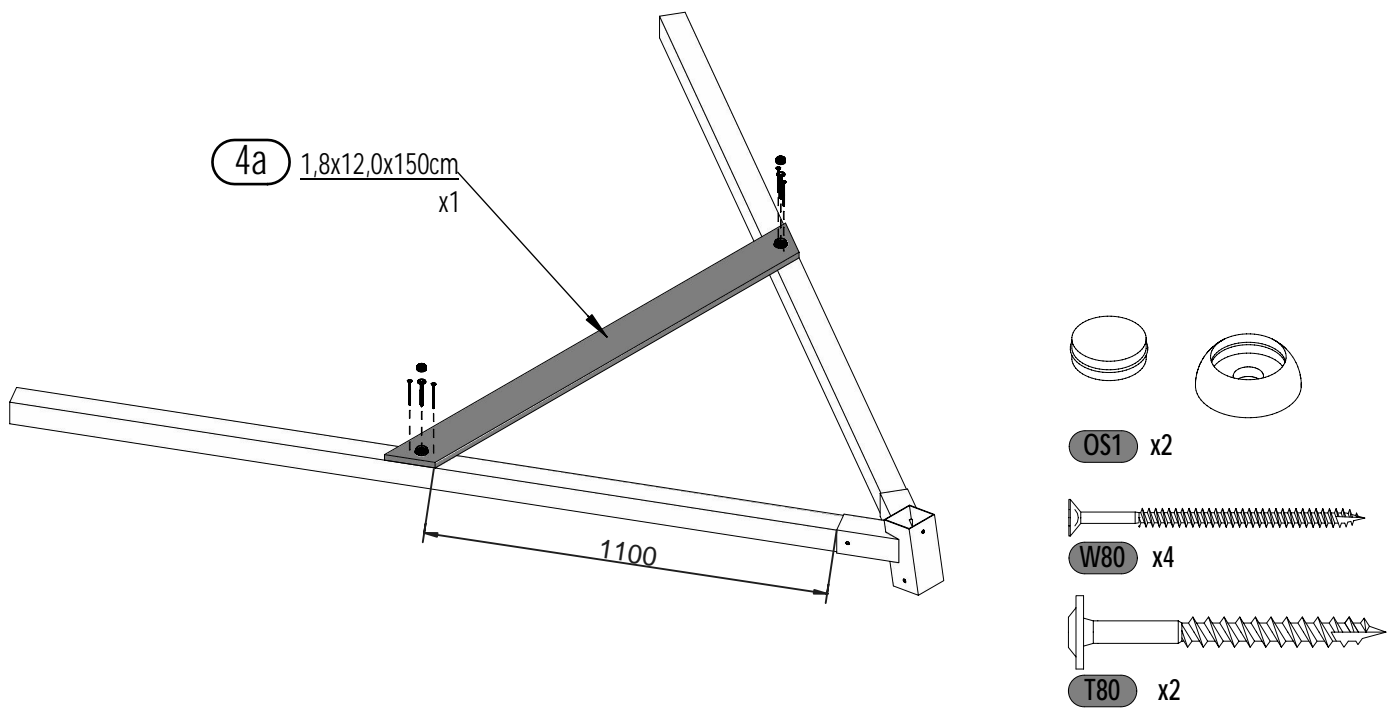
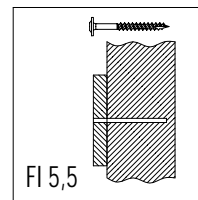
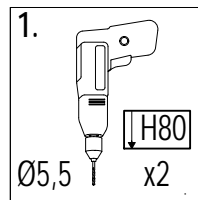
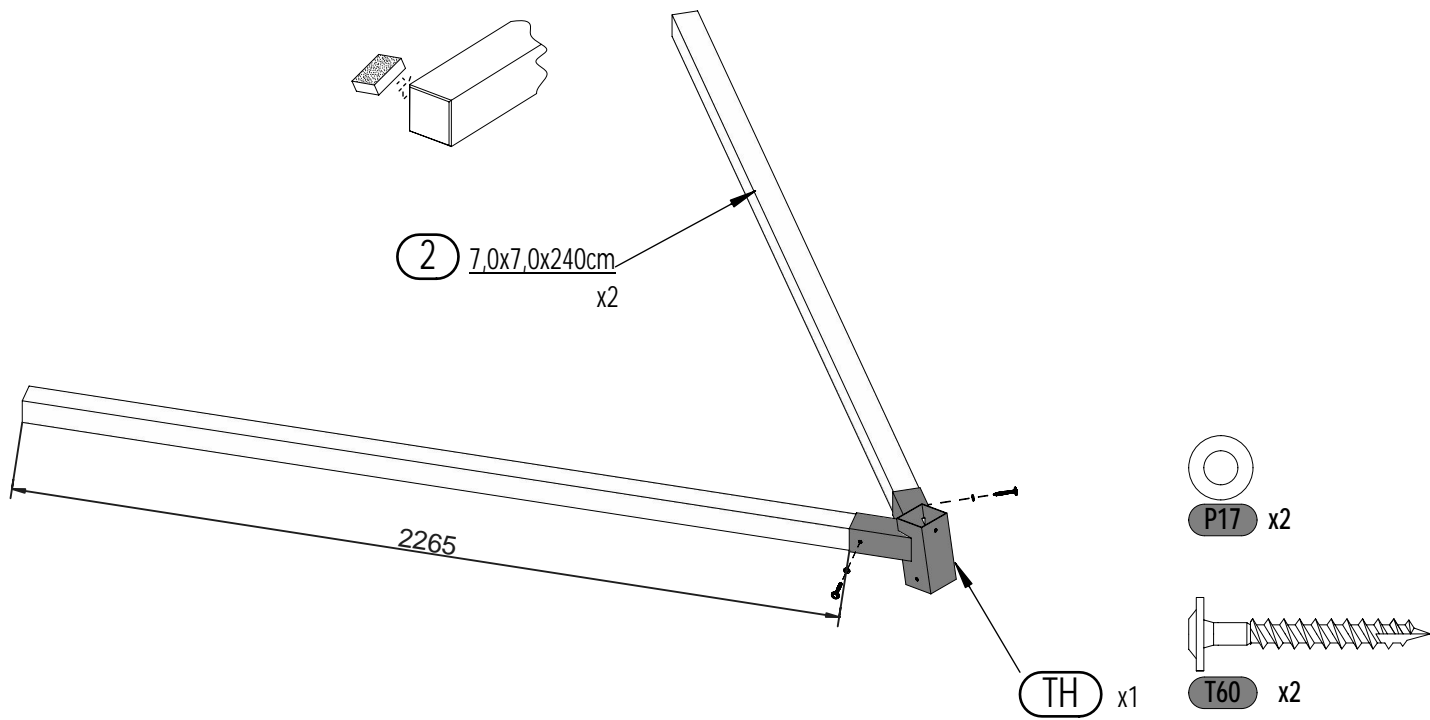

03

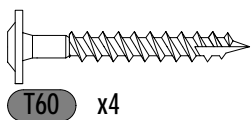
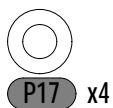
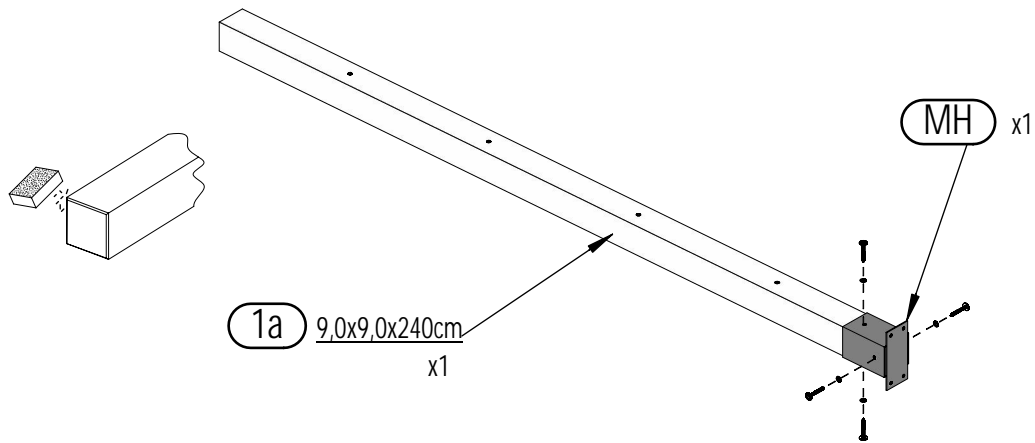

04

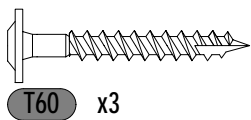
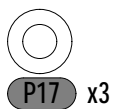
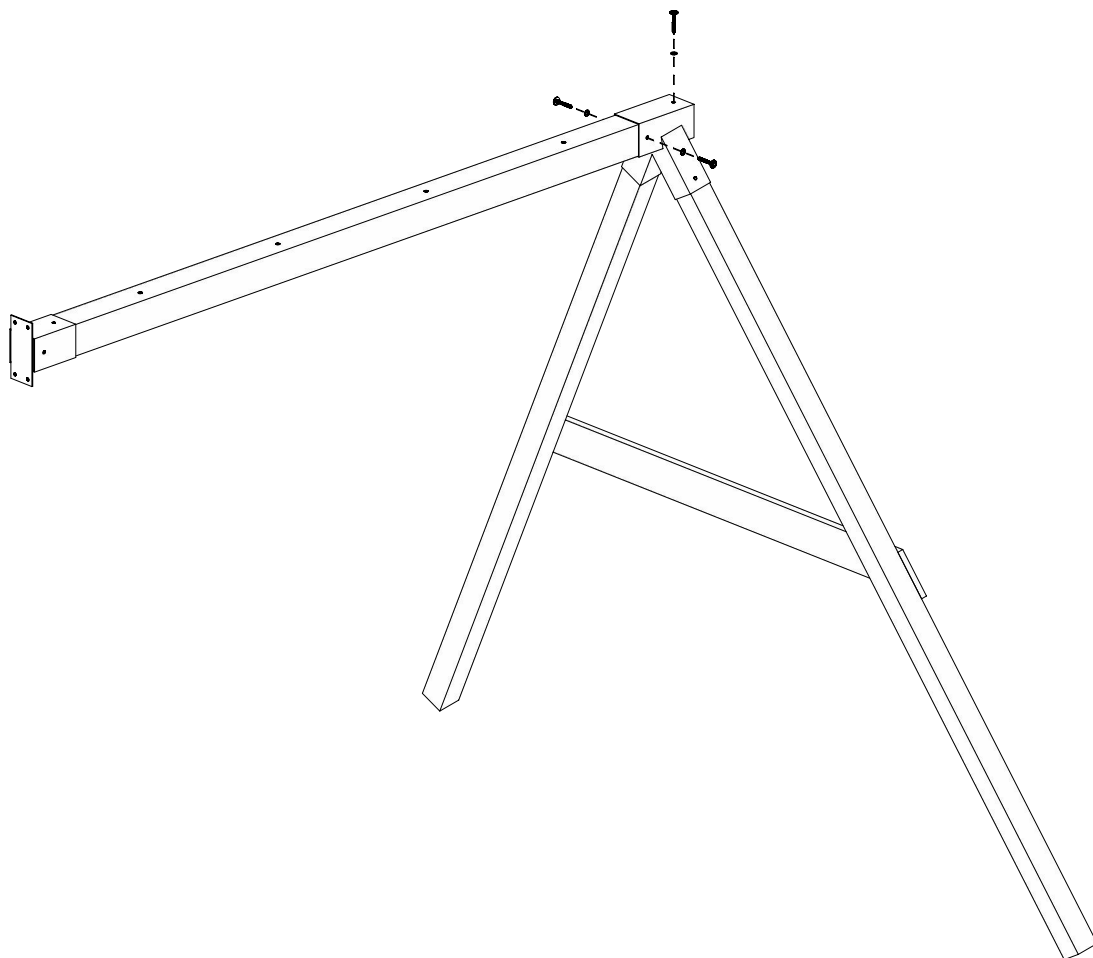

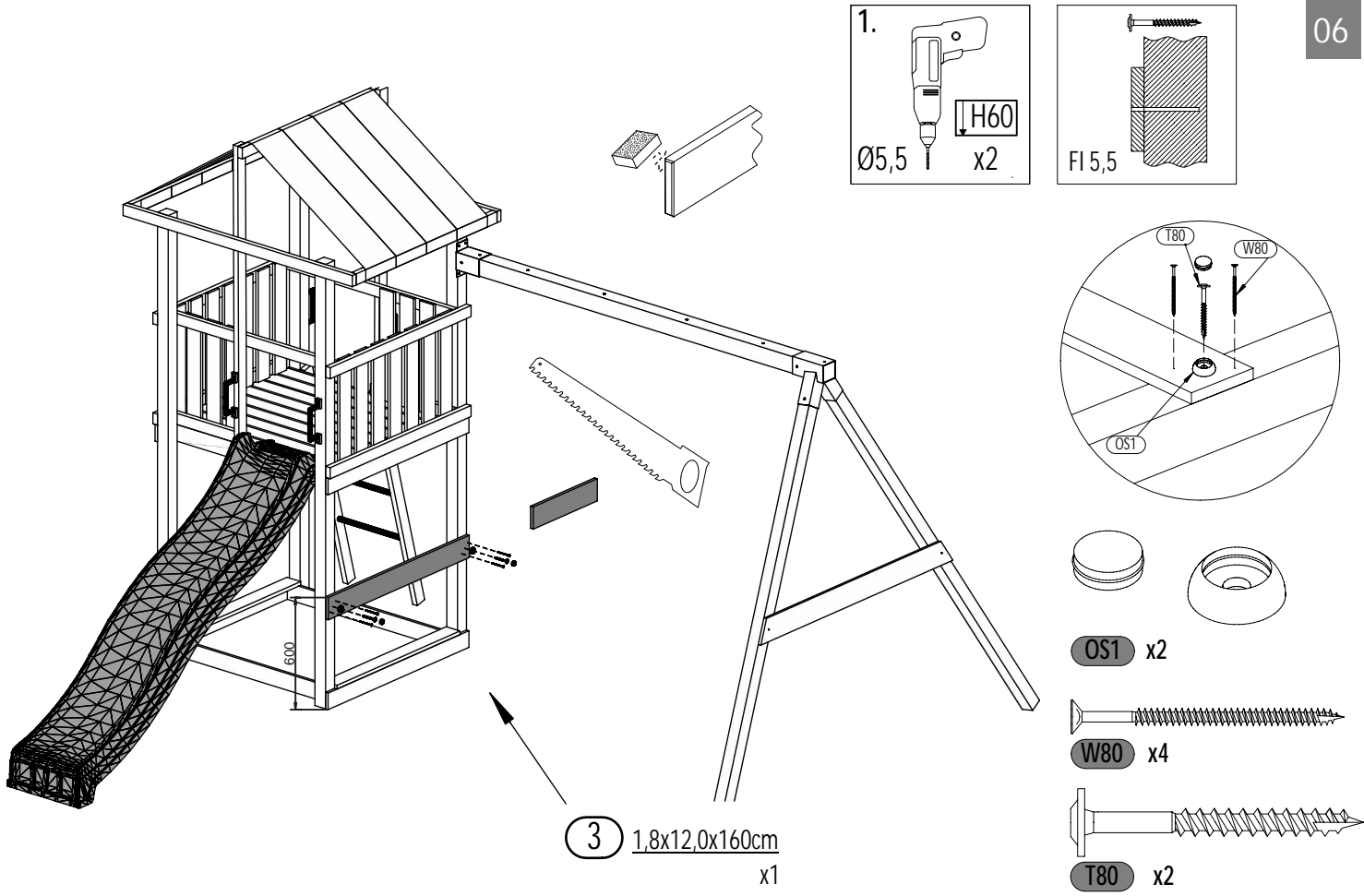
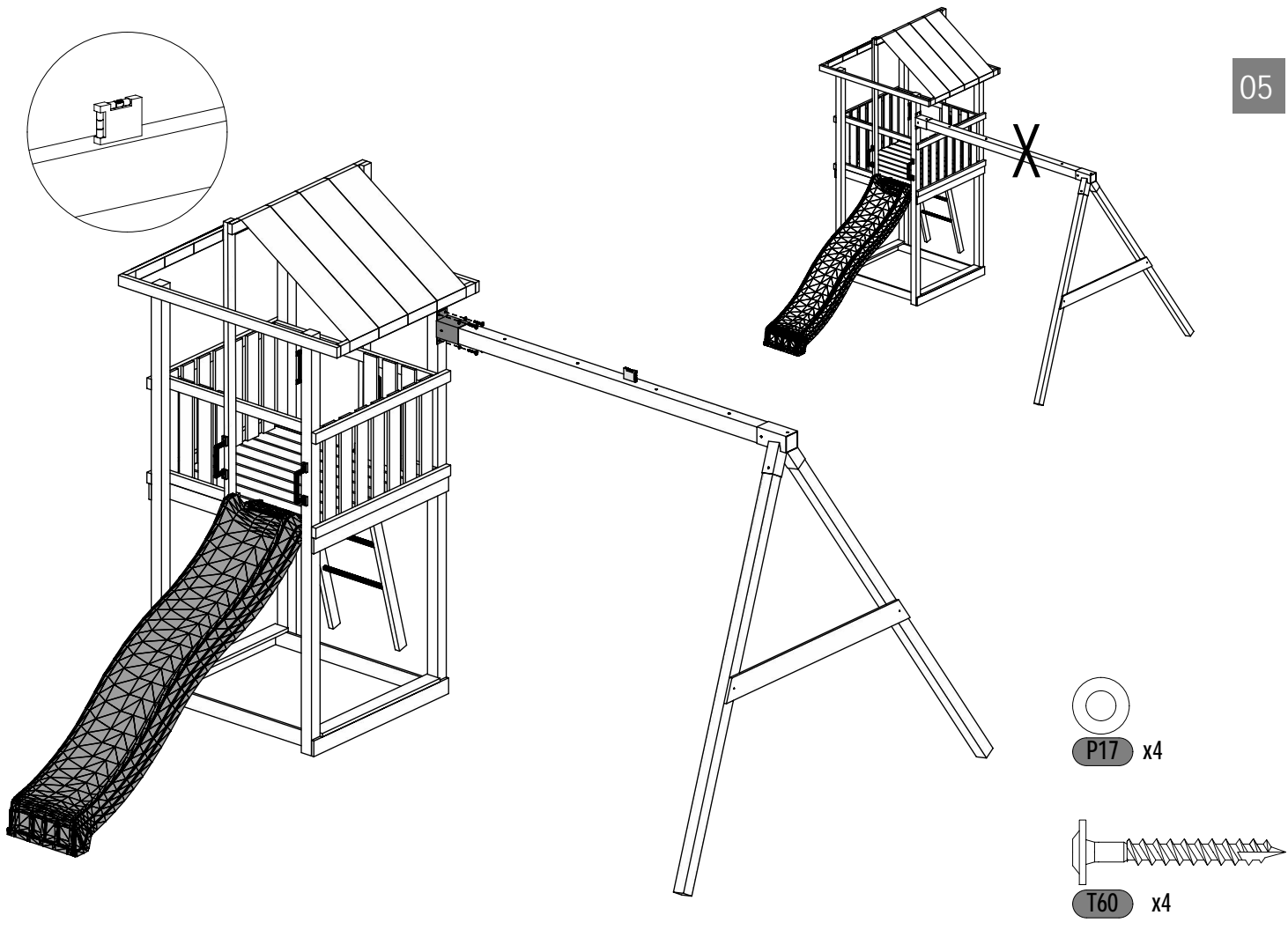

Zgodne z normą PN-EN 71 stosuj zalecenia producenta odnośnie odległości oraz metody mocowania poszczególnych elementów
 In compliance with the standard PN-EN 71, apply guidelines of the producer in relation to distances and methods of fastening individual elements

07

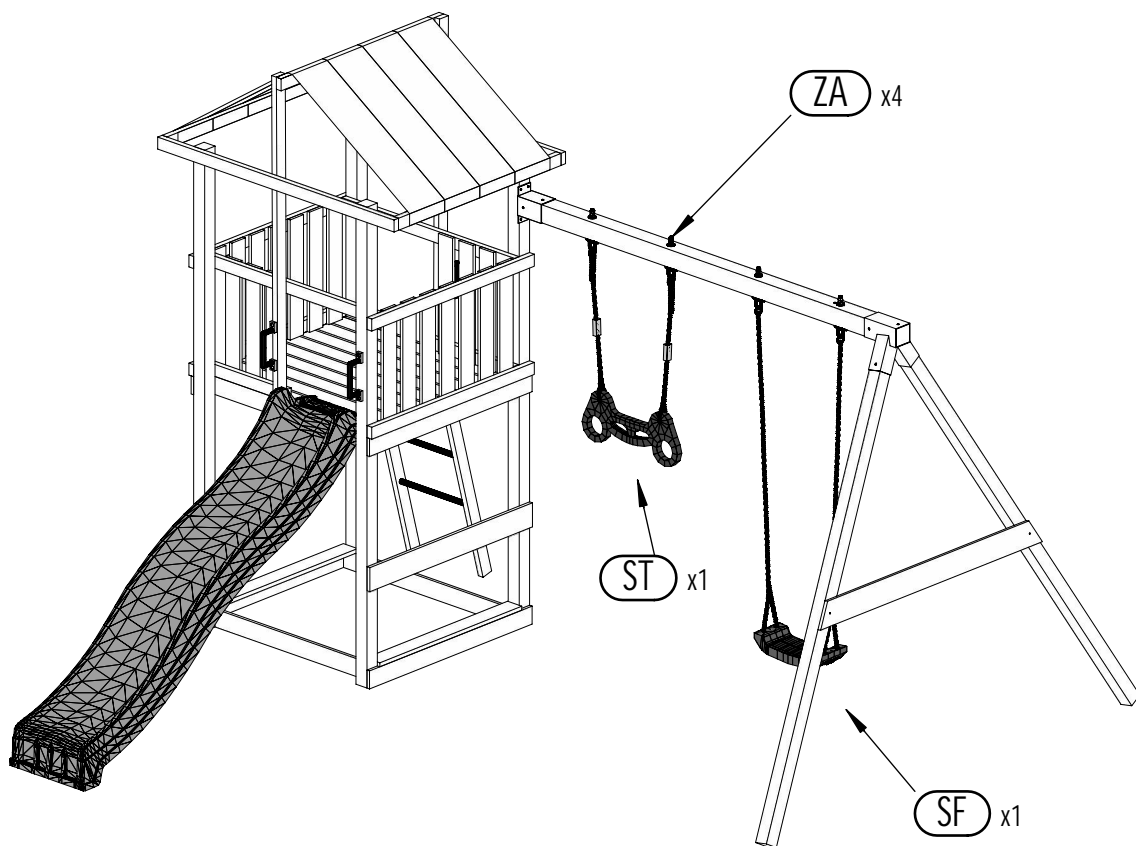

08

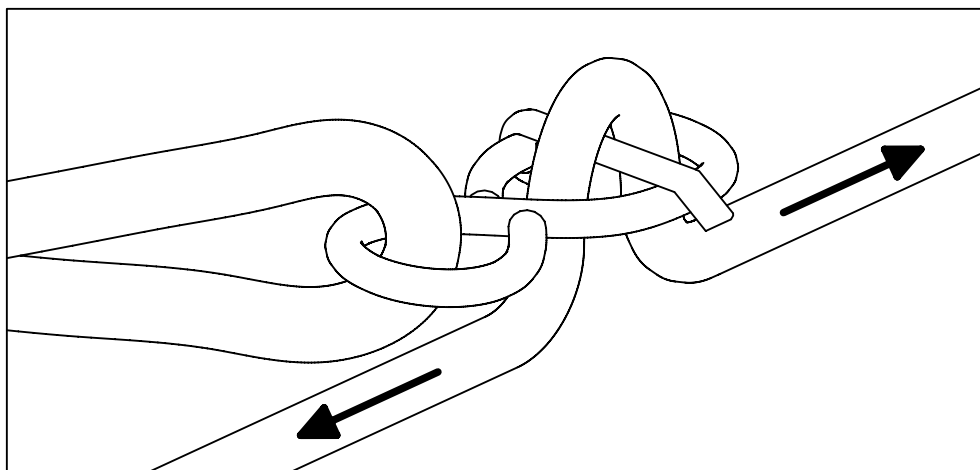

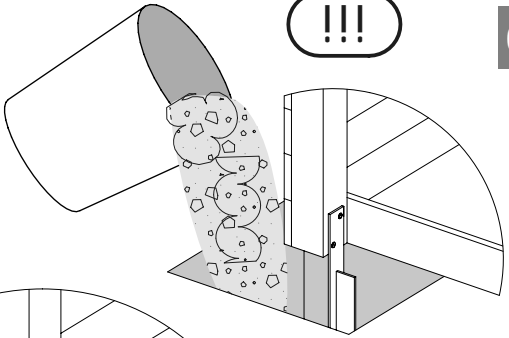
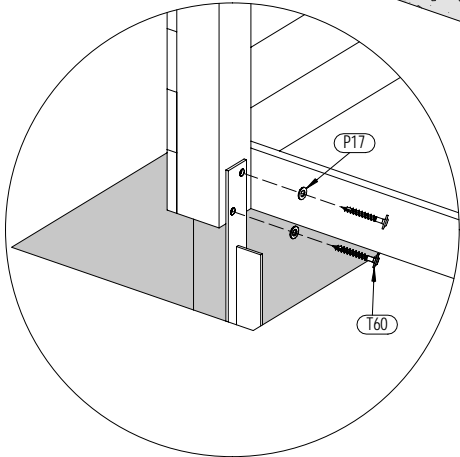
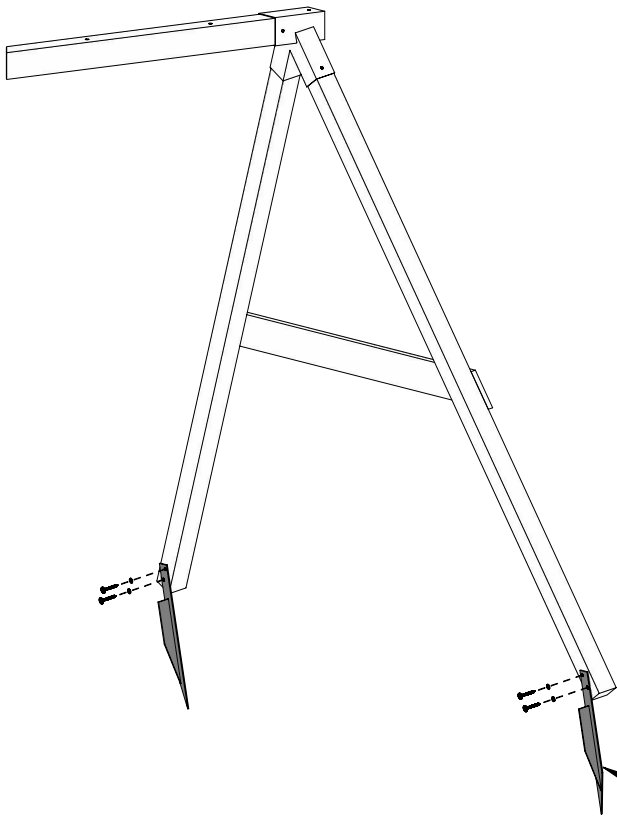

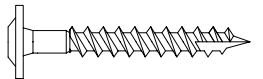

MG x2

 P17 x4

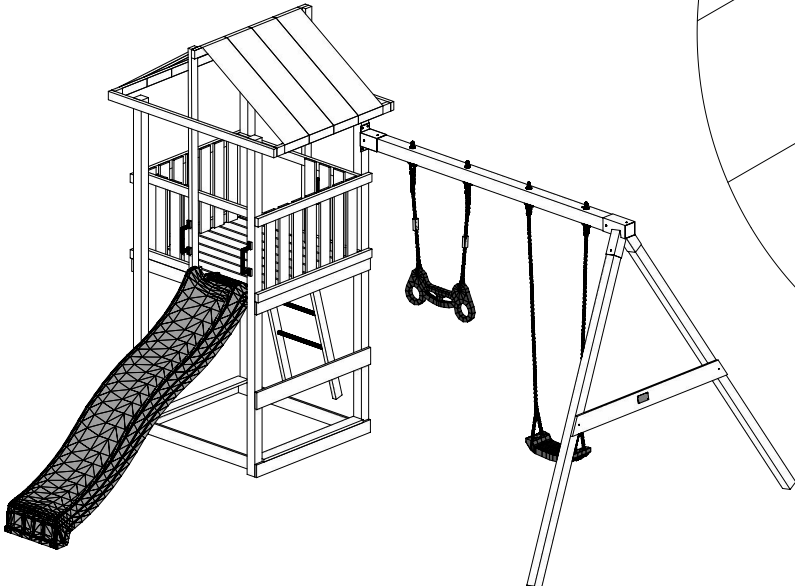
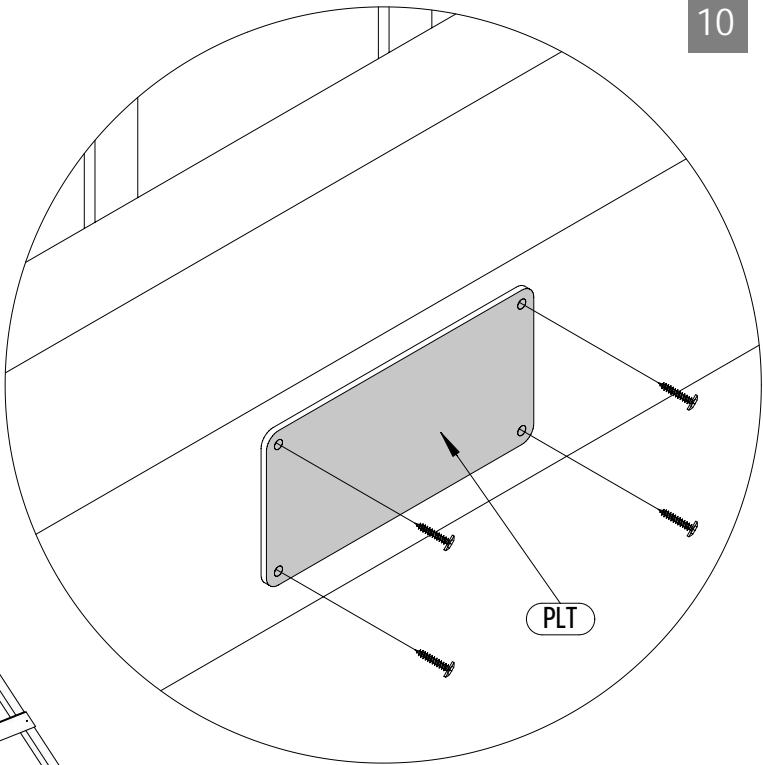
 T60 x4



PLT

 W20 x4

Zgodne z normą PN-EN 71 stosuj zalecenia producenta odnośnie odległości oraz metody mocowania poszczególnych elementów
In compliance with the standard PN-EN 71, apply guidelines of the producer in relation to distances and methods of fastening individual elements