

PLAYGROUND SPIELPLATZ

PLAC ZABAW AIRE DE JEUX

(385 x 373 x h313cm)

003_00925_27042021

GIANT

INSTALLATION INSTRUCTIONS
MONTAGEANLEITUNG

INSTRUKCJA MONTAŻU
GUIDE D'INSTALLATION

Warranty period - 2 years from purchase date

Garantiezeit - 2 Jahre ab Kaufdatum

Okres gwarancji - 2 lata od momentu zakupu towaru

Période de garantie - 2 ans à compter de l'achat

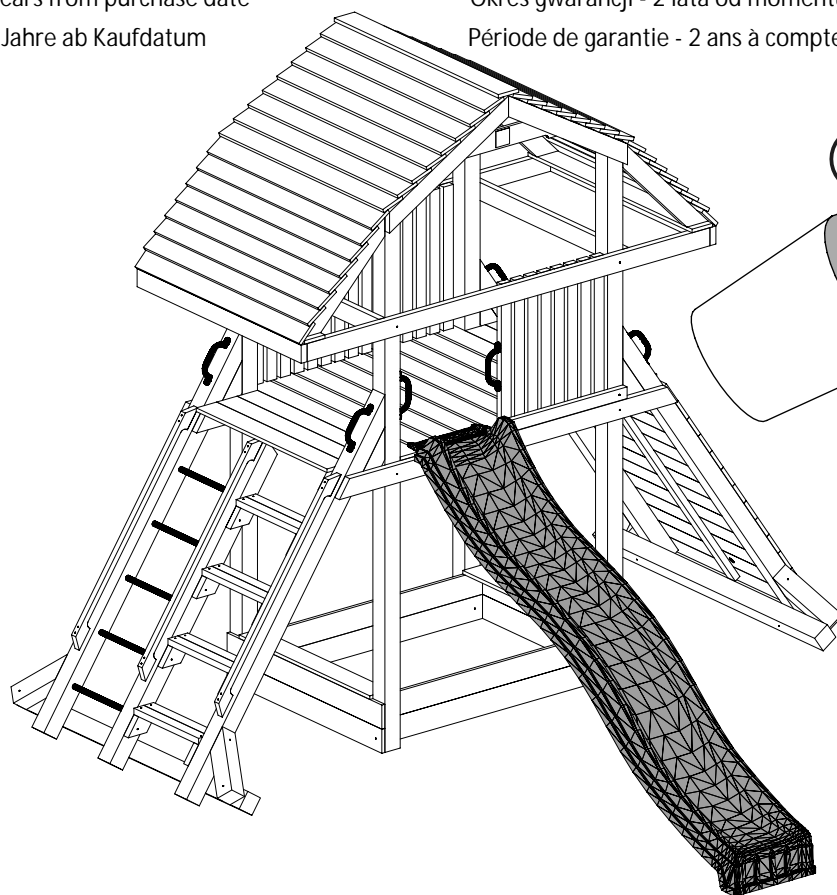

EN - 71

WARNINGS!

Only for home use.

Dedicated for external use only.

Not suitable for children under 3 years old.

Risk of falling down and/or hitting.

Maximum user weight is up to 50 kg.

Maximum number of users staying on the playground at the same time: 10.

OSTRZEŻENIA!

Tylko do użytku domowego.

Przeznaczony do użytku na zewnątrz.

Nie przeznaczony dla dzieci poniżej 3 roku życia.

Niebezpieczeństwo upadku i/lub uderzenia.

Maksymalna waga użytkownika to 50 kg.

Maksymalna liczba użytkowników przebywających na placu zabaw w tym samym czasie: 10.

ACHTUNG!

Nur für den privaten, häuslichen Bereich.

Ausschließlich für die Verwendung im Freien.

Nicht geeignet für Kinder unter 3 Jahren.

Stolper- und / oder Sturzgefahr

Höchstgewicht pro Einzelkind beträgt 50 kg

Der Aufenthalt auf diesem Spielturm ist max. : 10.

Kindern gleichzeitig erlaubt.

AVERTISSEMENT!

Aire exclusivement destinée à un usage privé.

Aire exclusivement destinée à un usage en extérieur.

Prévue pour les enfants de plus de 3 ans.

Danger de chute ou de choc.

Poids maximal d'un utilisateur : 50 kg.

Nombre maximal d'utilisateurs présents en même temps sur la même aire de jeux: 10.

W80 x189
+1 Gratis



P15 x32

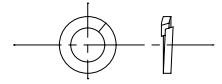

W50 x341
+3 Gratis



OS1 x54
+3 Gratis

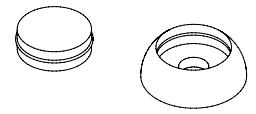

W30 x2

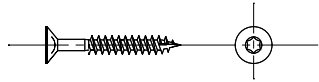

NS x1



W20 x14



T160 x17

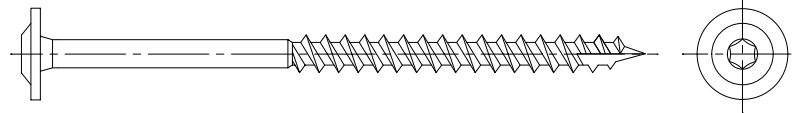

T120 x8

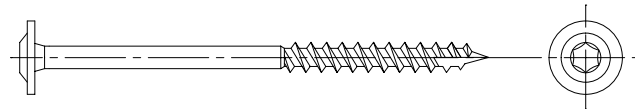

T80 x31

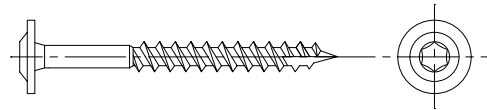

T60 x38

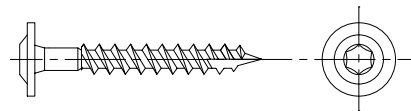

S40 x2

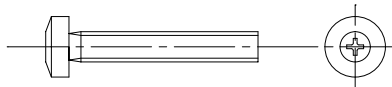

S30 x32

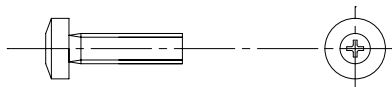

Ø3
00239
x1

Ø5,5
01372
x1

Ø10
00188
x1

L11 x33

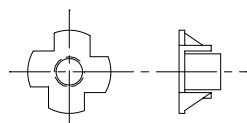

PH3
00068
x1

PZ2
00241
x1

TX25
00190
x1

TX30
00316
x1

TX40
00242
x1

P17 x11

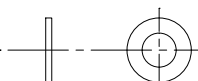

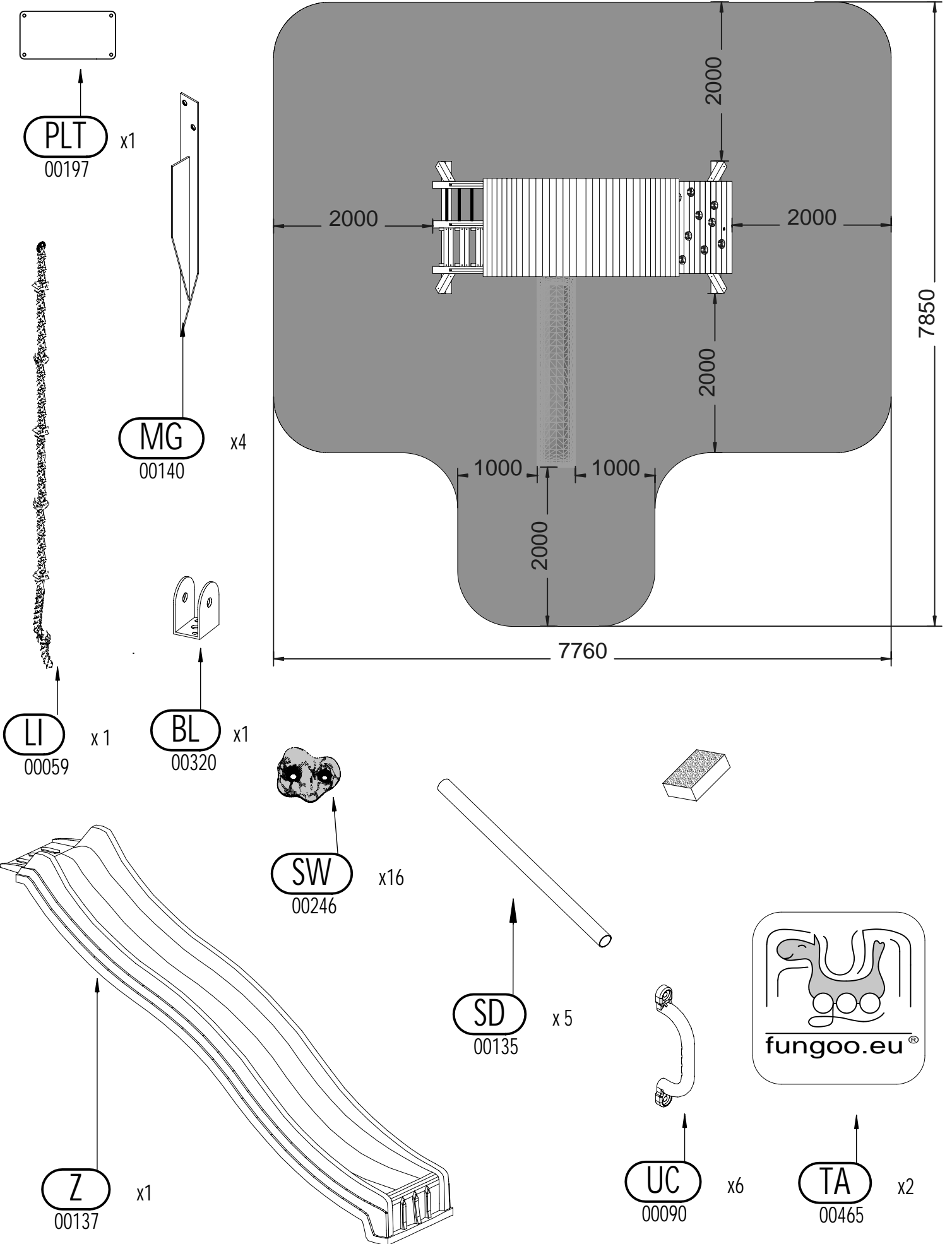

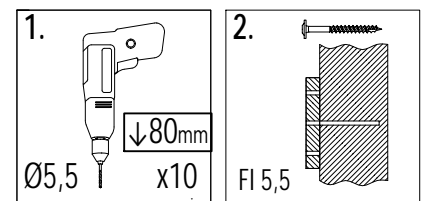
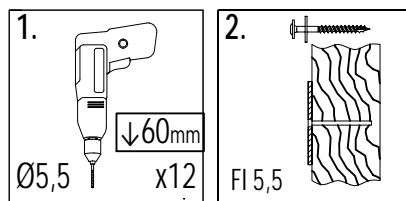
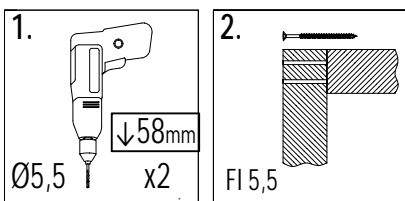
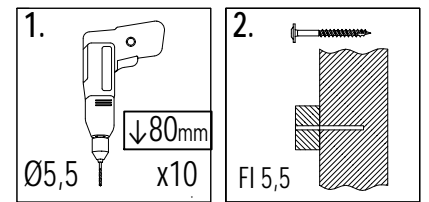
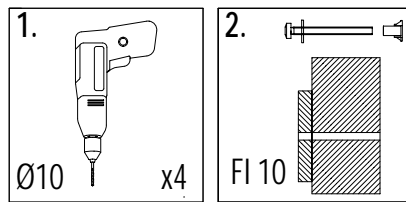
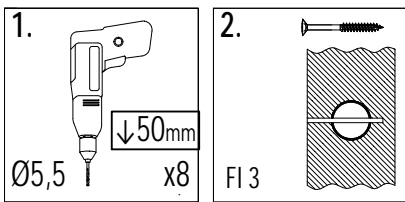
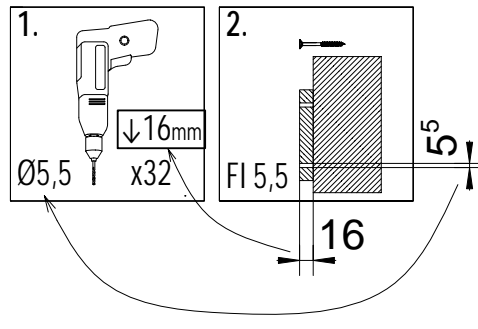
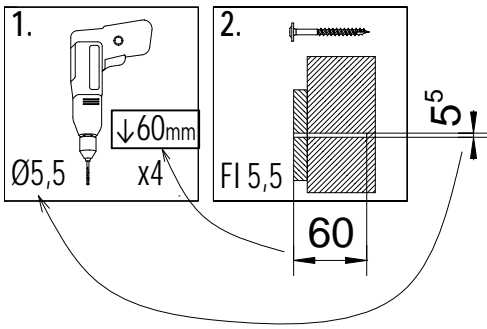
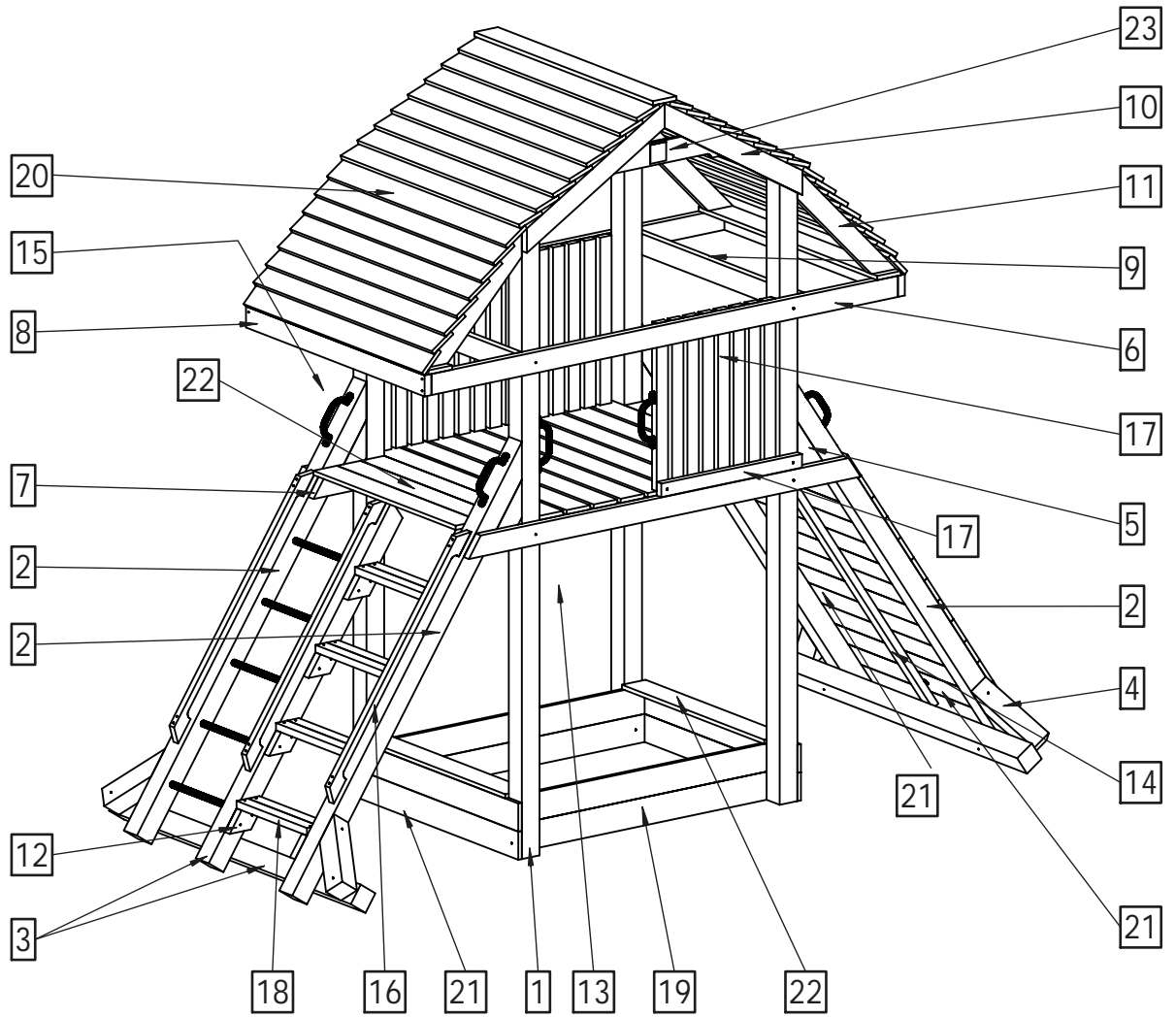

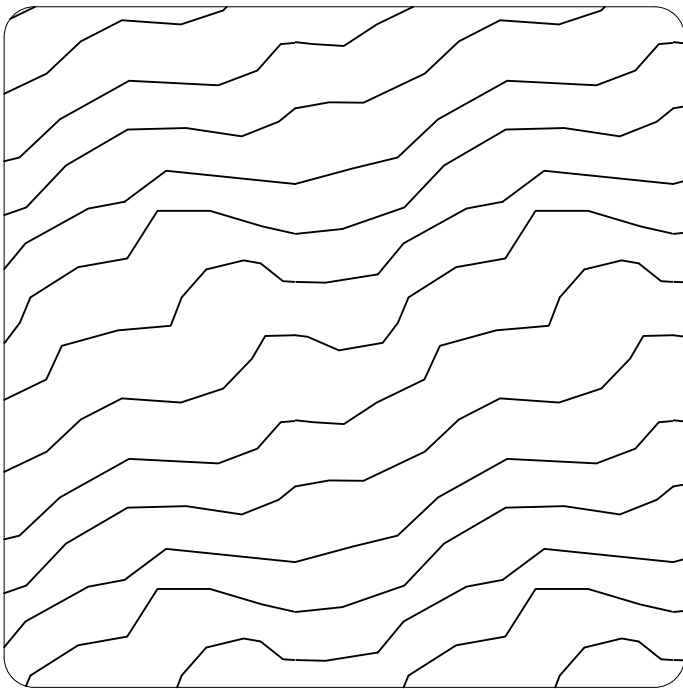

9 x 9 cm

Lp.	Kod	Wymiary [mm]	szk.
1	05713	90x90x2700mm	4
2a	00405	90x90x2085mm	3
2b	00407	90x90x2085mm	1
3a	00413	90x90x1665mm	1
3b	00415	90x90x1665mm	1
3c	00522	90x90x1665mm	1
4a	00417	90x90x350mm	4
5a	00401	90x90x270mm	4

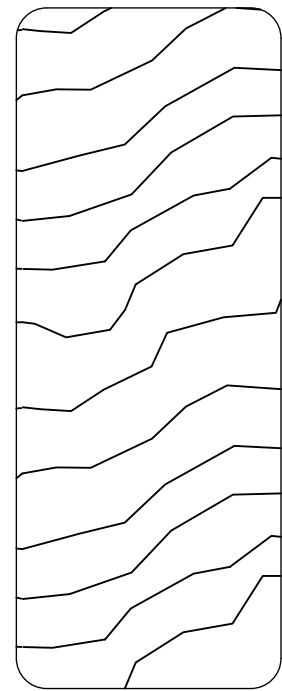

3,5 x 9,0 cm

Lp.	Kod	Wymiary [mm]	szk.
6a	06403	35x90x2370mm	2
7a	00421	35x90x1990mm	4
8a	00614	35x90x1230mm	2
9a	06405	35x90x1160mm	2
10a	00901	35x90x863mm	4
11a	02364	35x90x720mm	4
12a	02366	35x90x170mm	8

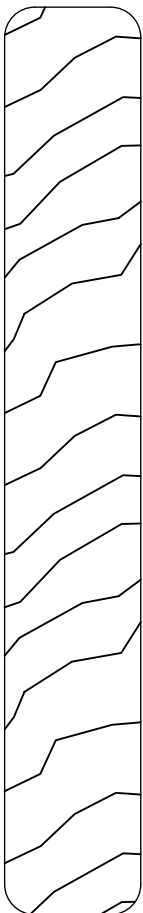

1,8 x 12,0 cm

Lp.	Kod	Wymiary [mm]	szk.
19	05774	18x120x1400mm	2
19a	06409	18x120x1400mm	2
20	01575	18x120x1230mm	35
21	00378	18x120x1160mm	24
21a	00445	18x120x1160mm	2
21b	00447	18x120x1160mm	1
22	00449	18x120x980mm	8
23a	06411	18x120x980mm	2

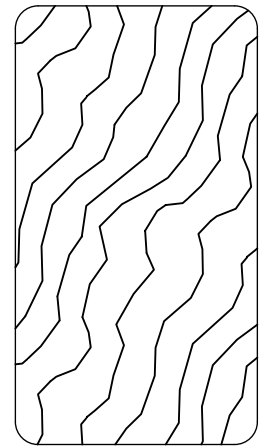

3,2 x 5,8 cm

Lp.	Kod	Wymiary [mm]	szk.
13a	06407	32x58x1895mm	1
14	05745	32x58x1600mm	1
15a	00903	32x58x1400mm	1
16a	01412	32x58x1250mm	3
17	01384	32x58x715mm	23
17a	00931	32x58x715mm	1
18a	00441	32x58x485mm	4
18b	00933	32x58x485mm	4

1

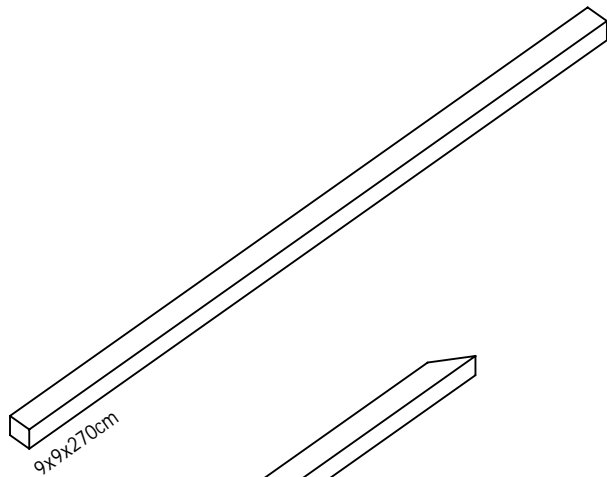

9x9x270cm

2a

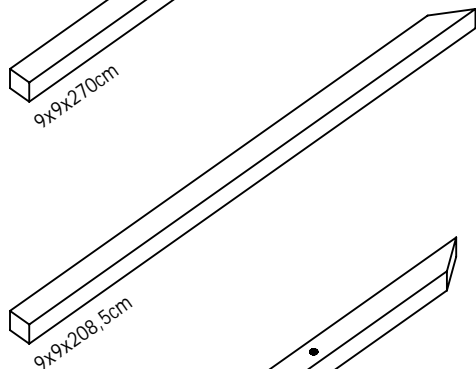

9x9x208,5cm

2b

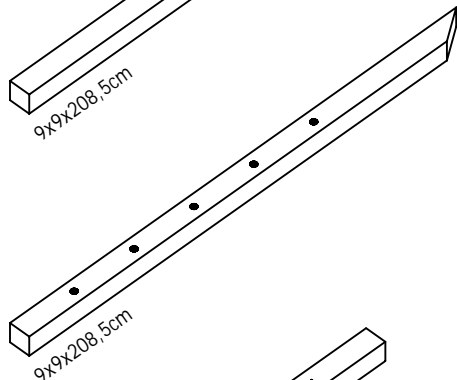

9x9x208,5cm

3a

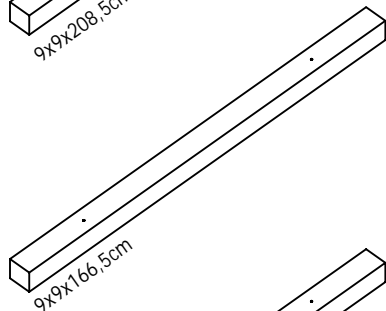

9x9x166,5cm

3b

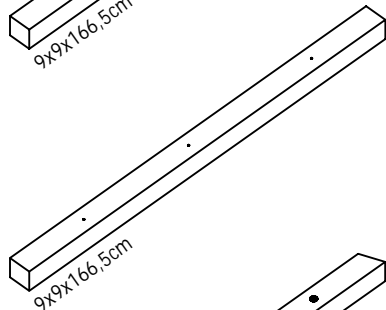

9x9x166,5cm

3c

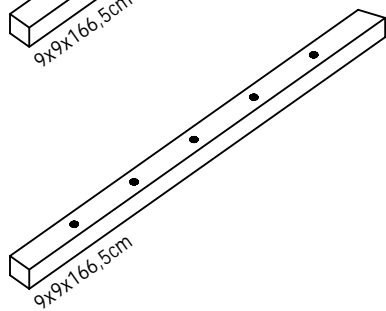

9x9x166,5cm

4a

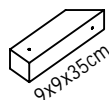

9x9x35cm

5a

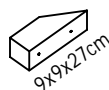

9x9x27cm

6a

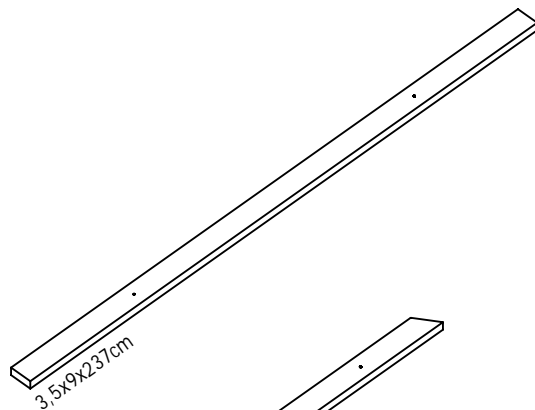

3,5x9x237cm

7a

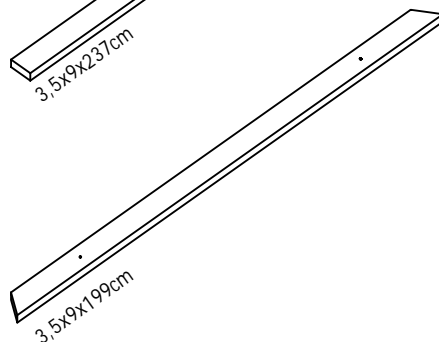

3,5x9x199cm

8a

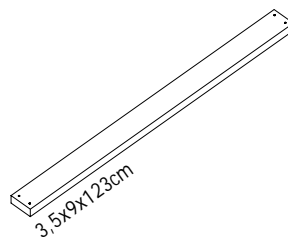

3,5x9x123cm

9a

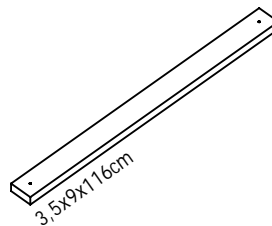

3,5x9x116cm

10a

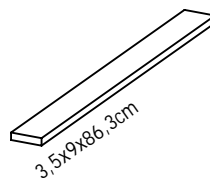

3,5x9x86,3cm

11a

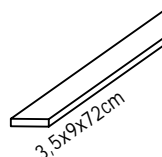

3,5x9x72cm

12a

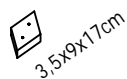

3,5x9x17cm

13a

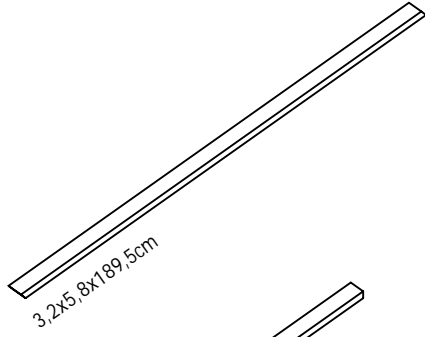

3,2x5,8x189,5cm

14

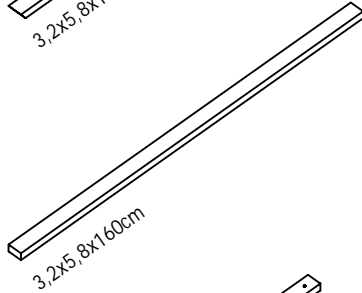

3,2x5,8x160cm

15a

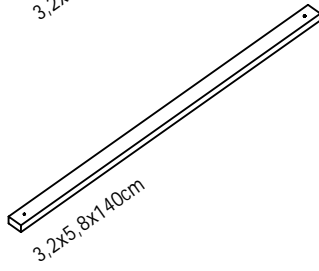

3,2x5,8x140cm

16a

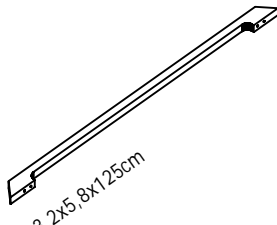

3,2x5,8x125cm

17

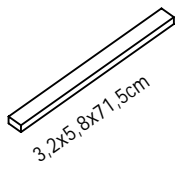

3,2x5,8x71,5cm

17a

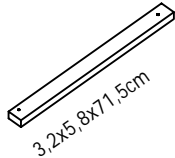

3,2x5,8x71,5cm

18a

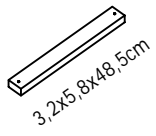

3,2x5,8x48,5cm

18b

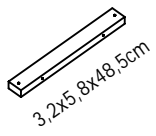

3,2x5,8x48,5cm

19

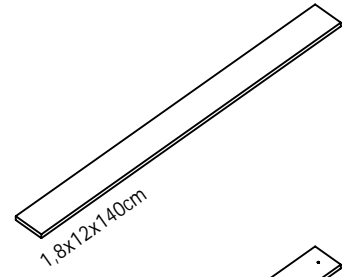

1,8x12x140cm

19a

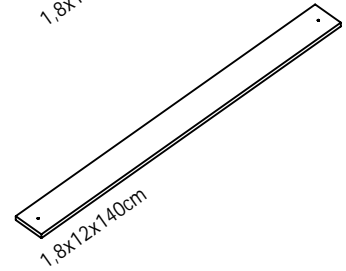

1,8x12x140cm

20

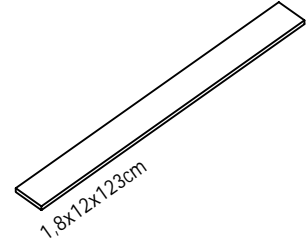

1,8x12x123cm

21

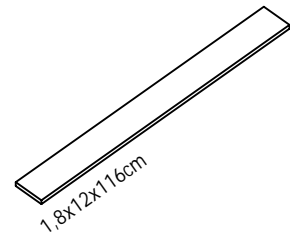

1,8x12x116cm

21a

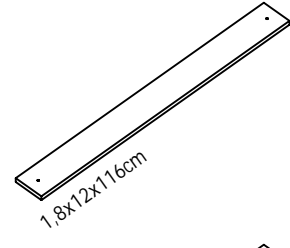

1,8x12x116cm

21b

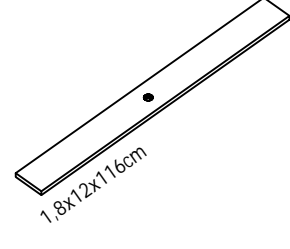

1,8x12x116cm

22

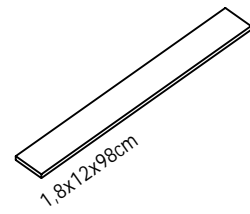

1,8x12x98cm

23a

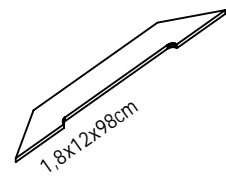

1,8x12x98cm

01

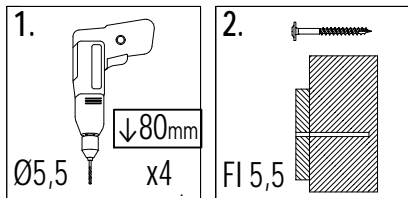

!!! x2

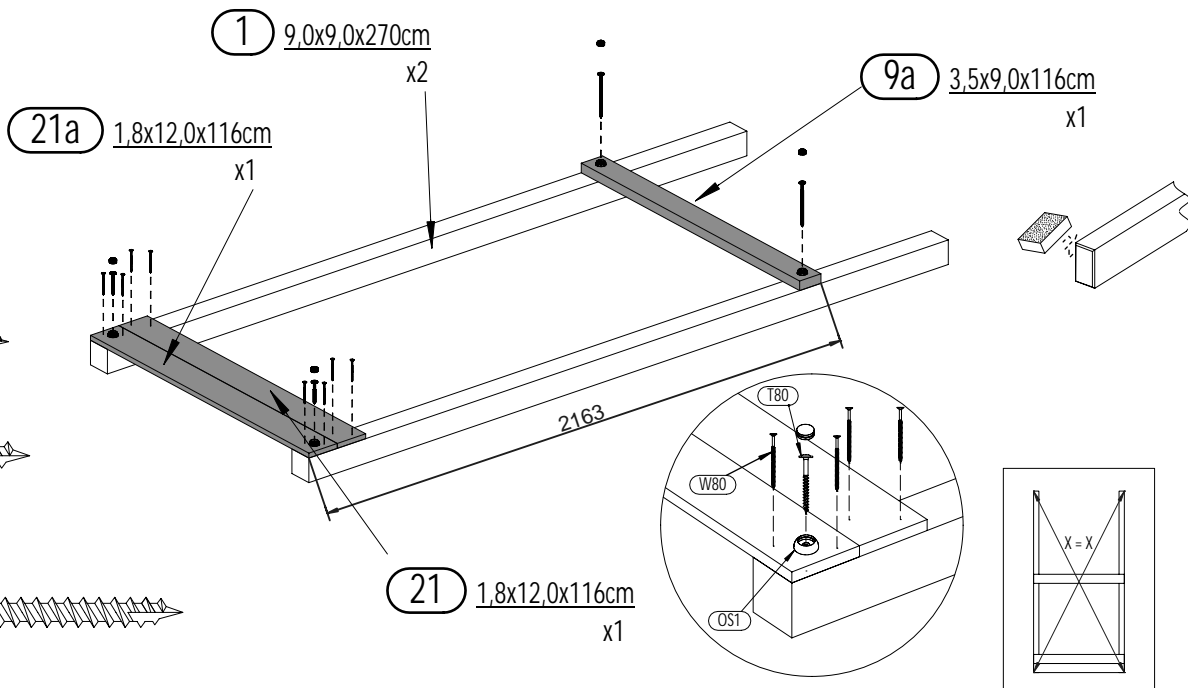
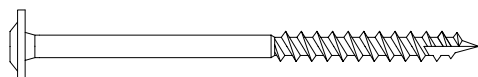
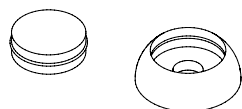
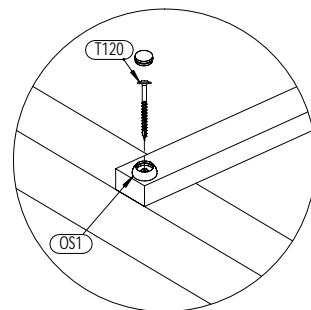

02

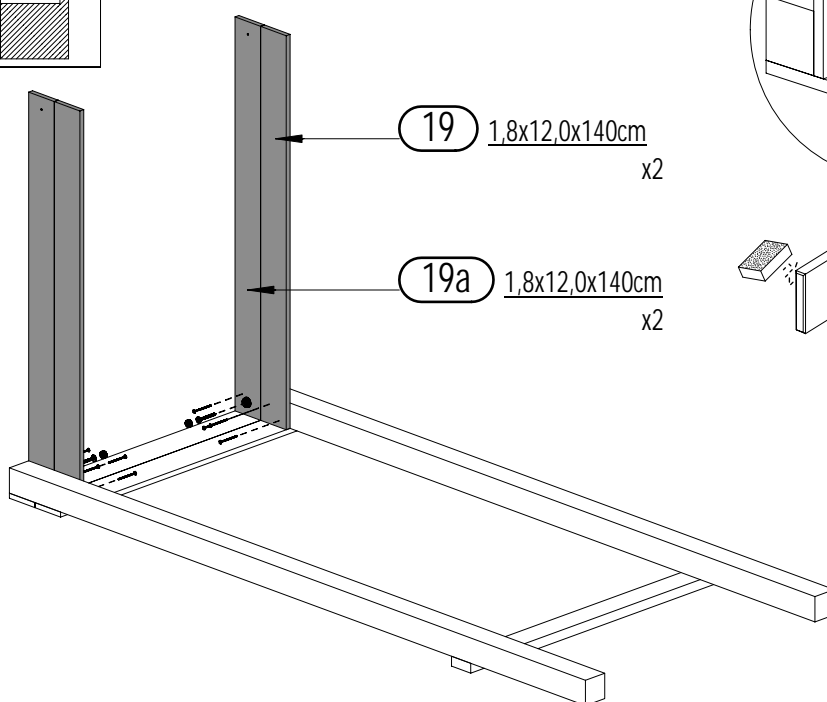
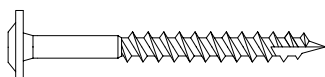
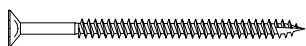
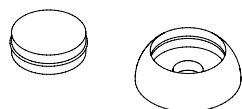
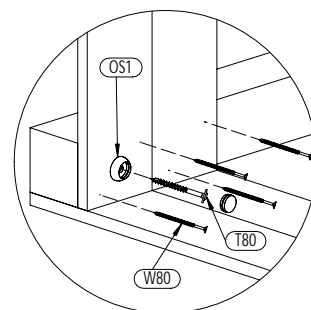
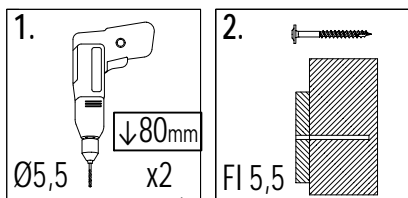

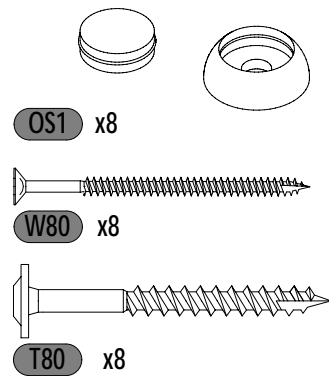
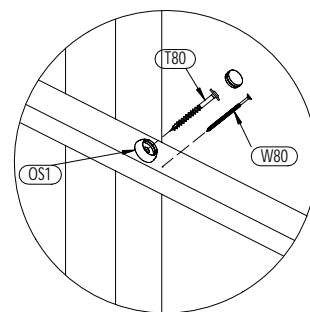
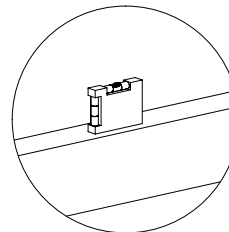
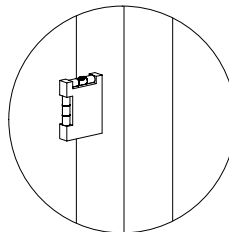
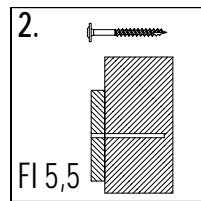
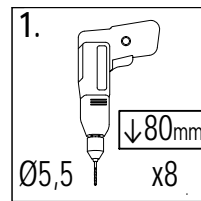
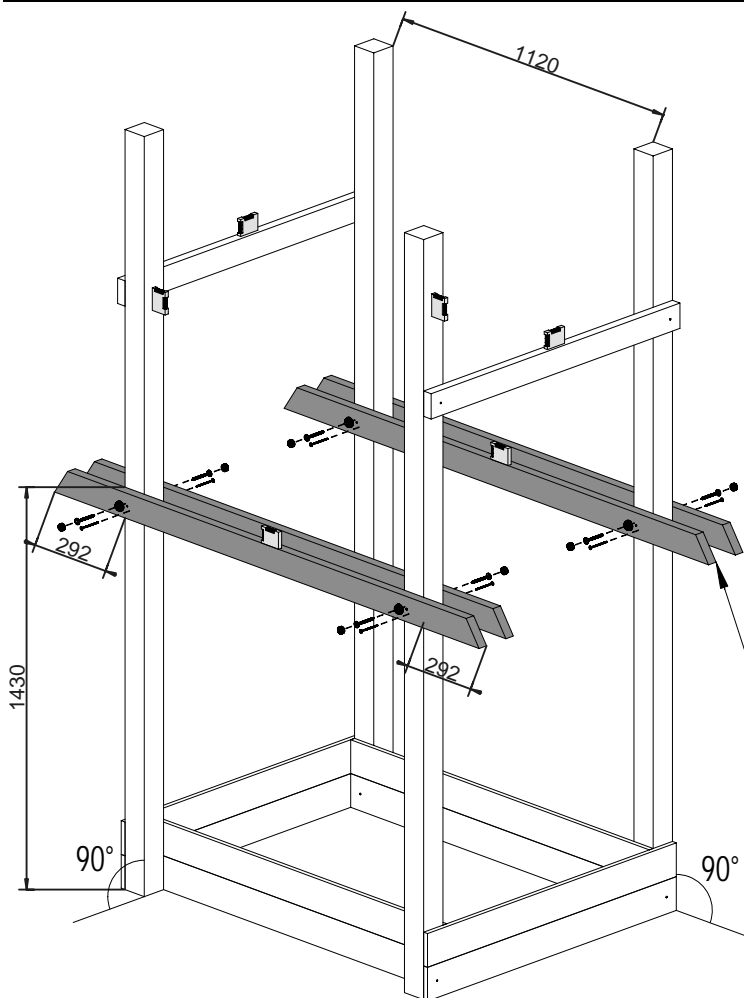
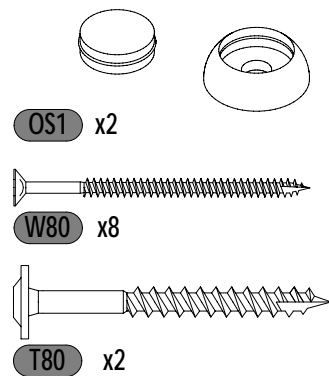
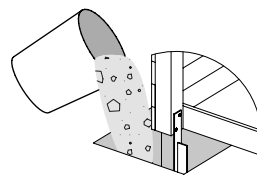
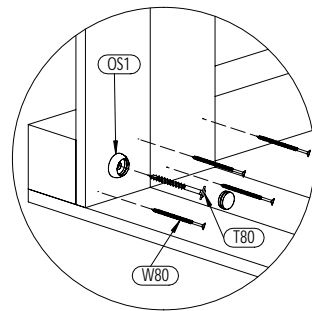
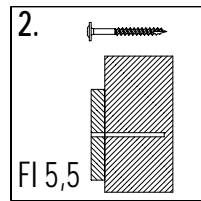
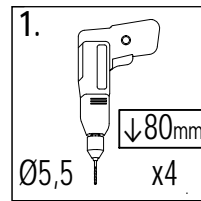
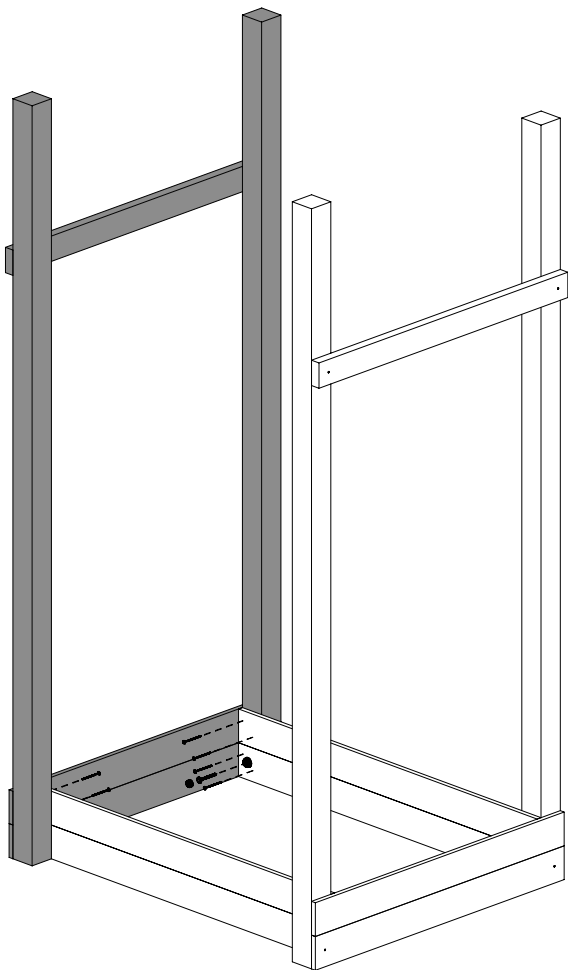

7a 3,5x9,0x199cm x4

21 1,8x12,0x116cm

05

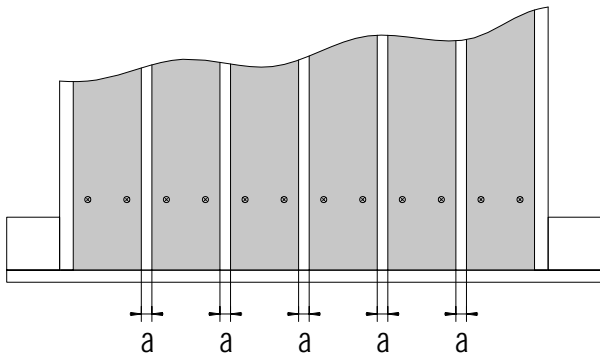
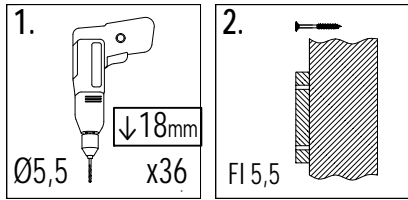

!!!min 13mm < a < !!!max 16mm

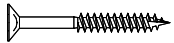
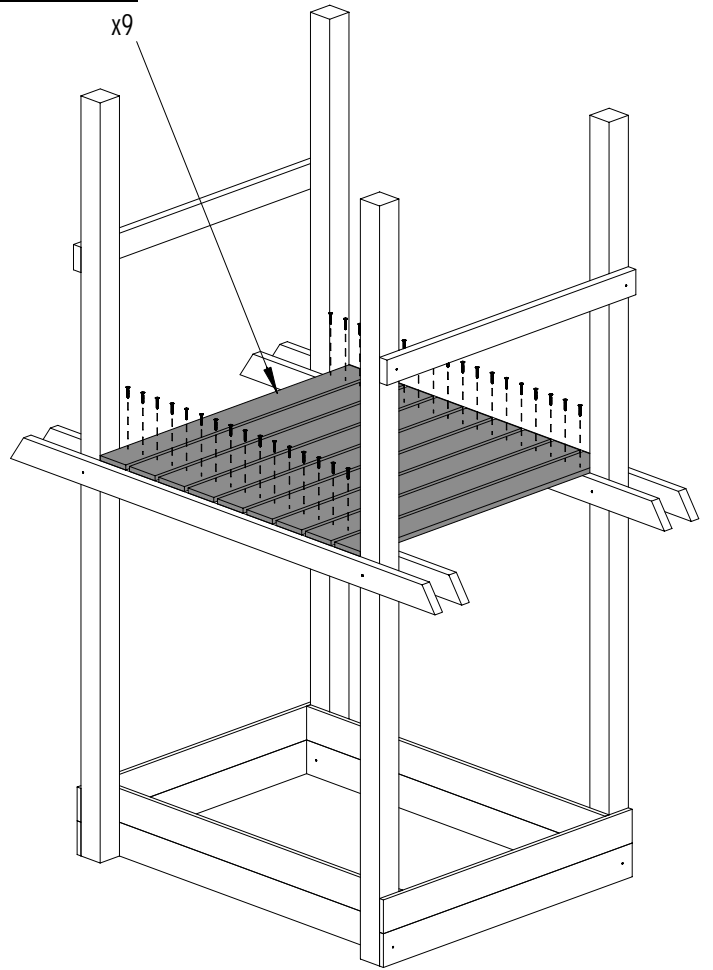

W50 x36

06

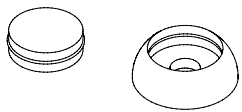
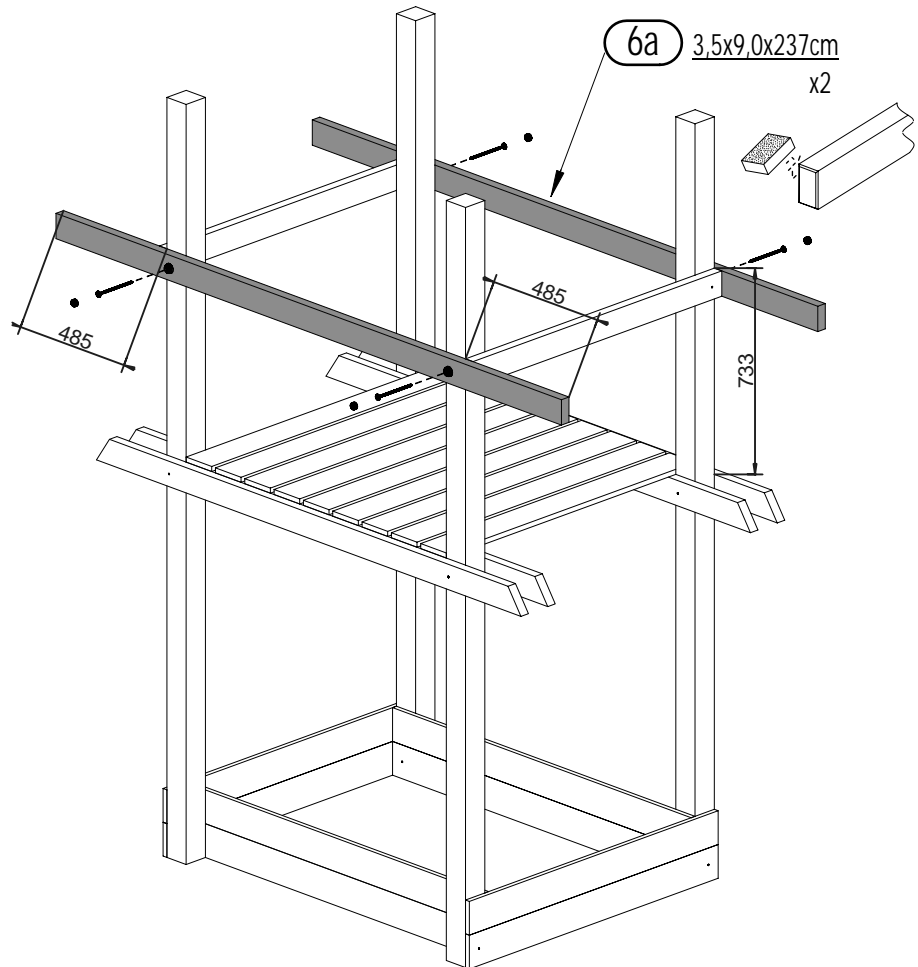
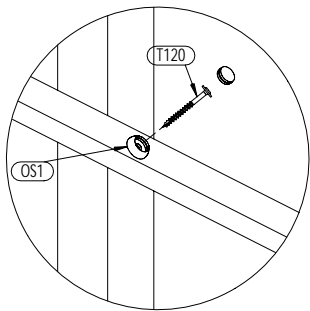
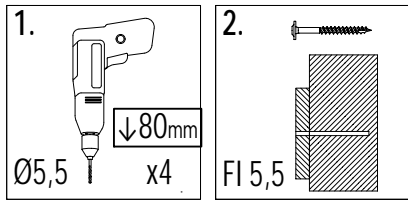

OS1 x4

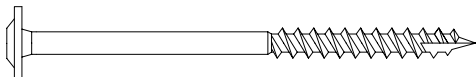

T120 x4

10 GIANT

Zgodnie z normą PN-EN 71 stosuj zalecenia producenta odnośnie odległości oraz metody mocowania poszczególnych elementów
In compliance with the standard PN-EN 71, apply guidelines of the producer in relation to distances and methods of fastening individual elements

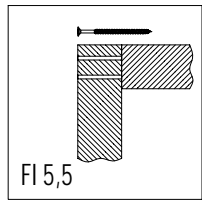
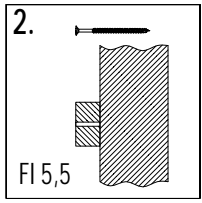
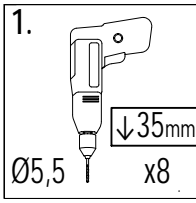
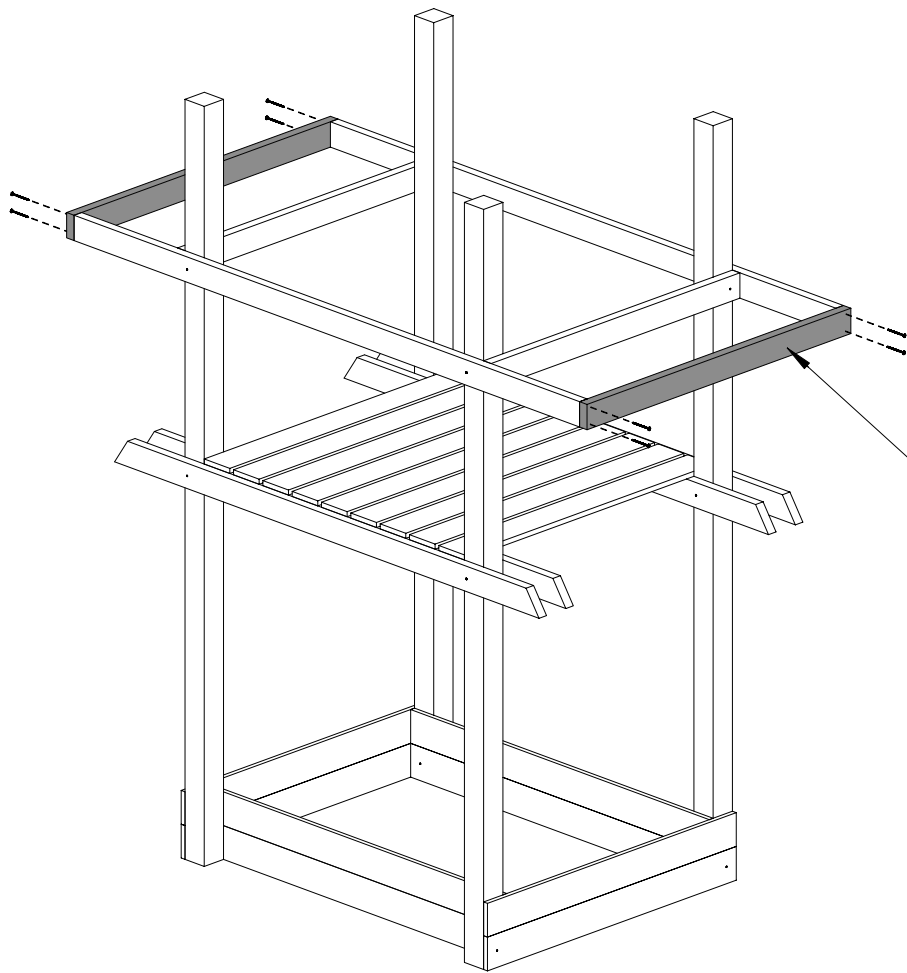

8a $3,5 \times 9,0 \times 123\text{cm}$
x2

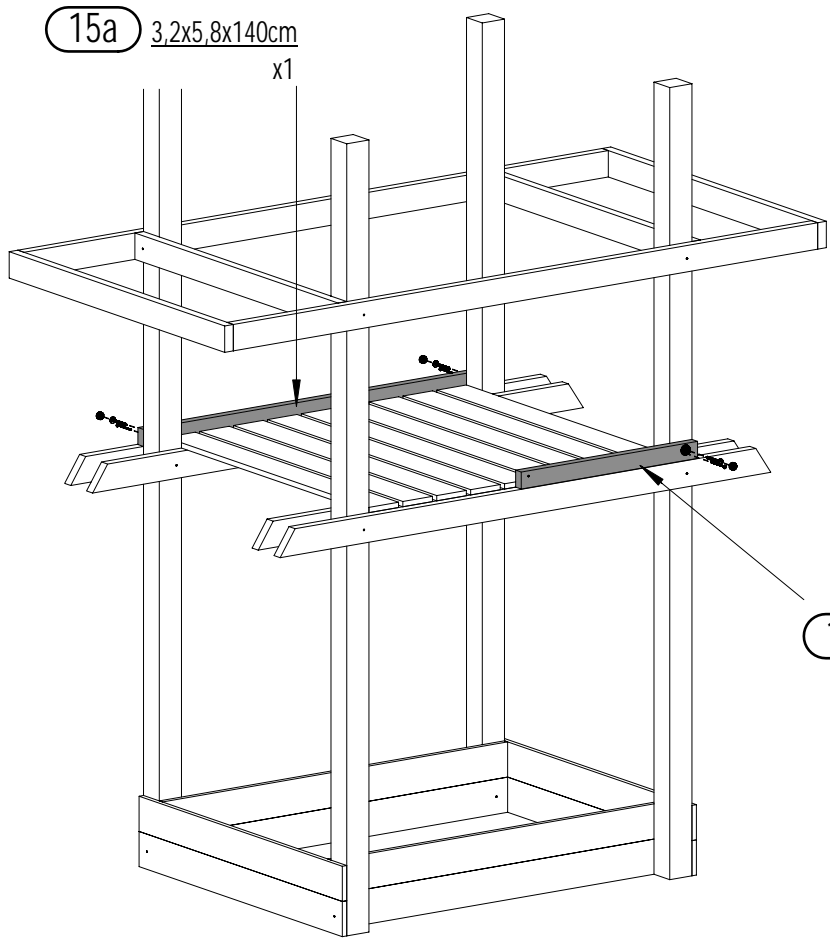
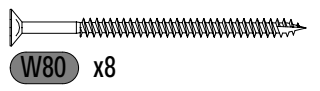

15a $3,2 \times 5,8 \times 140\text{cm}$
x1

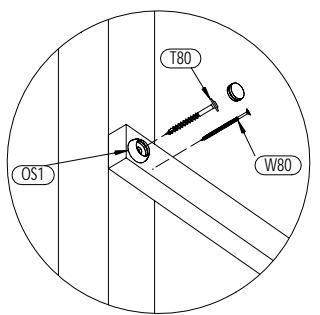
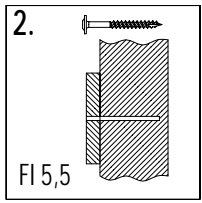
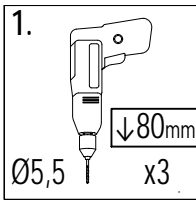

17a $3,2 \times 5,8 \times 71,5\text{cm}$
x1

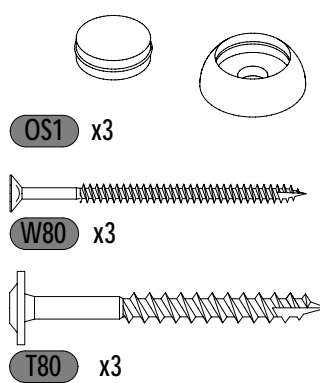

Zgodne z normą PN-EN 71 stosuj zalecenia producenta odnośnie odległości oraz metody mocowania poszczególnych elementów
 In compliance with the standard PN-EN 71, apply guidelines of the producer in relation to distances and methods of fastening individual elements

09

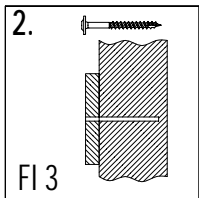
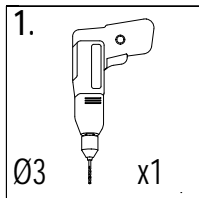

17 3,2x5,8x71,5cm

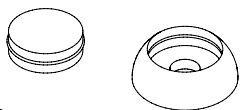
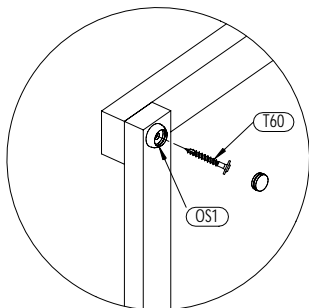
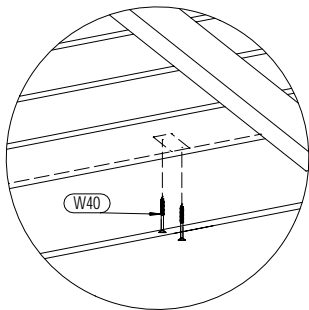
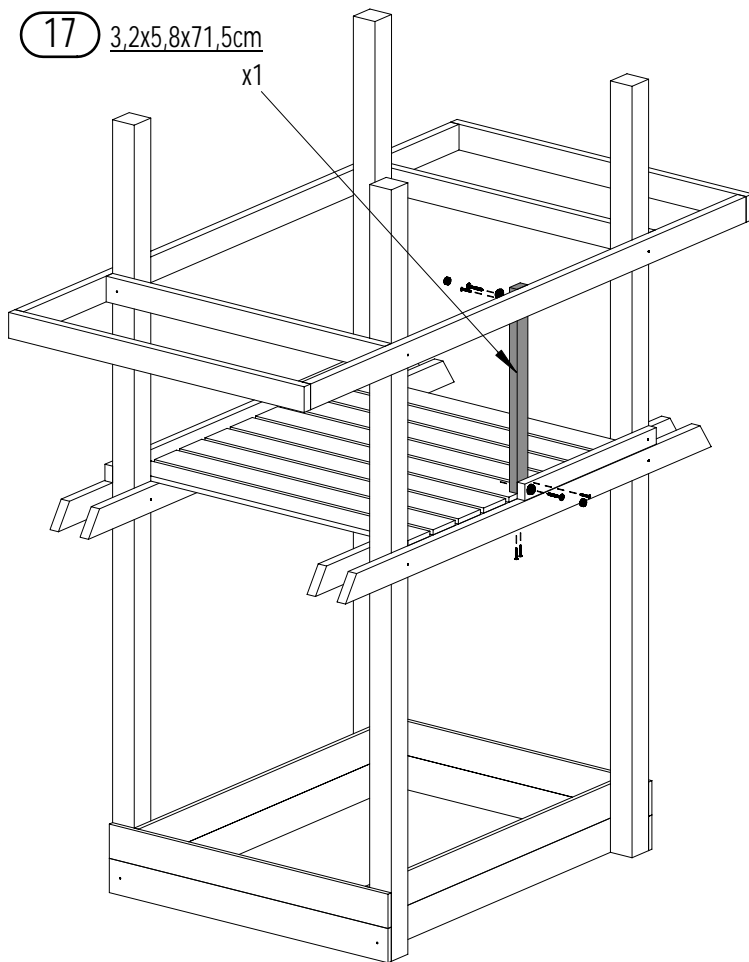

OS1 x2

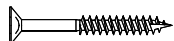

W50 x4

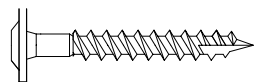

T60 x2

10

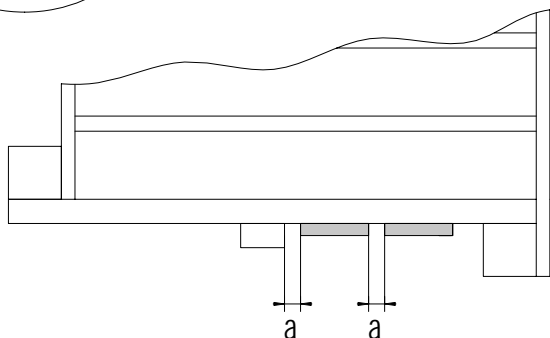
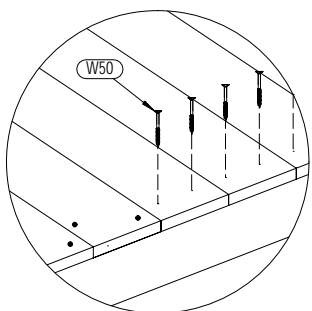
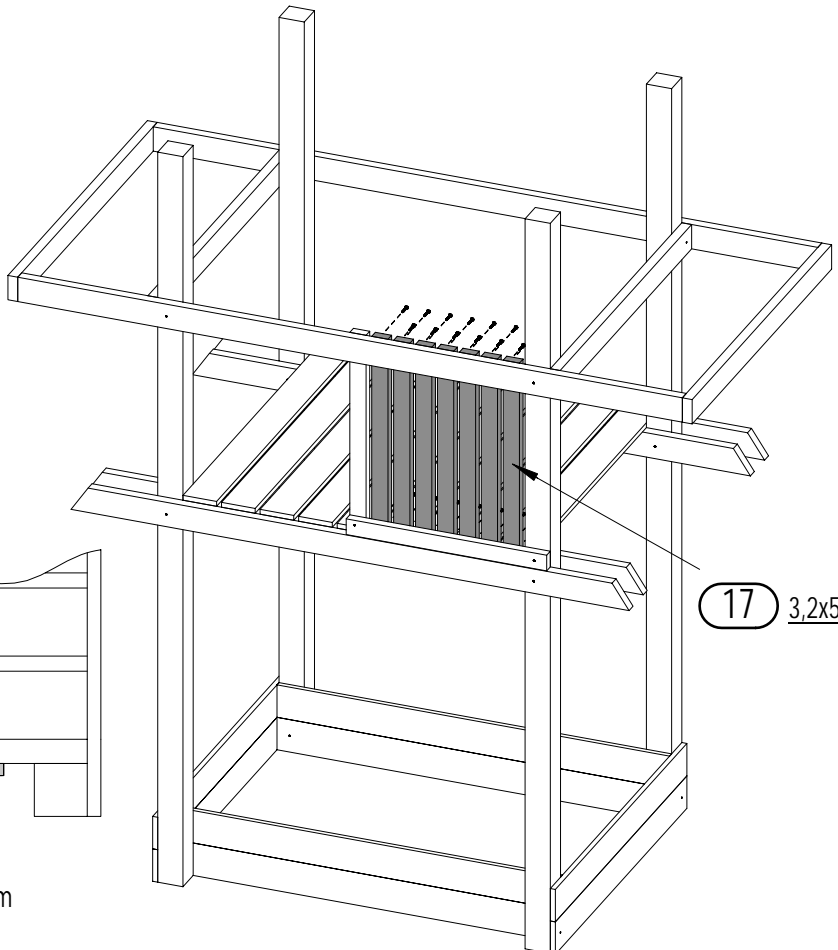
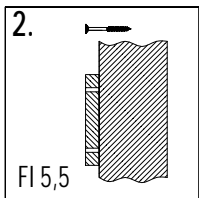
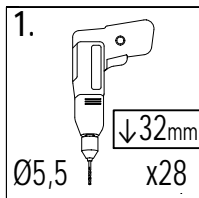

!!!min 13mm < a <!!!max 20mm

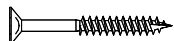

W50 x28

17 3,2x5,8x71,5cm x7

12

GIANT

Zgodne z normą PN-EN 71 stosuj zalecenia producenta odnośnie odległości oraz metody mocowania poszczególnych elementów
In compliance with the standard PN-EN 71, apply guidelines of the producer in relation to distances and methods of fastening individual elements

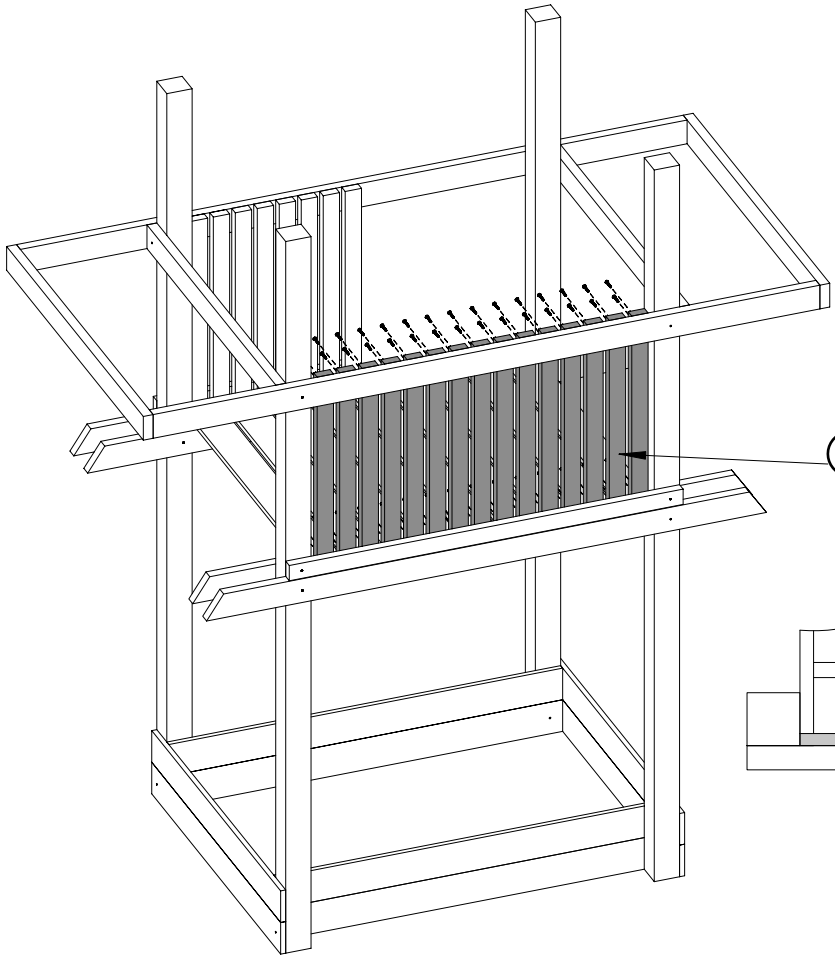
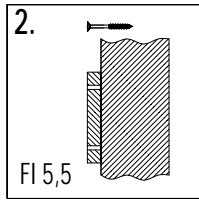
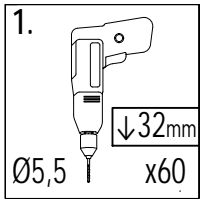

17 3,2x5,8x71,5cm
x15

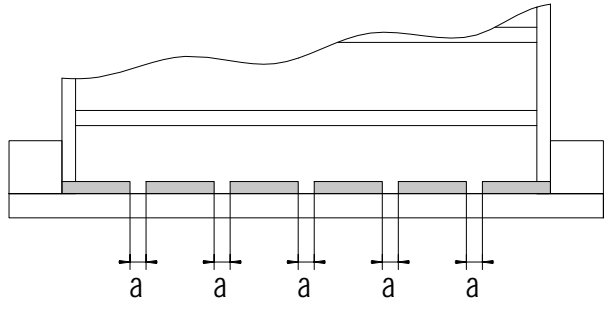
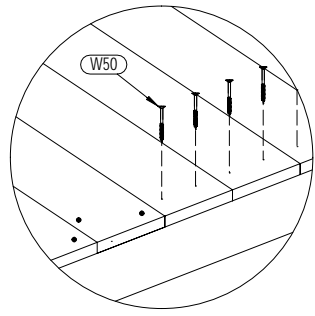

!!!min 13mm < a < !!!max 23mm

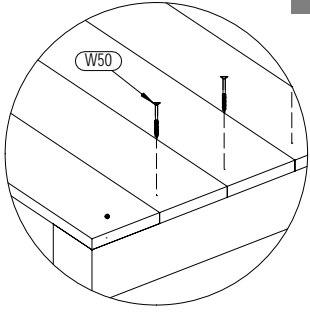
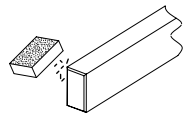
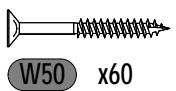

13a 3,2x5,8x189,5cm
x1

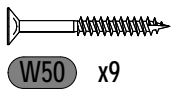
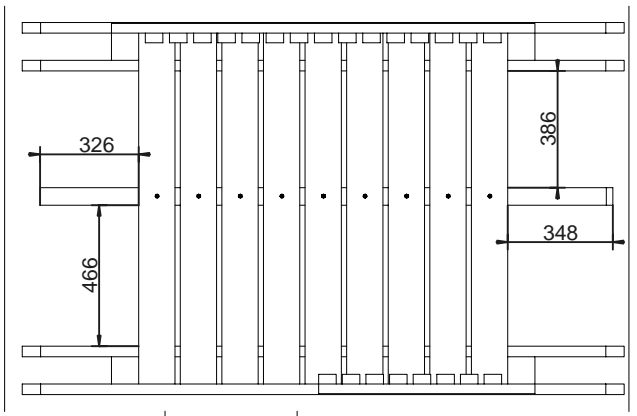
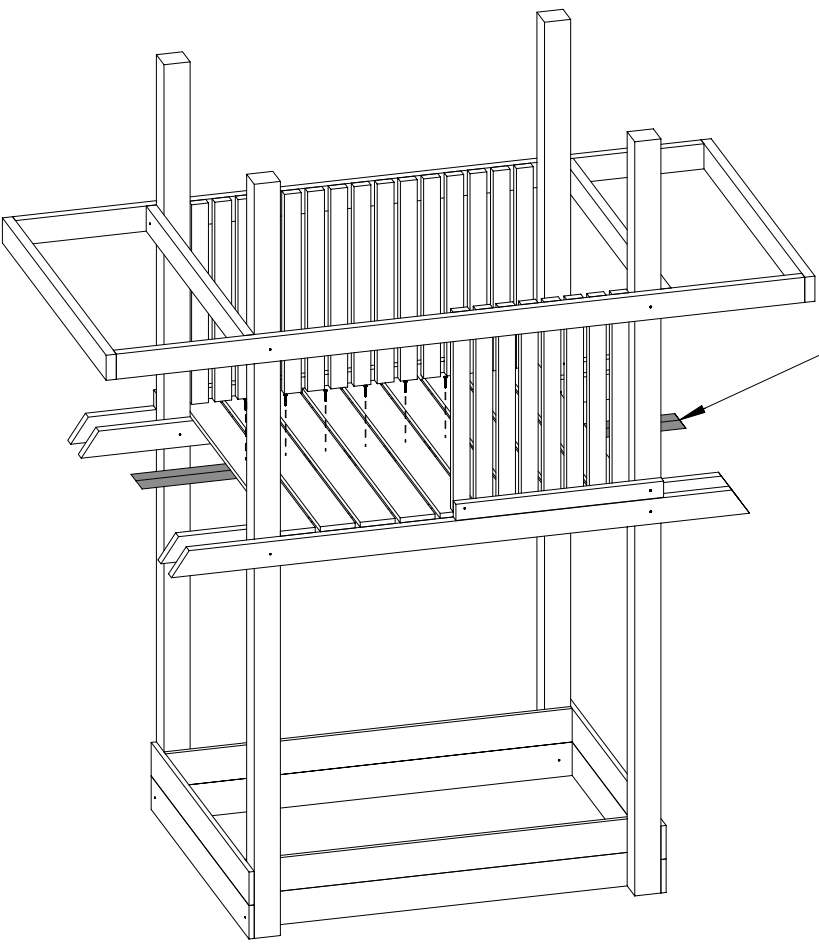

Zgodne z normą PN-EN 71 stosuj zalecenia producenta odnośnie odległości oraz metody mocowania poszczególnych elementów
 In compliance with the standard PN-EN 71, apply guidelines of the producer in relation to distances and methods of fastening individual elements

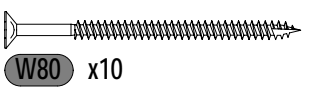
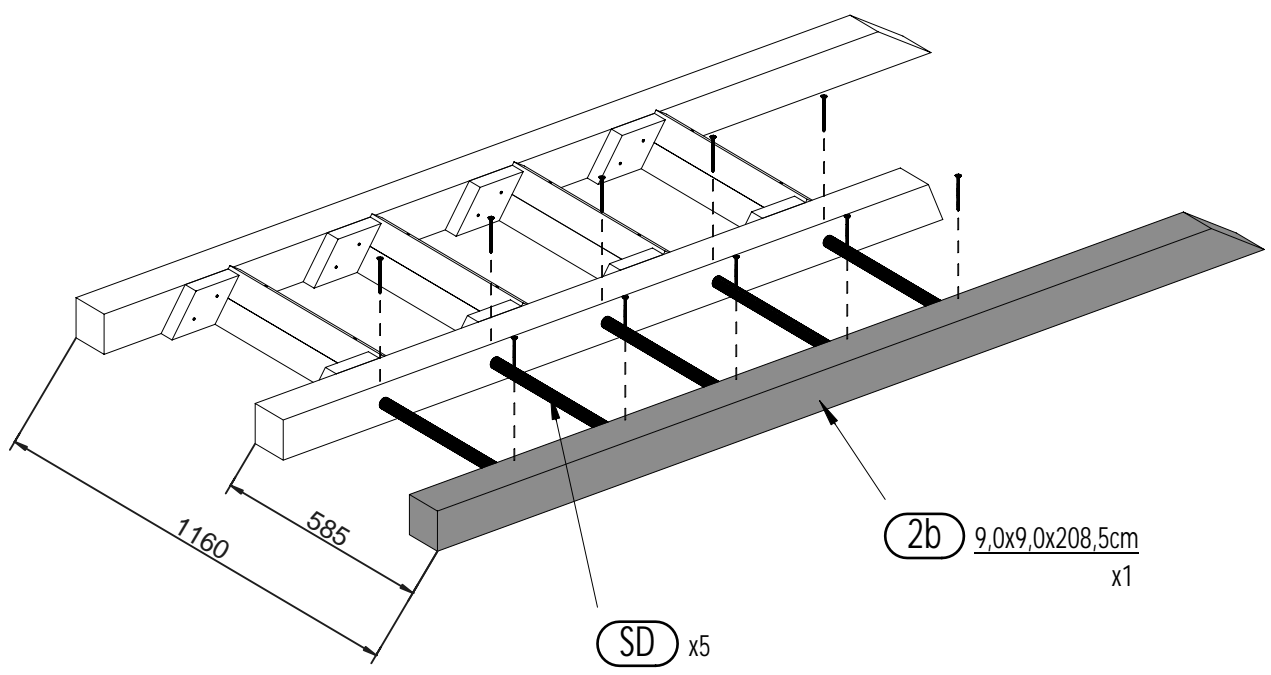
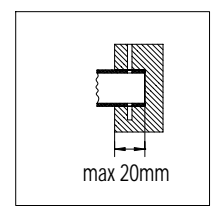
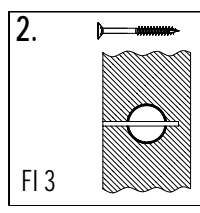
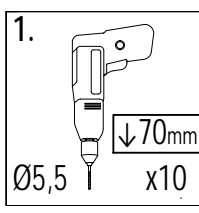
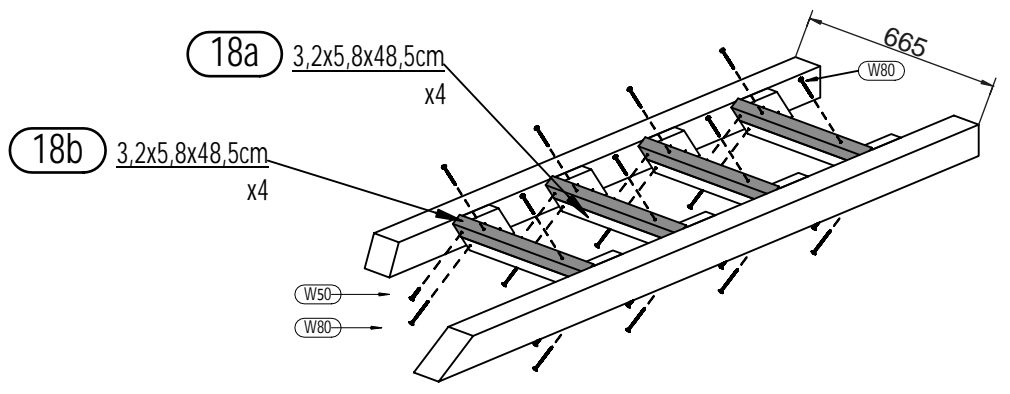
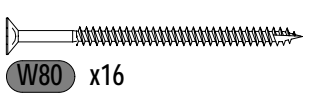
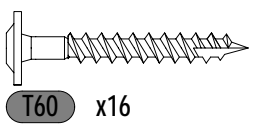
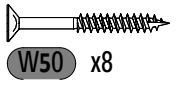
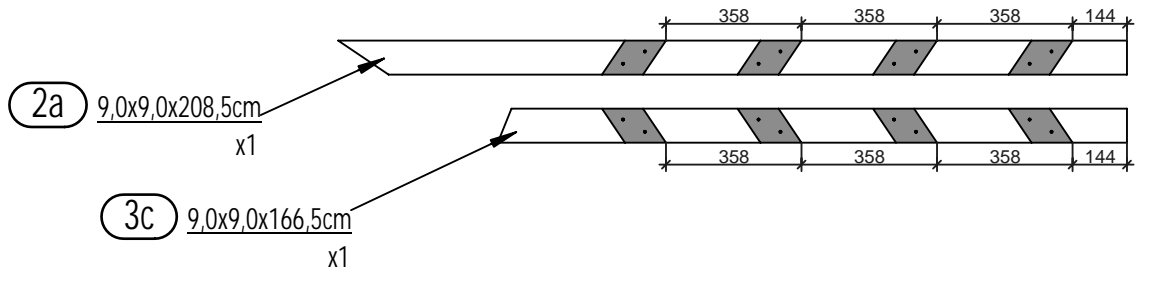
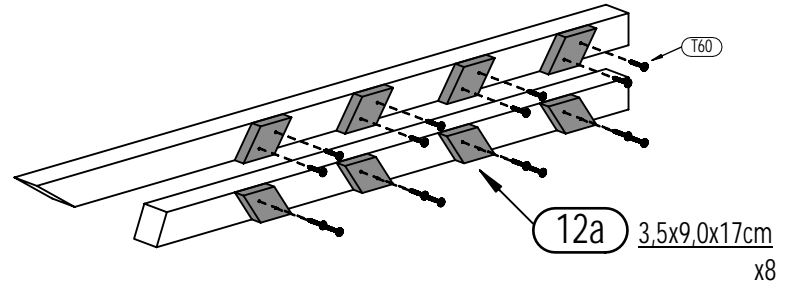
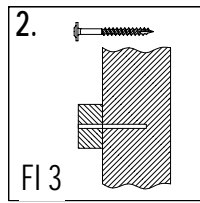
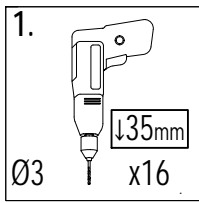

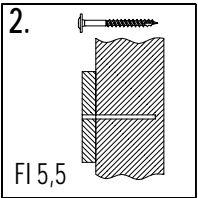
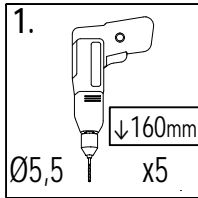
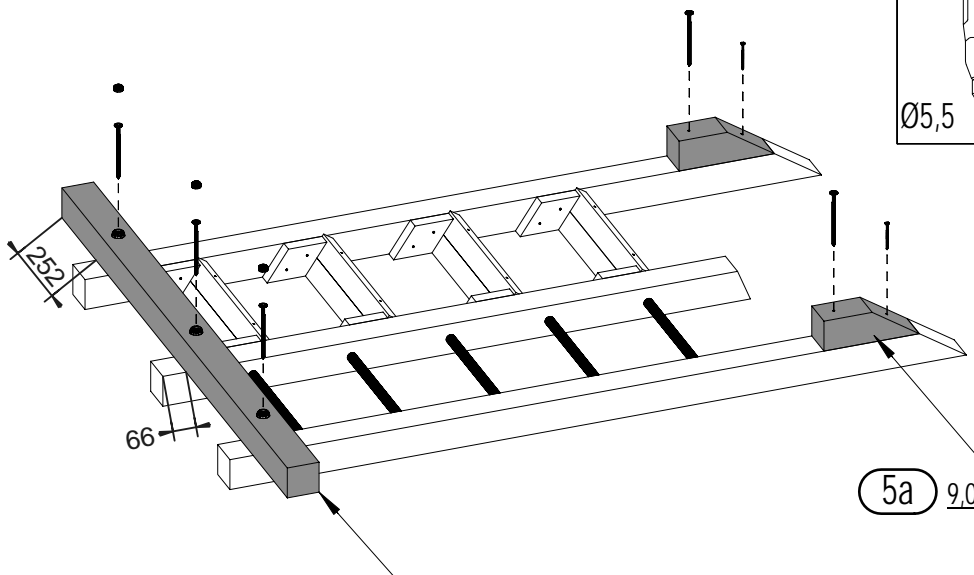

5a 9,0x9,0x270cm
x2

3b 9,0x9,0x166,5cm
x1

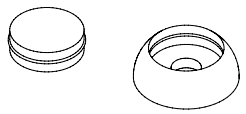
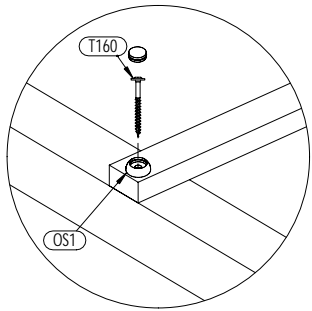

OS1 x3

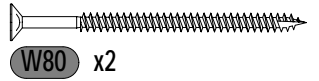

W80 x2

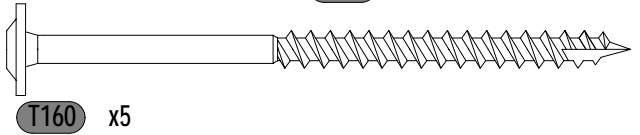

T160 x5

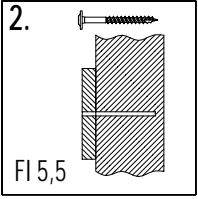
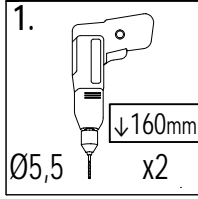
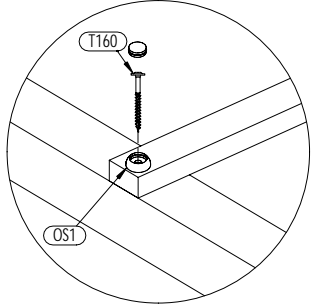

4a 9,0x9,0x350cm
x2

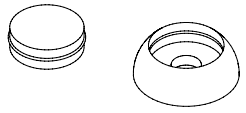
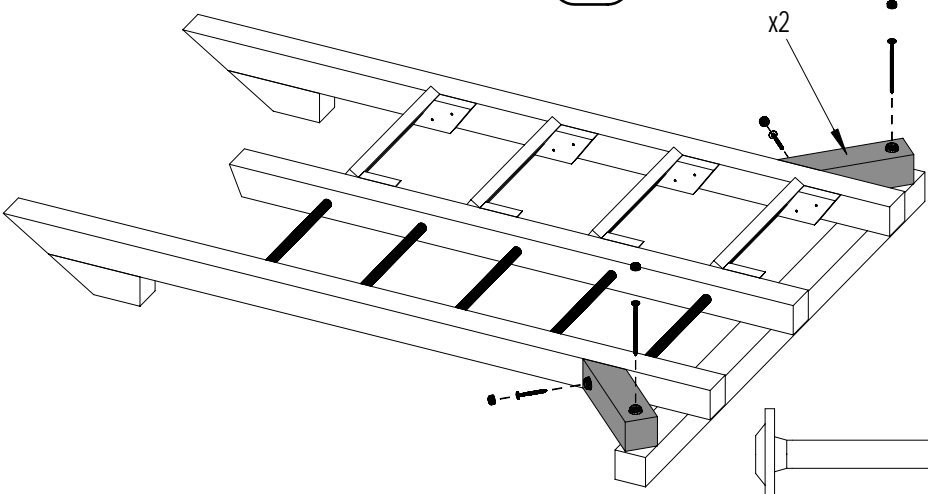

OS1 x4

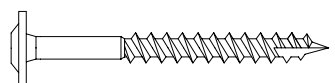

T80 x2

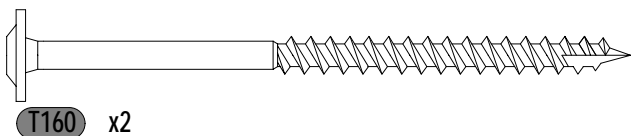

T160 x2

16a 3,2x5,8x125cm

x3

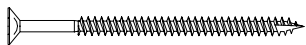
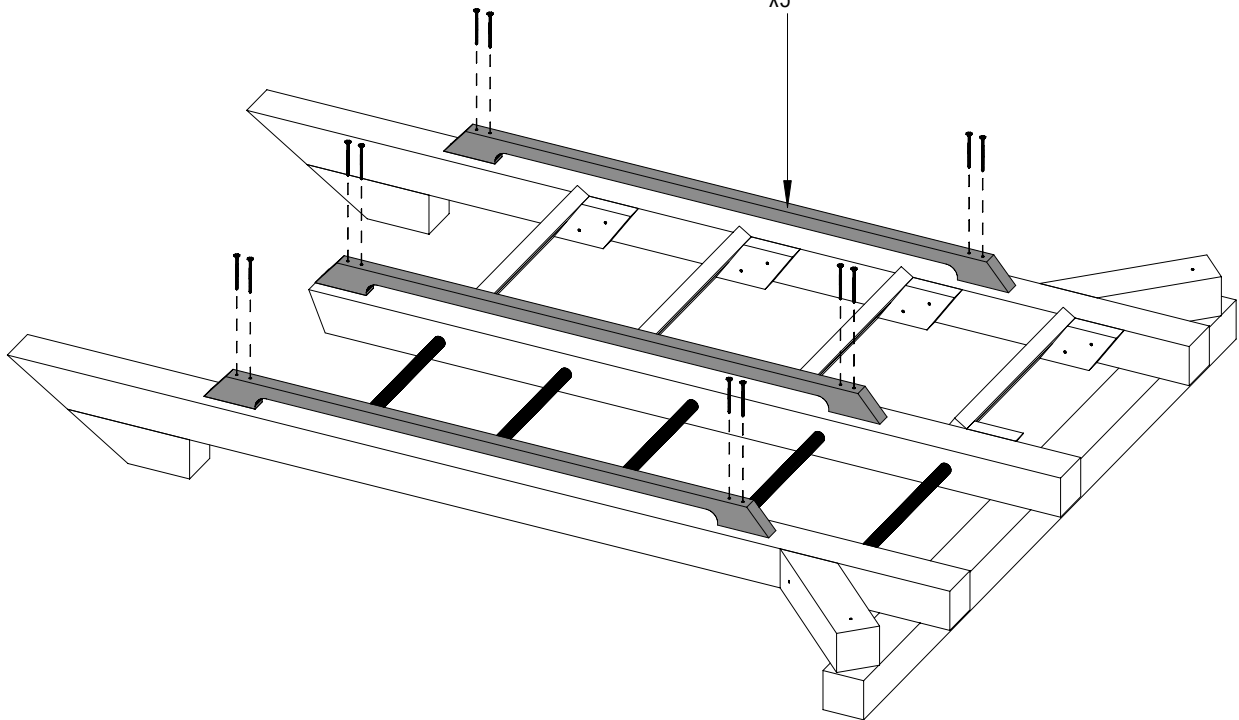

W80 x12

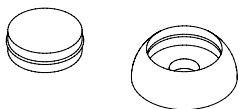
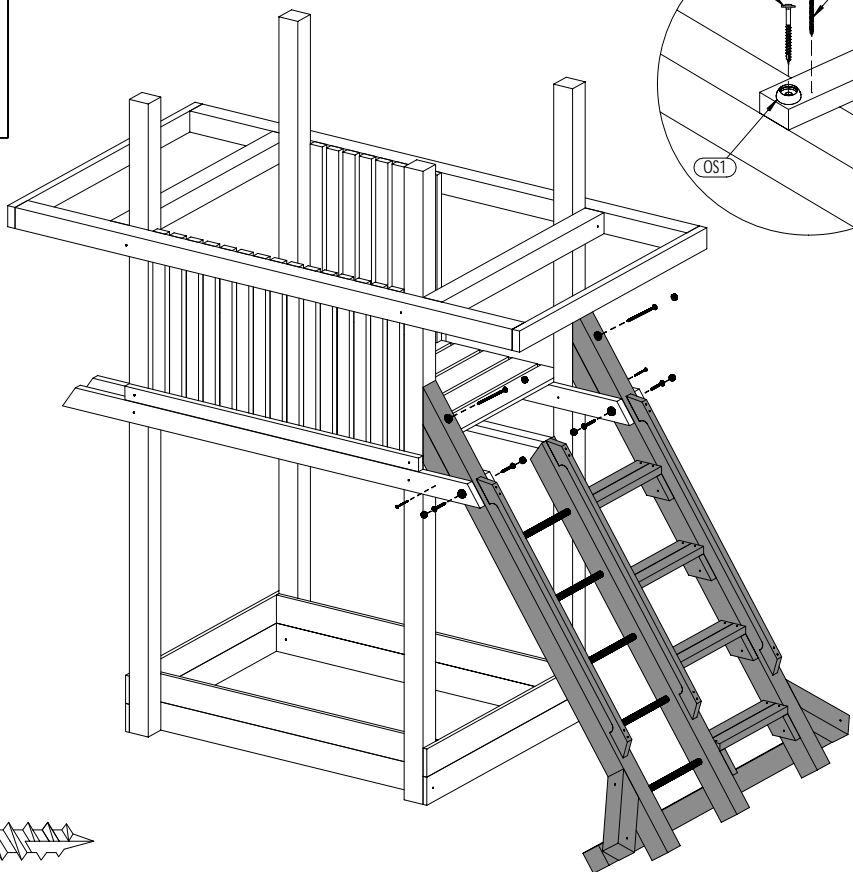
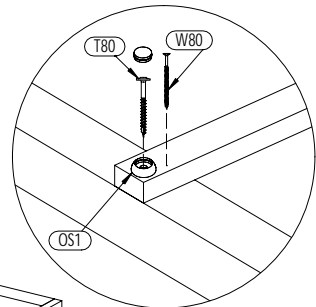
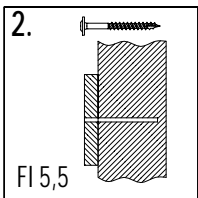
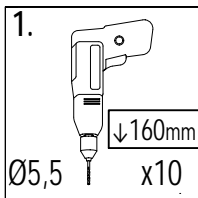

OS1 x6

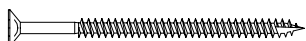

W80 x2



T80 x4

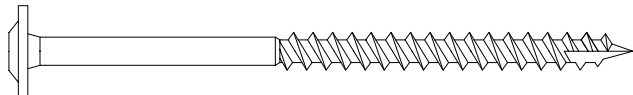

T160 x2

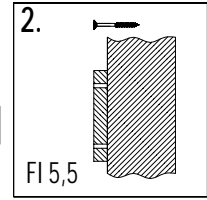
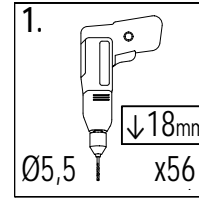
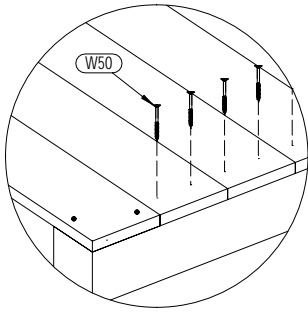

19

21b 1,8x12,0x116cm
x1

21 1,8x12,0x116cm
x13

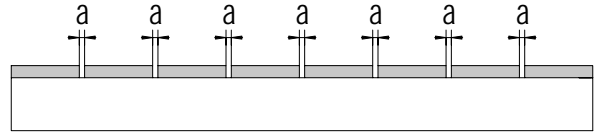

!!!min 2mm < a < !!!max 6mm

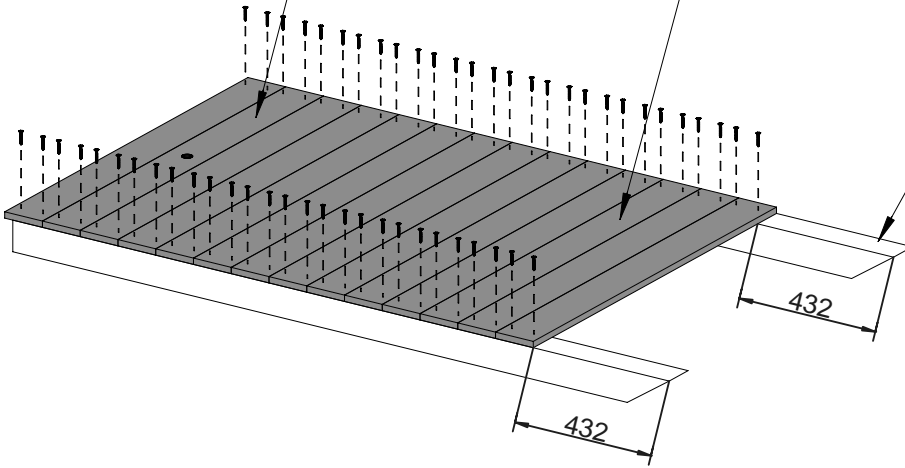

2a 9,0x9,0x208,5cm
x2

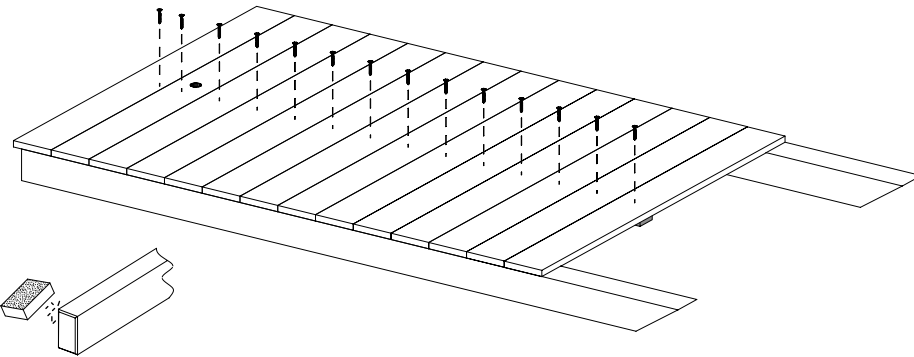
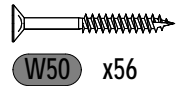
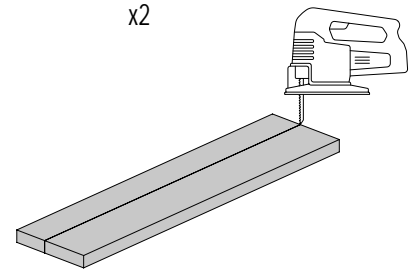

14 3,2x5,8x160cm
x1

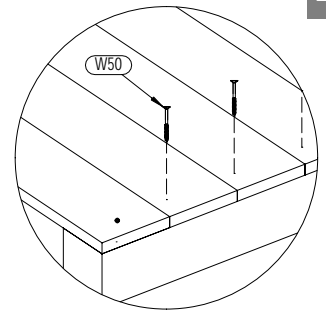

20

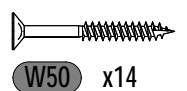
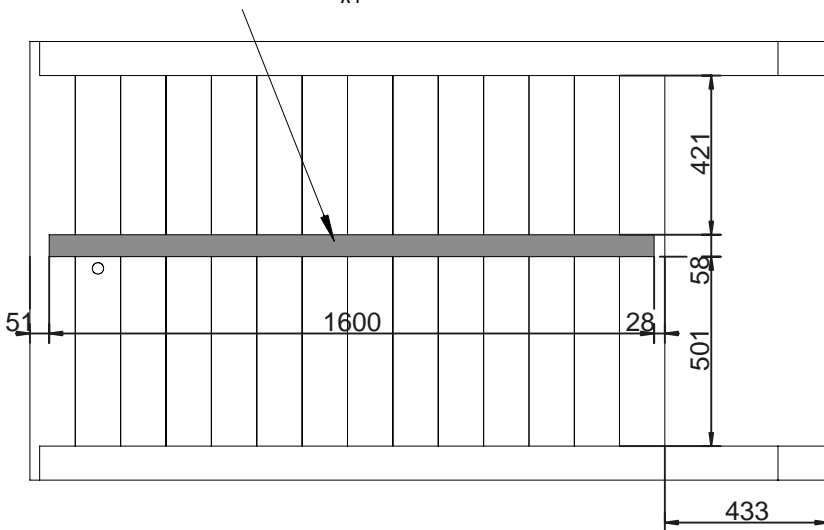

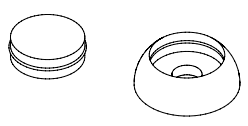
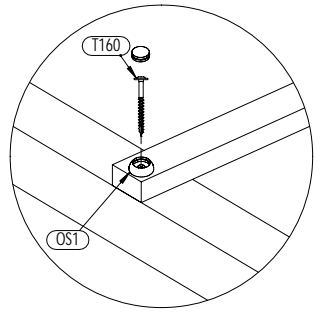
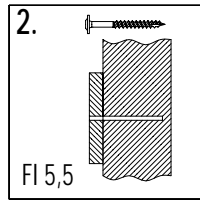
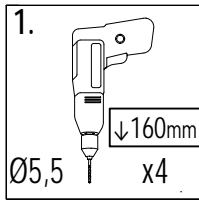

OS1 x2



W80 x2

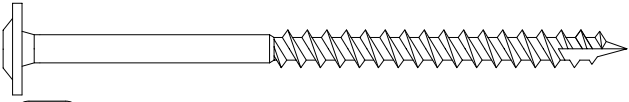

T160 x4

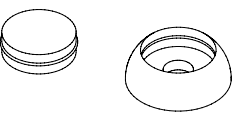
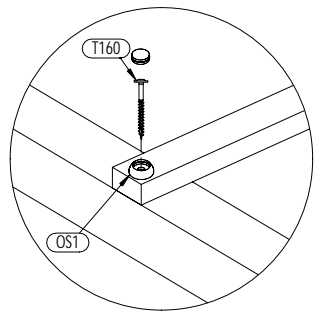
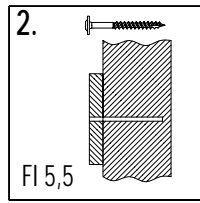
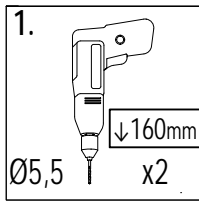
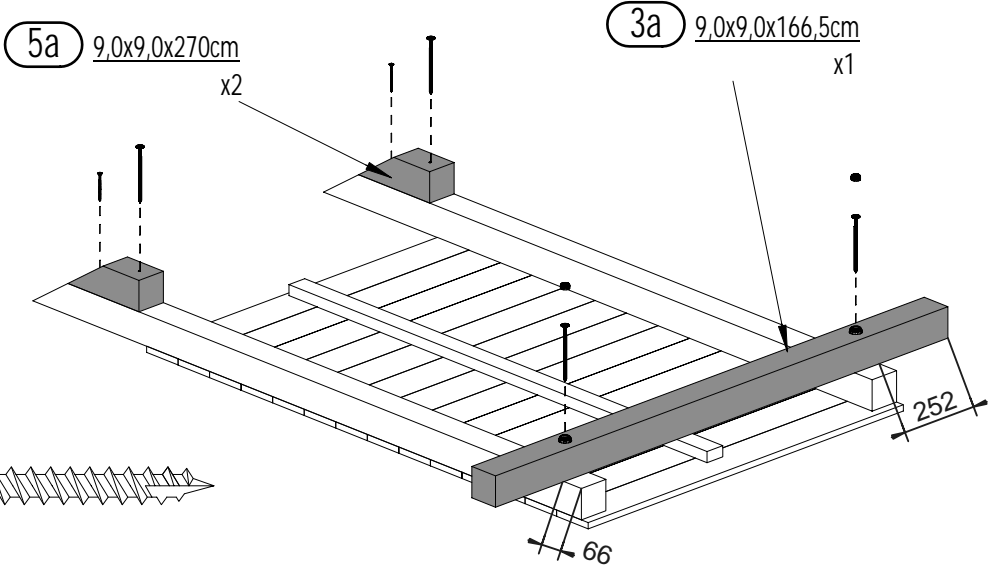

OS1 x4

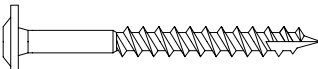

T80 x2



T160 x2

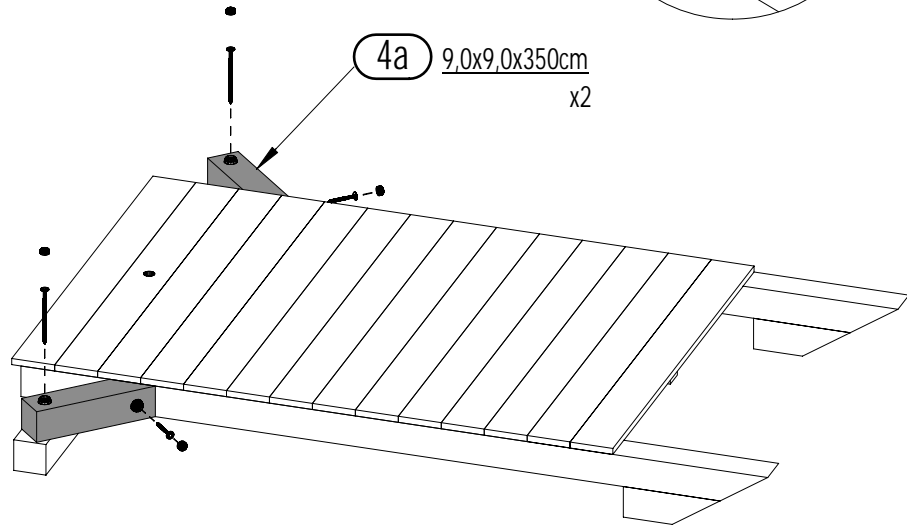

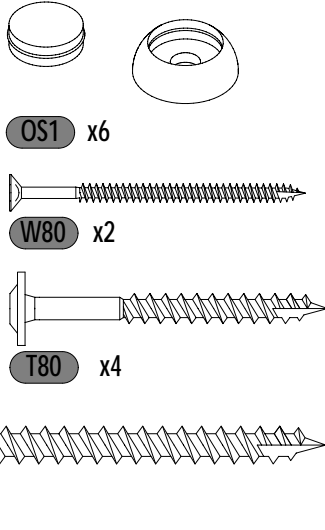
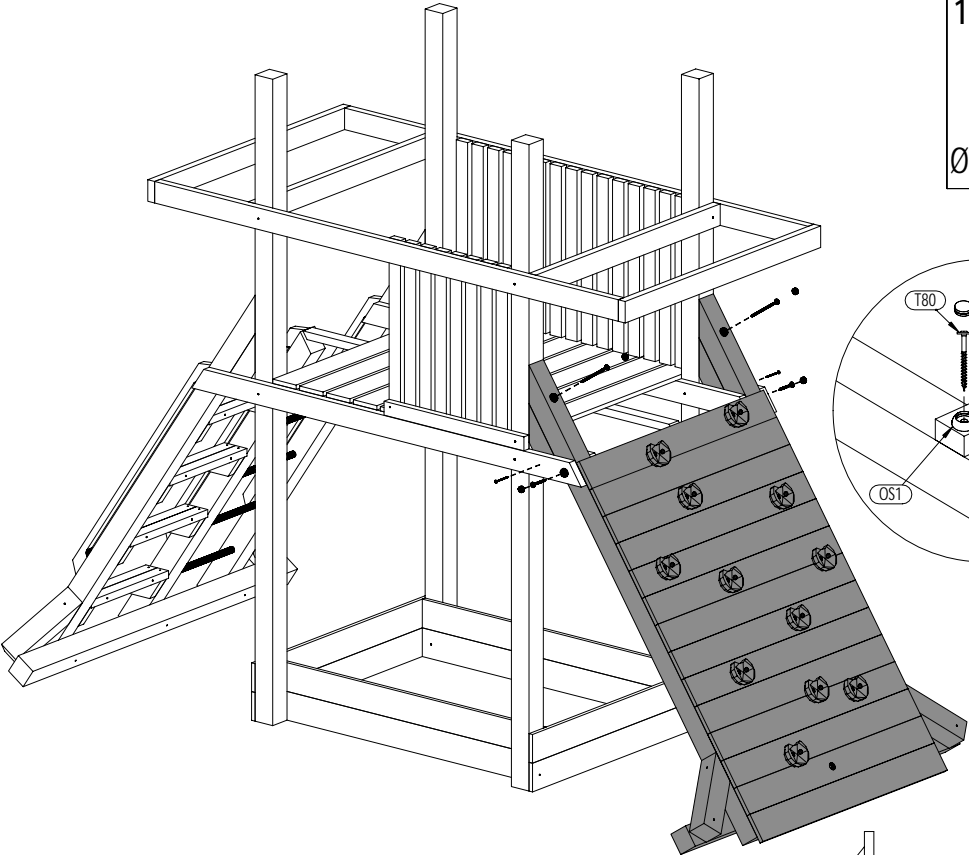
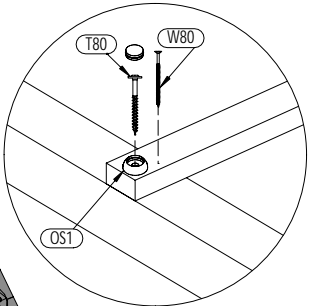
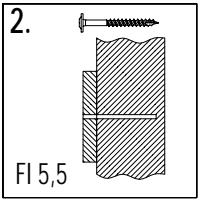
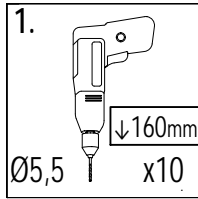
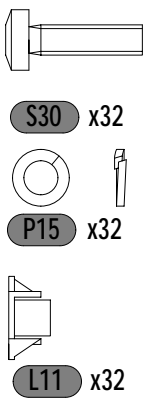
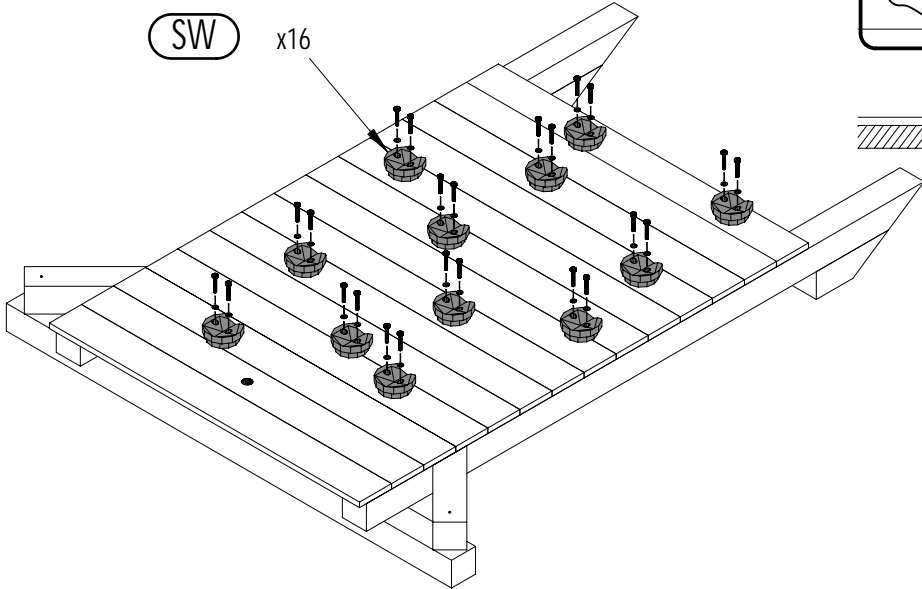
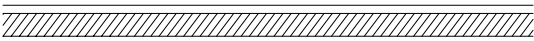
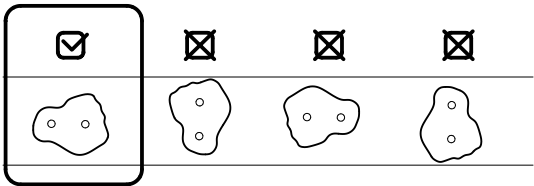
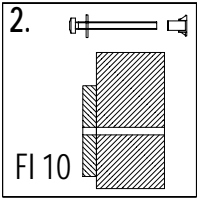
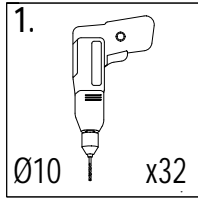
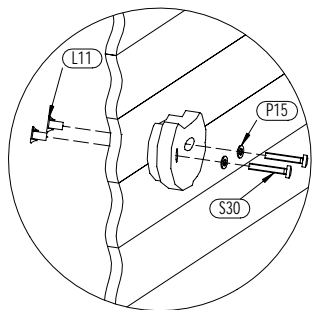

25

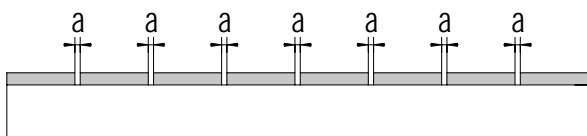
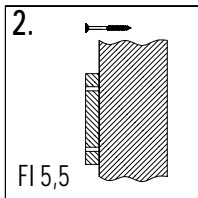
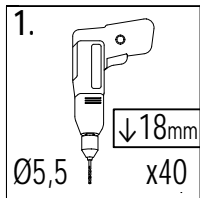

!!!min 2mm < a < !!!max 6mm

22 1,8x12,0x98cm
x6

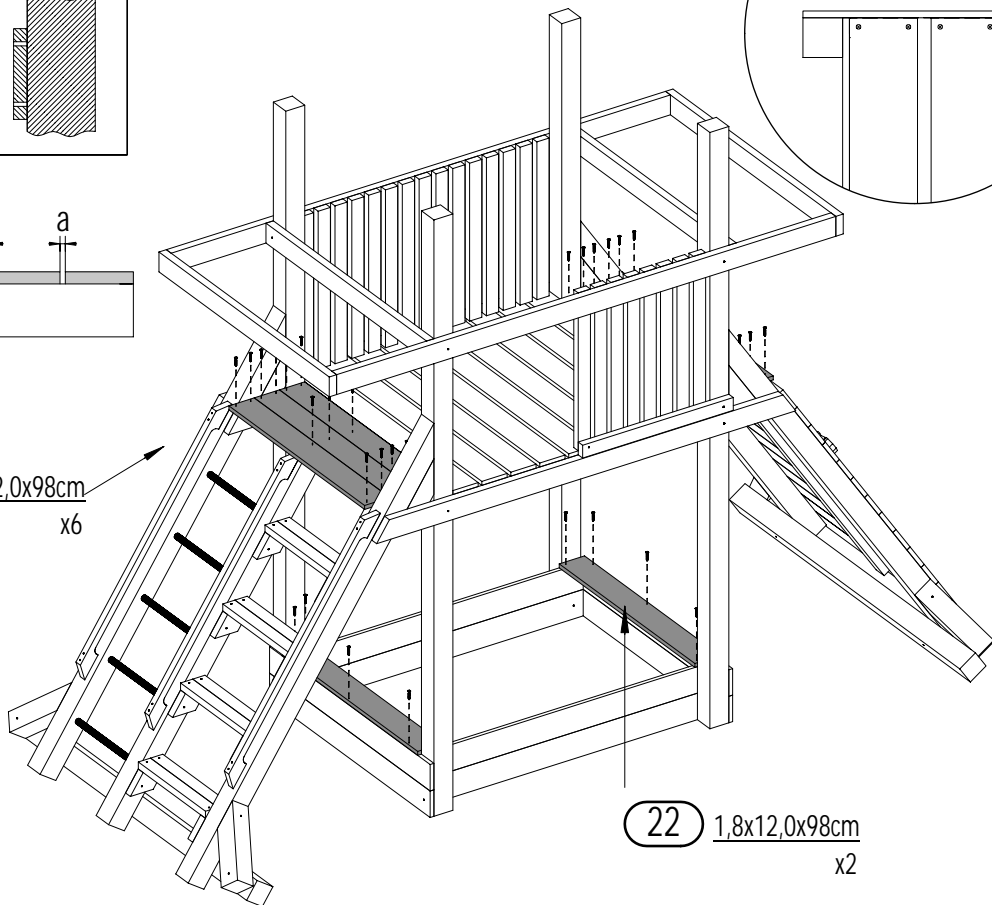
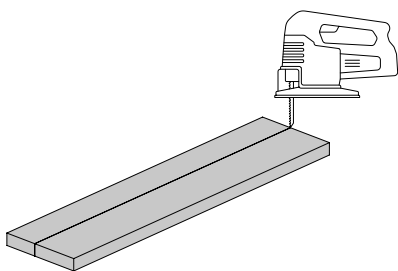

22 1,8x12,0x98cm
x2

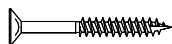

W50 x40

26

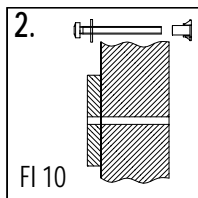
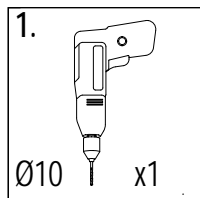

BL x1

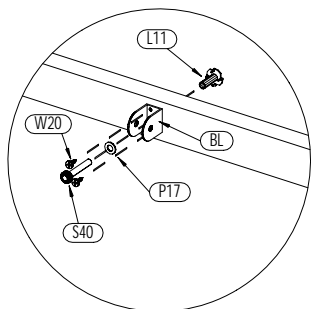

W20 x2



P17 x1



L11 x1

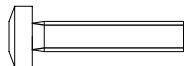

S40 x1

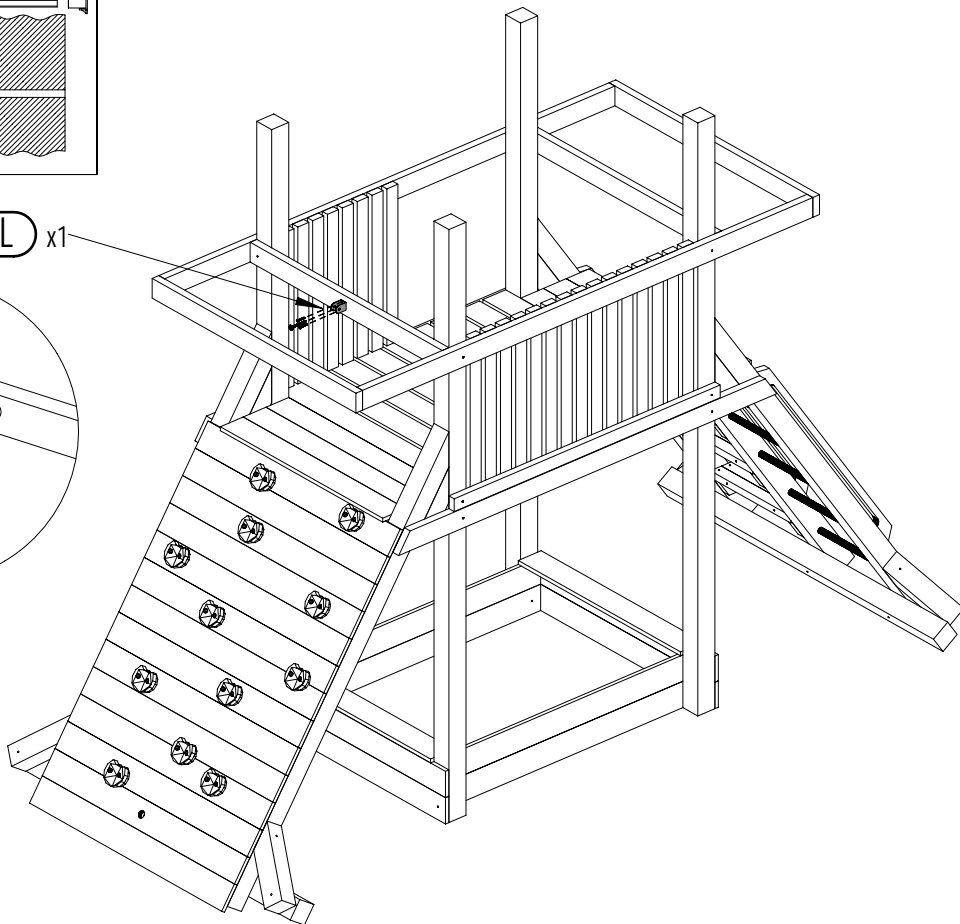

20

GIANT

Zgodnie z normą PN-EN 71 stosuj zalecenia producenta odnośnie odległości oraz metody mocowania poszczególnych elementów
In compliance with the standard PN-EN 71, apply guidelines of the producer in relation to distances and methods of fastening individual elements

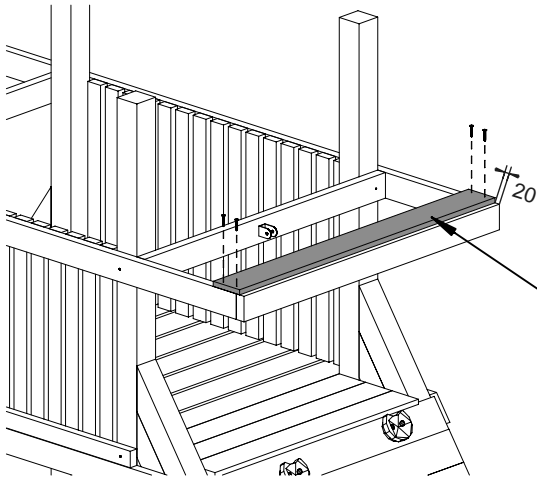

20 1,8x12,0x123cm
x2

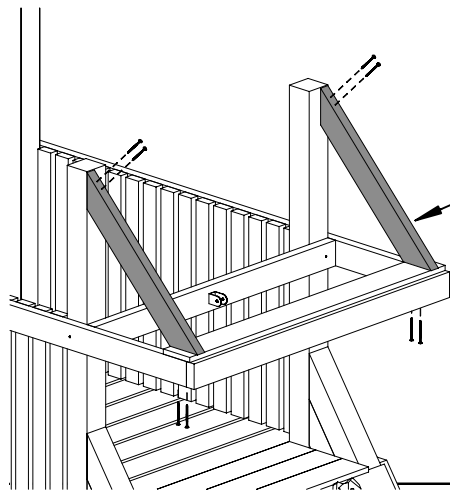
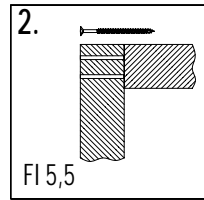
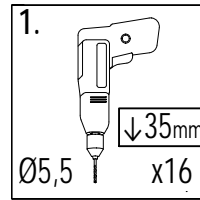

11a 3,5x9,0x72cm
x4

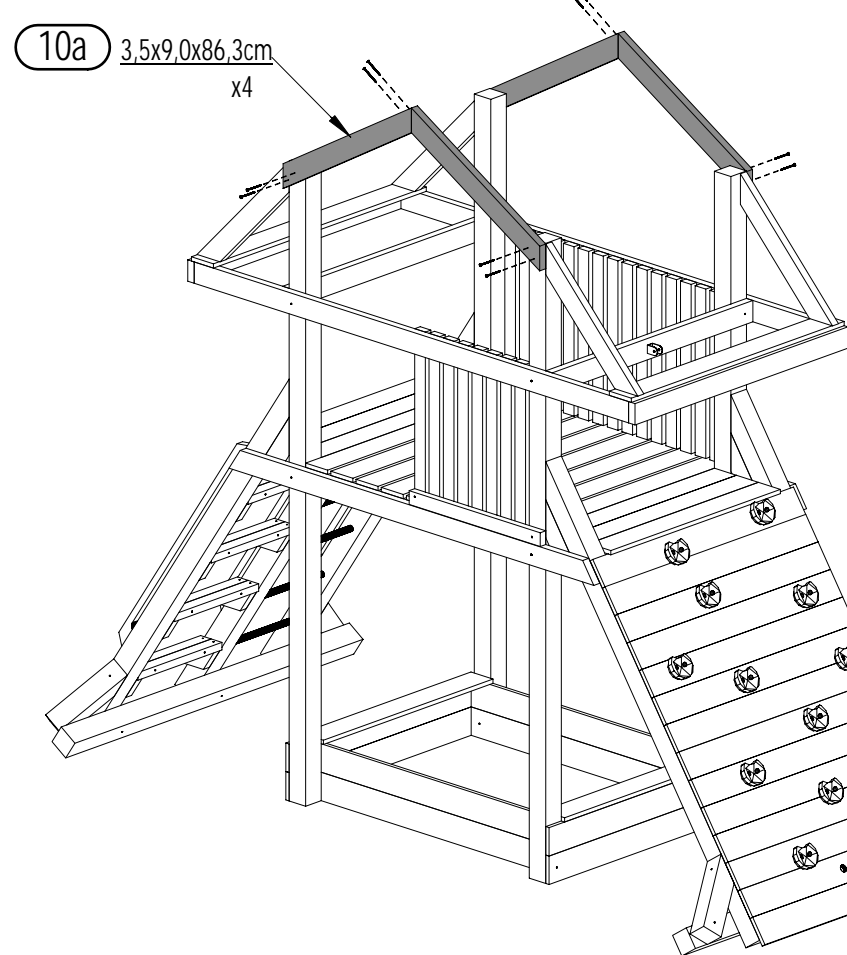
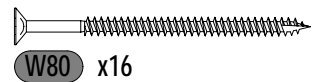
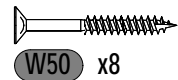

10a 3,5x9,0x86,3cm
x4

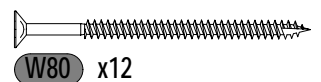
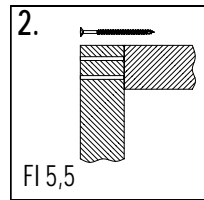
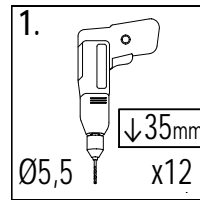

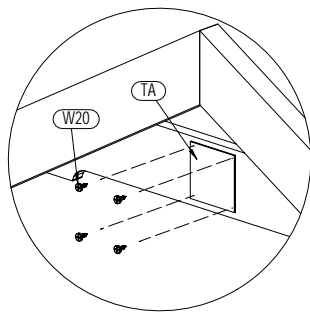

TA x2

23a 1,8x12,0x98cm x2

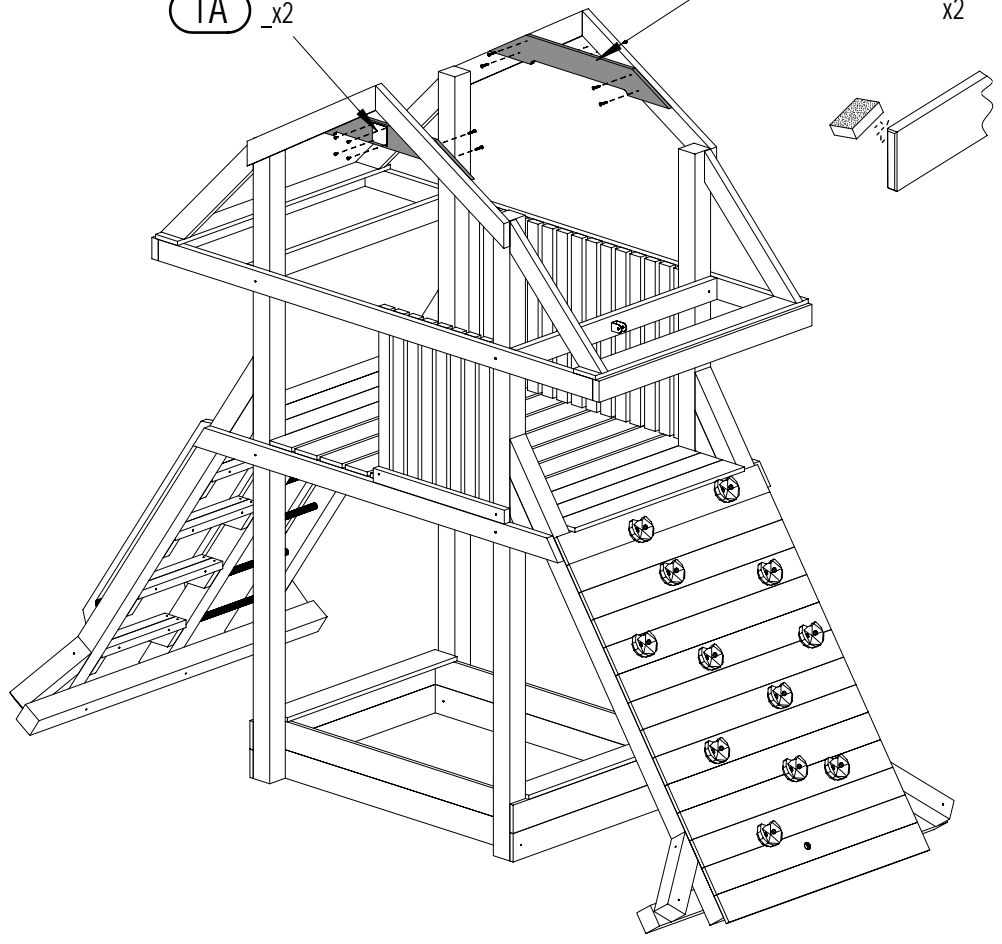

 W20 x8

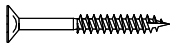
 W50 x8

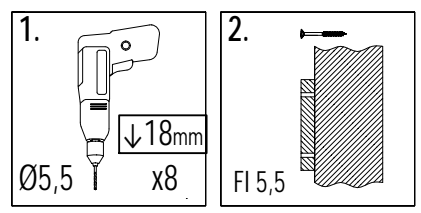

20 1,8x12,0x123cm x2

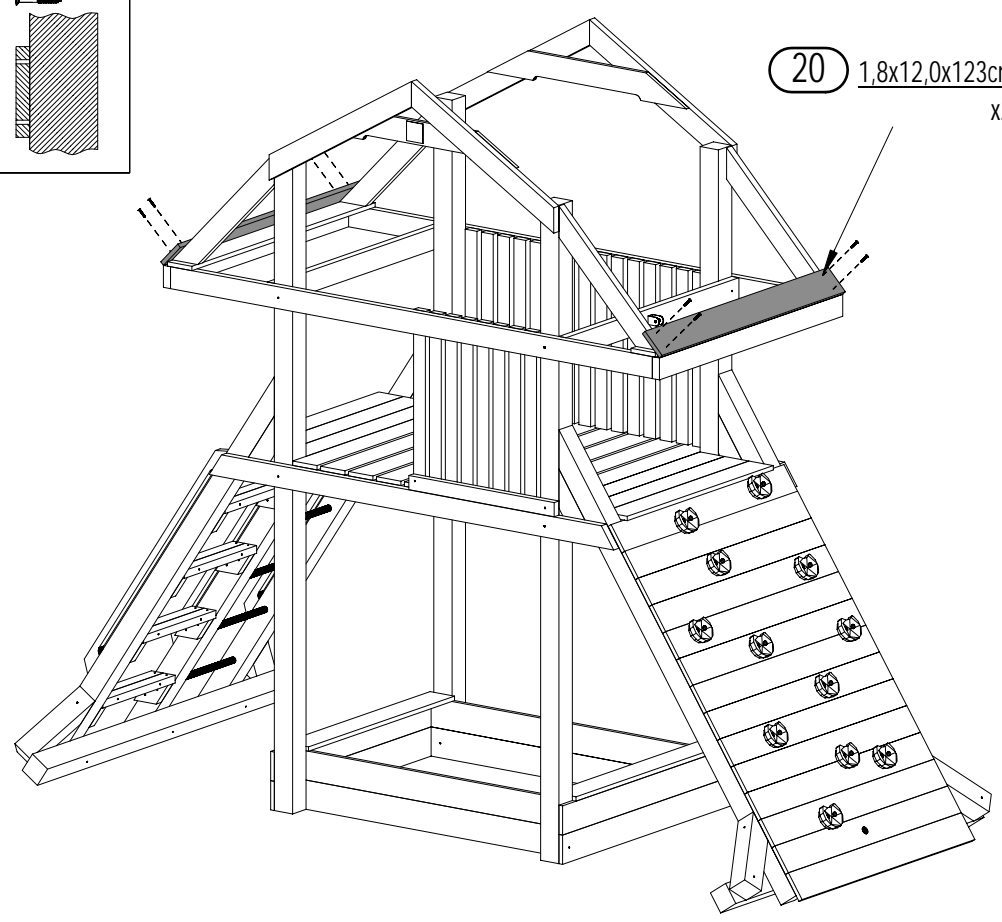

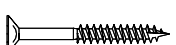
 W50 x8

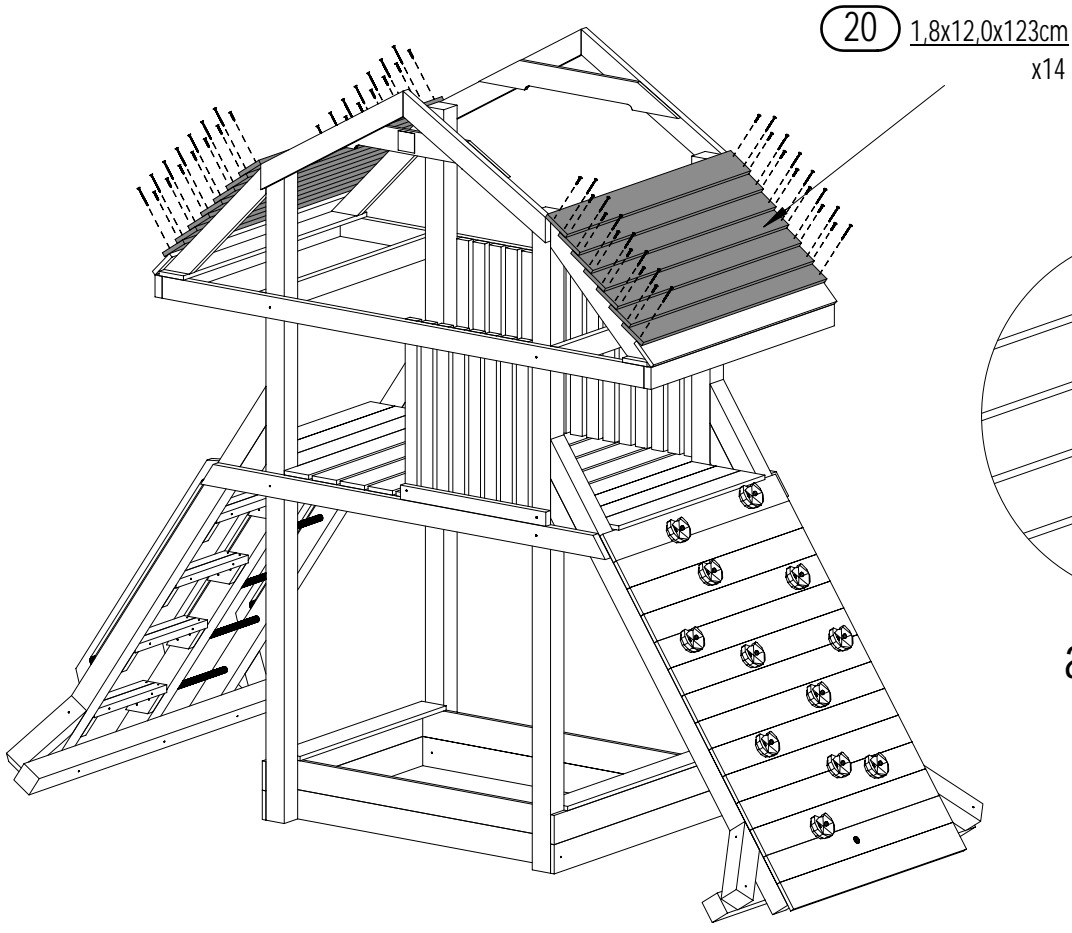

a ≈ 87mm

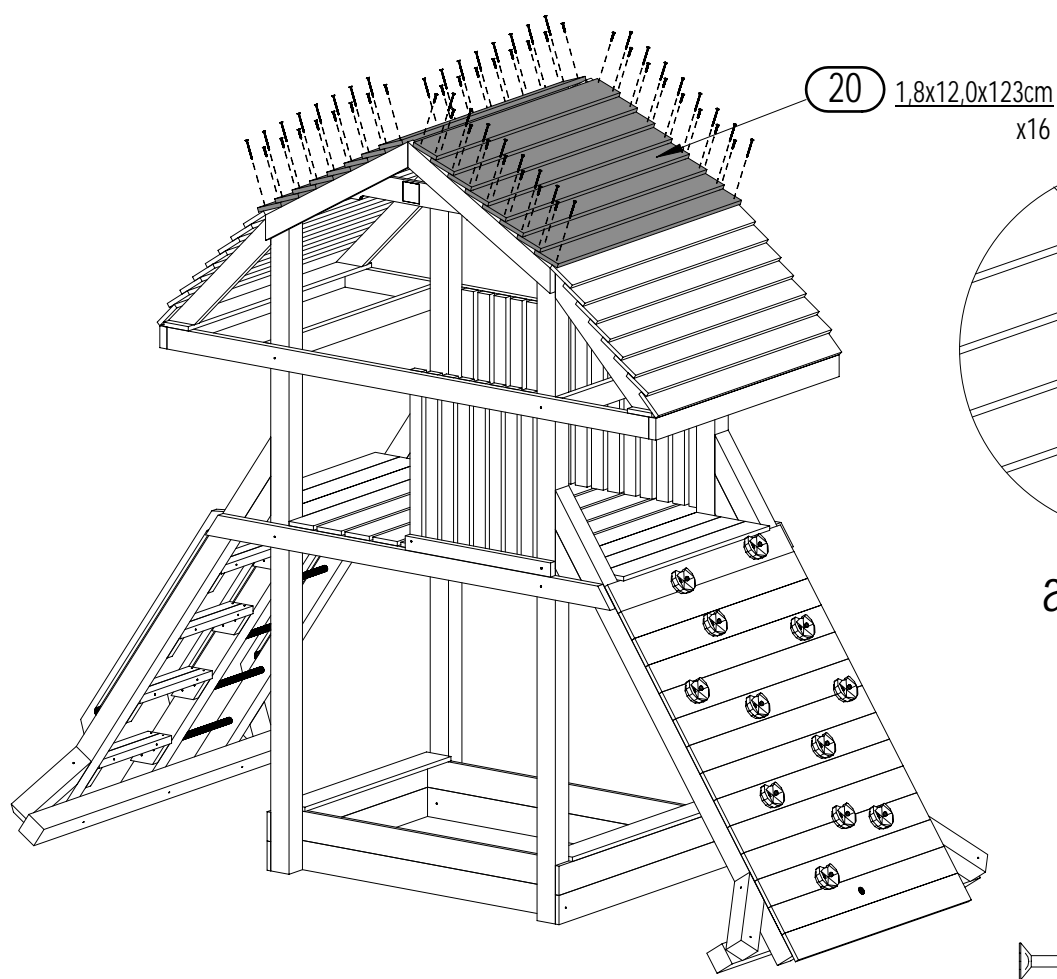
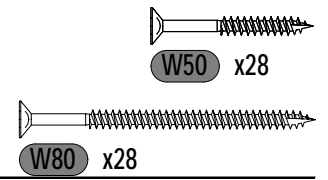

a ≈ 96mm

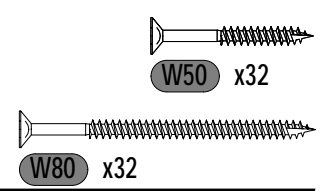

Zgodne z normą PN-EN 71 stosuj zalecenia producenta odnośnie odległości oraz metody mocowania poszczególnych elementów
 In compliance with the standard PN-EN 71, apply guidelines of the producer in relation to distances and methods of fastening individual elements

20 1,8x12,0x123cm x1

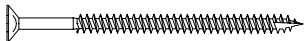
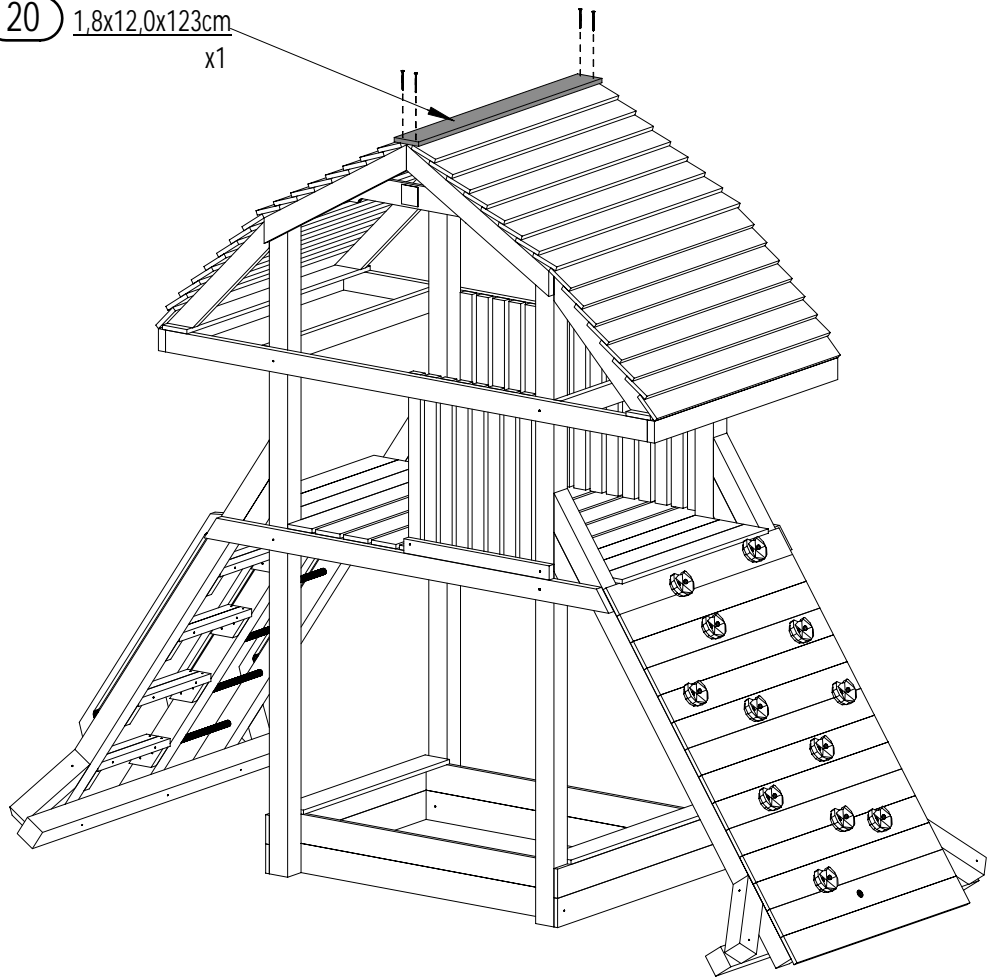

W80 x4

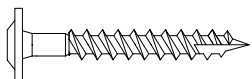
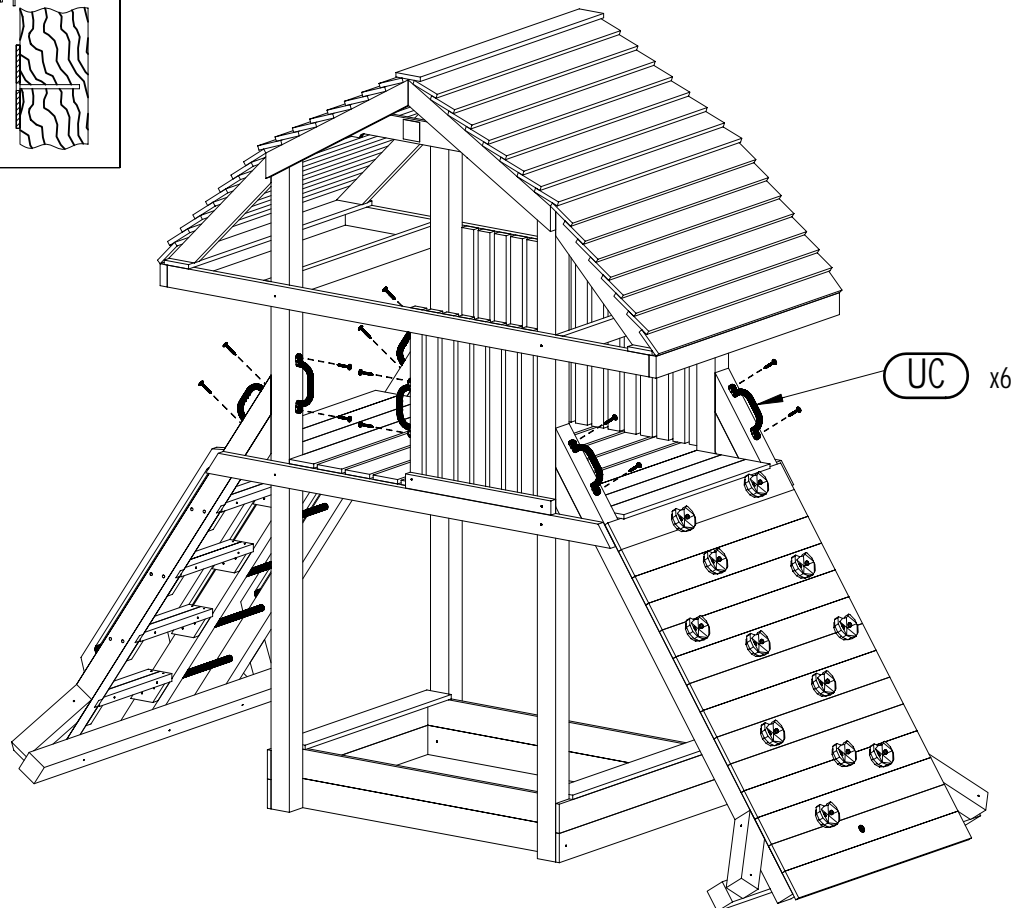
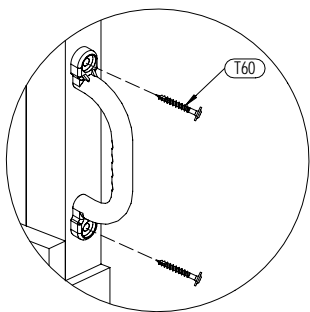
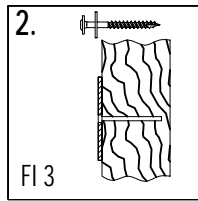
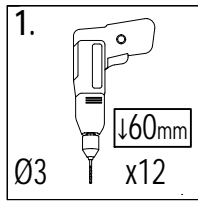

T60 x12

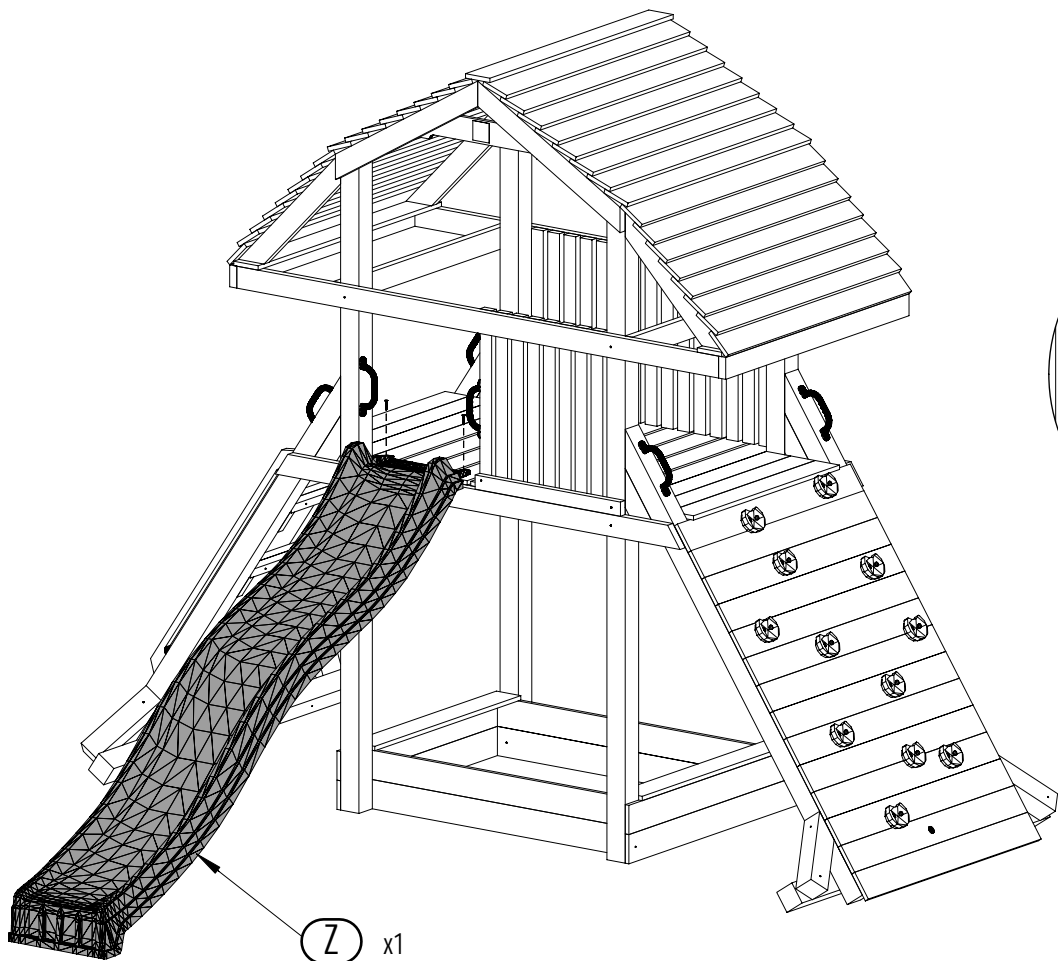

Z x1

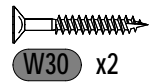

W30 x2

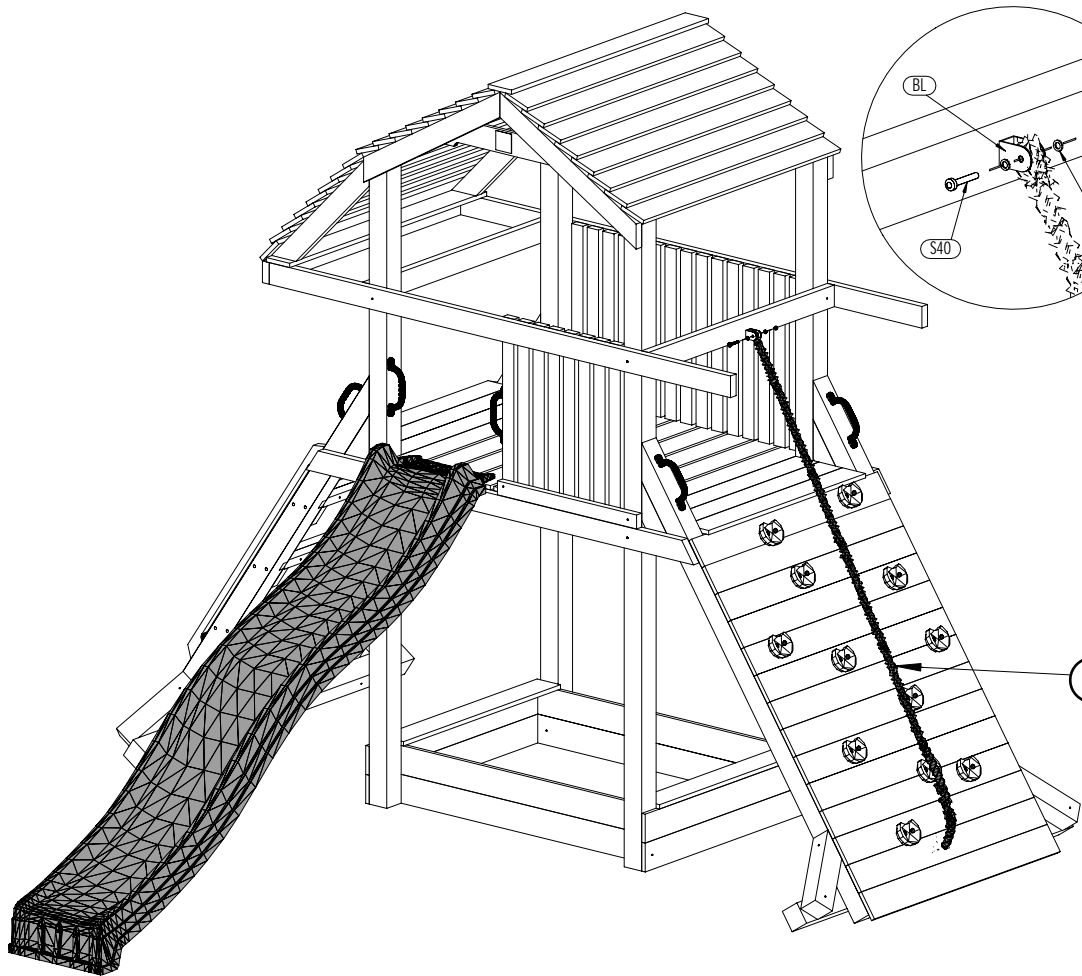

LI x1

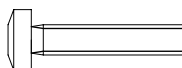

S40 x1



P17 x2



NS x1

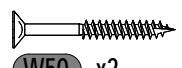

W50 x2

Zgodnie z normą PN-EN 71 stosuj zalecenia producenta odnośnie odległości oraz metody mocowania poszczególnych elementów
 In compliance with the standard PN-EN 71, apply guidelines of the producer in relation to distances and methods of fastening individual elements

37

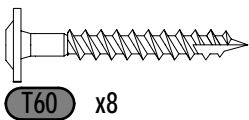
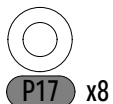
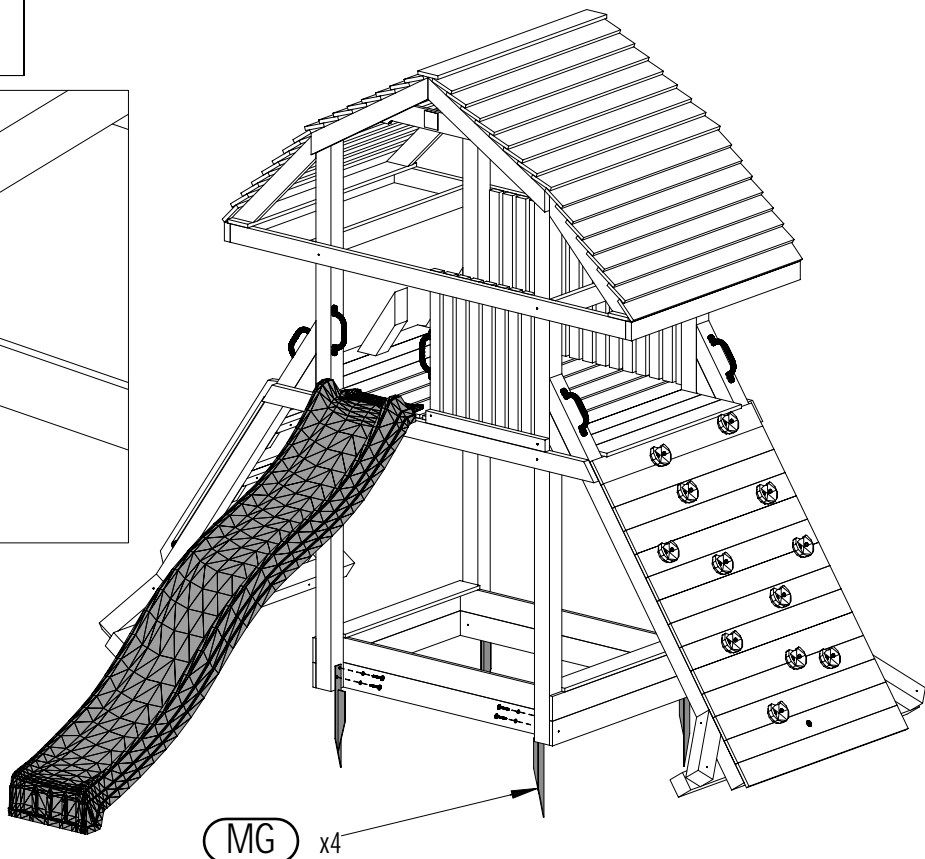
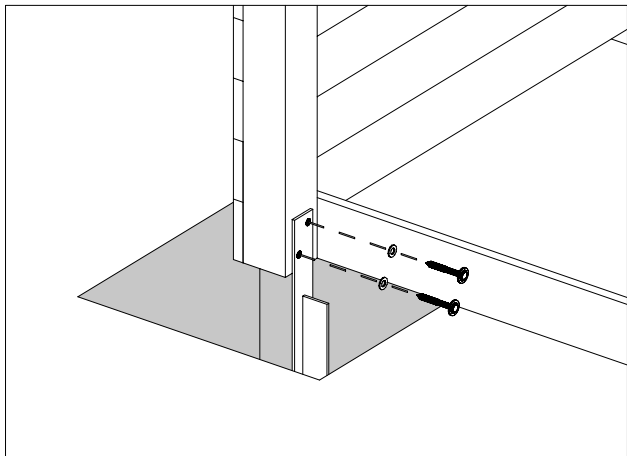
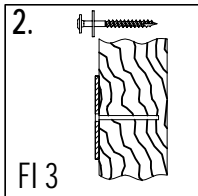
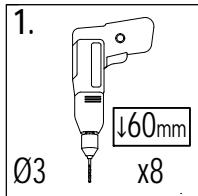

MG x4

38

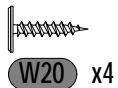
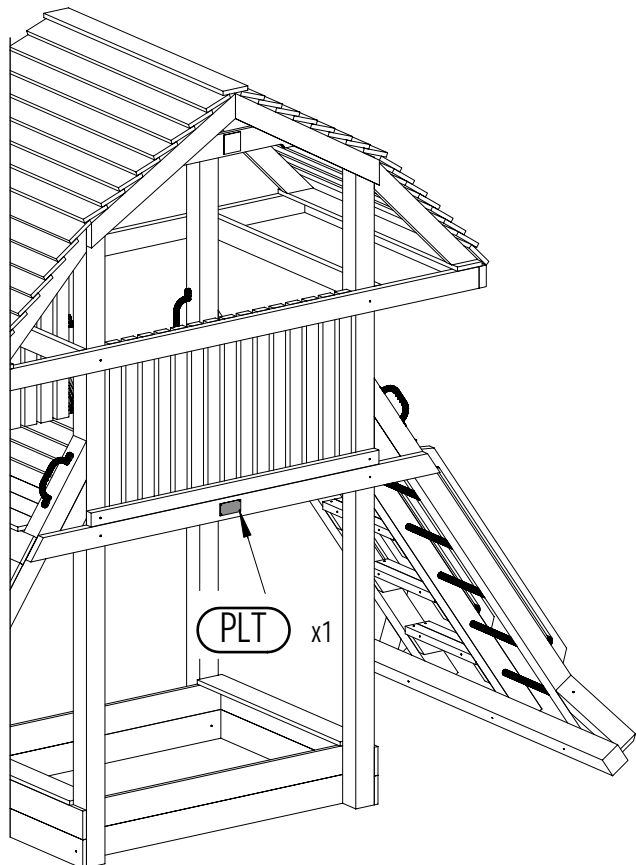
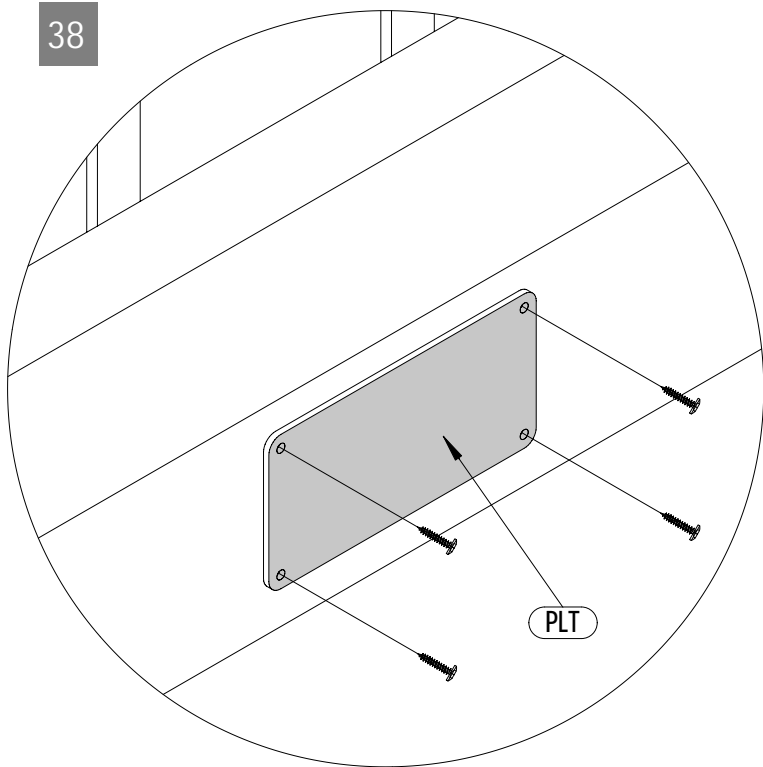

PLT x1

26

GIANT

Zgodnie z normą PN-EN 71 stosuj zalecenia producenta odnośnie odległości oraz metody mocowania poszczególnych elementów
 In compliance with the standard PN-EN 71, apply guidelines of the producer in relation to distances and methods of fastening individual elements

PLAYGROUND SPIELPLATZ

PLAC ZABAW AIRE DE JEUX

(305 x 253 x h240cm)

003_00650_02062021

MOVE PLUS

INSTALLATION INSTRUCTIONS
MONTAGEANLEITUNG

INSTRUKCJA MONTAŻU
GUIDE D'INSTALLATION

Warranty period - 2 years from purchase date

Garantiezeit - 2 Jahre ab Kaufdatum

Okres gwarancji - 2 lata od momentu zakupu towaru

Période de garantie - 2 ans à compter de l'achat

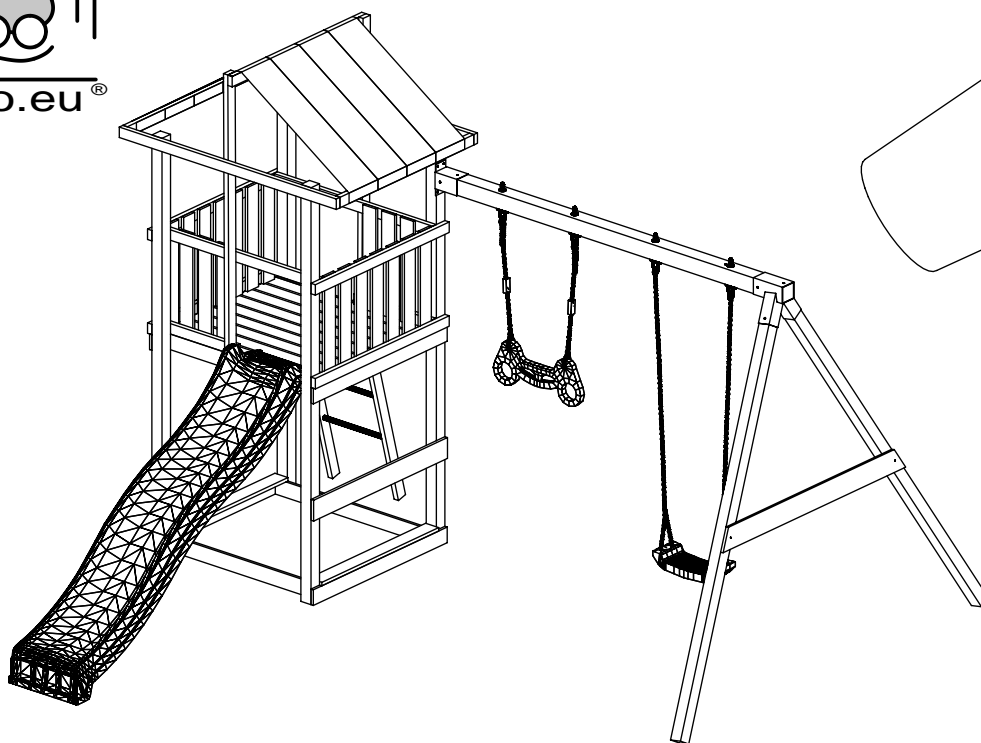

CE
EN - 71

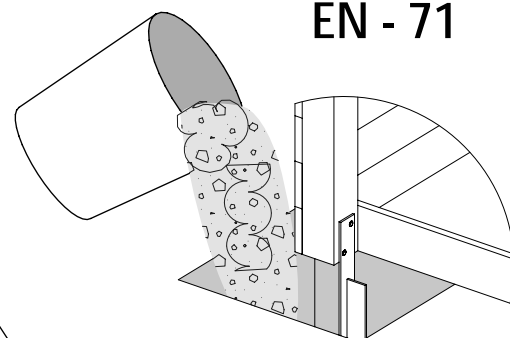

WARNINGS!

Only for home use.

Dedicated for external use only.

Not suitable for children under 3 years old.

Risk of falling down and/or hitting.

Maximum user weight is up to 50 kg.

Maximum number of users staying on the playground at the same time: 2.

OSTRZEŻENIA!

Tylko do użytku domowego.

Przeznaczony do użytku na zewnątrz.

Nie przeznaczony dla dzieci poniżej 3 roku życia.

Niebezpieczeństwo upadku i/lub uderzenia.

Maksymalna waga użytkownika to 50 kg.

Maksymalna liczba użytkowników przebywających na placu zabaw w tym samym czasie: 2.

ACHTUNG!

Nur für den privaten, häuslichen Bereich.

Ausschließlich für die Verwendung im Freien.

Nicht geeignet für Kinder unter 3 Jahren.

Stolper- und / oder Sturzgefahr

Höchstgewicht pro Einzelkind beträgt 50 kg

Der Aufenthalt auf diesem Spielturm ist max. : 2.
Kindern gleichzeitig erlaubt.

AVERTISSEMENT!

Aire exclusivement destinée à un usage privé.

Aire exclusivement destinée à un usage en extérieur.

Prévue pour les enfants de plus de 3 ans.

Danger de chute ou de choc.

Poids maximal d'un utilisateur : 50 kg.

Nombre maximal d'utilisateurs présents en même temps sur la même aire de jeux: 2.

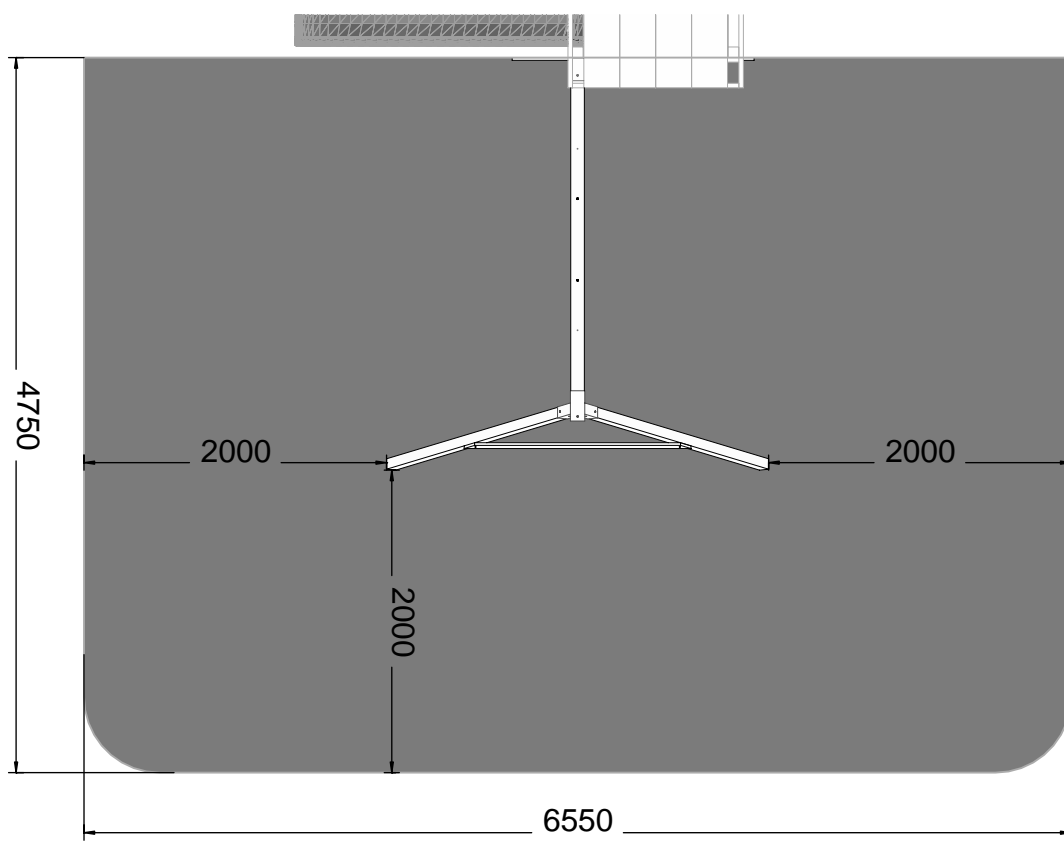

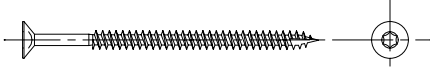

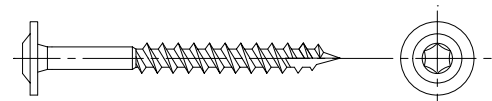
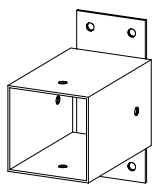
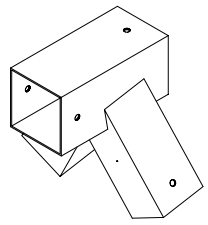
- W80 x8
 

- T80 x4
 

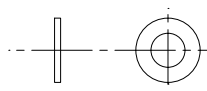

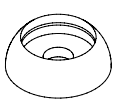
- T60 x17
 
MH x1 00937
TH x1 00936

- P17 x17
 

- OS1 x4
 

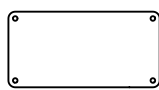
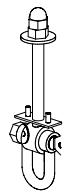
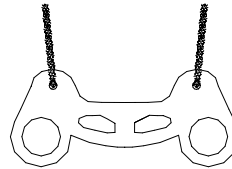
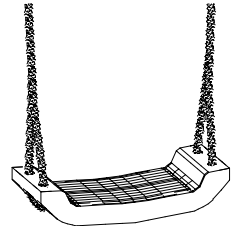
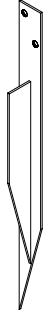
- W20 x4
 

- 
PLT x1 00197

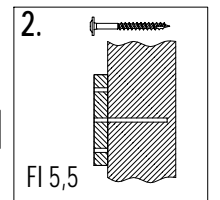
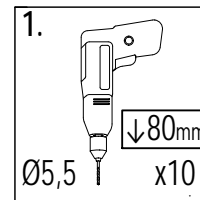
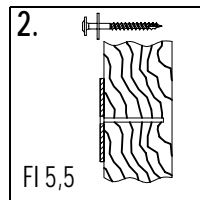
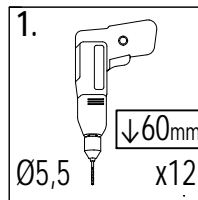
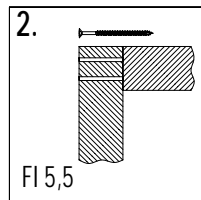
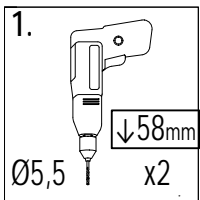
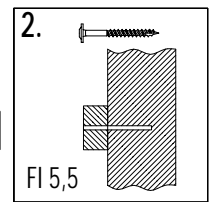
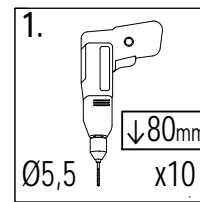
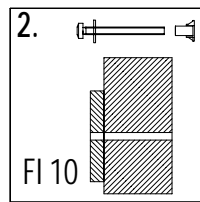
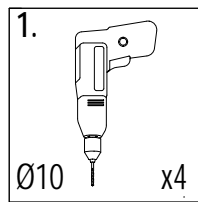
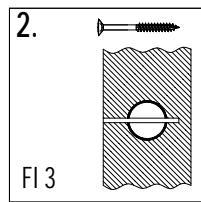
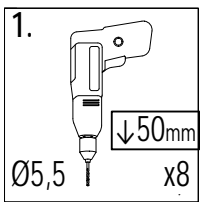
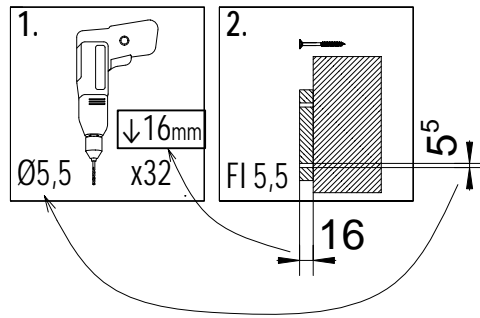
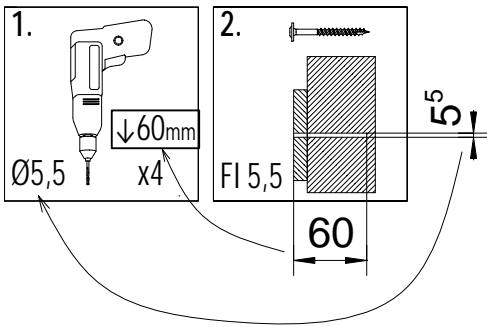
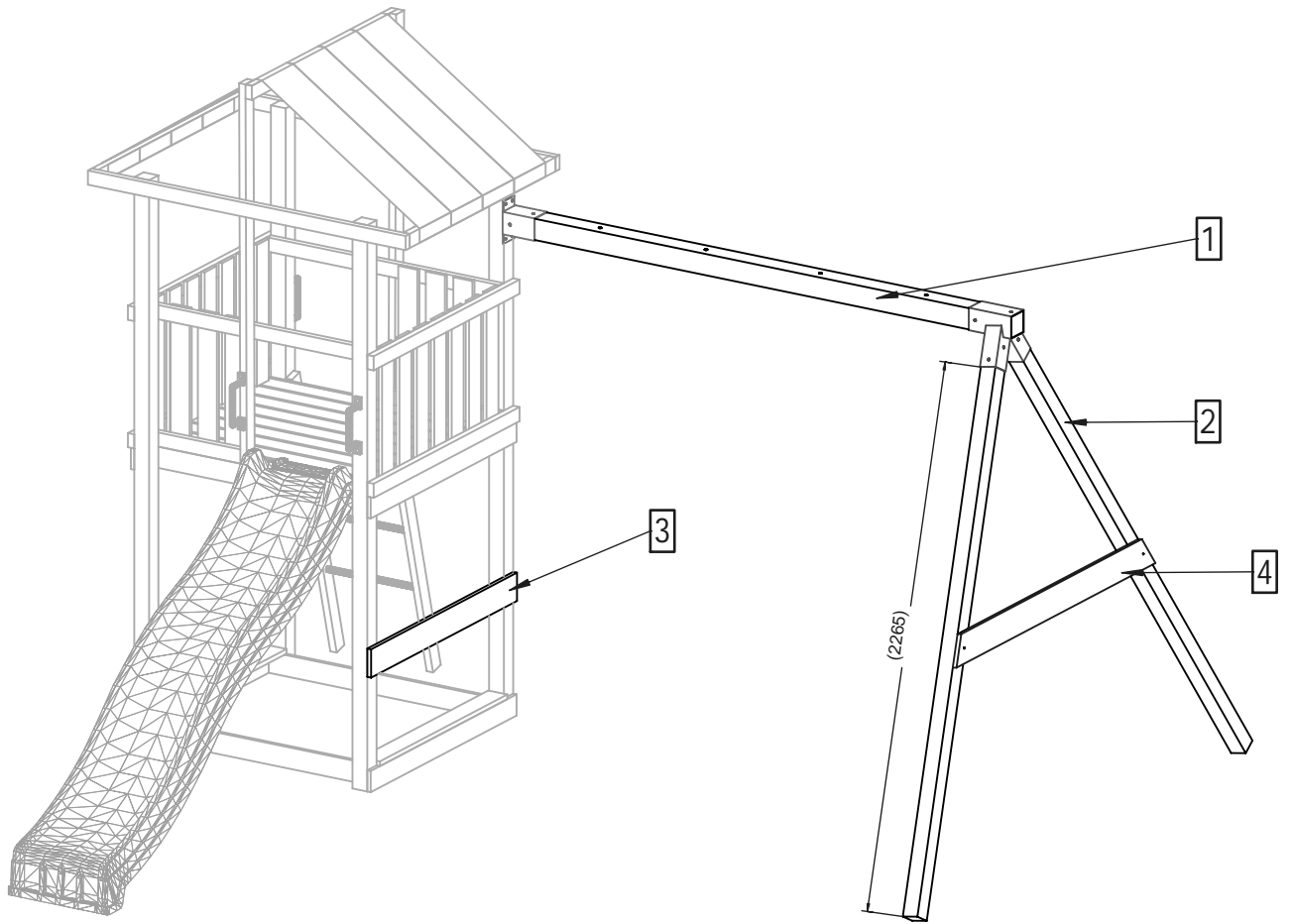
ZA x4 00002

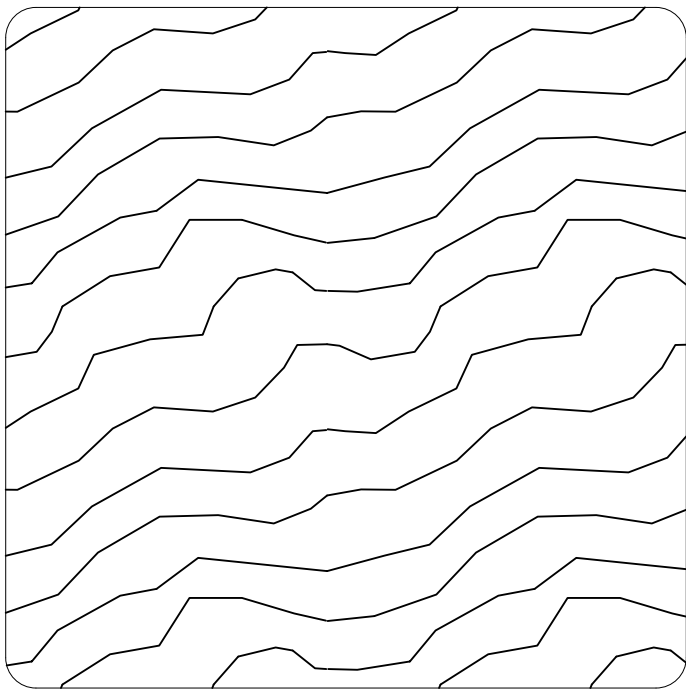
ST x1 00031

SF x1 00001

MG x2 00140

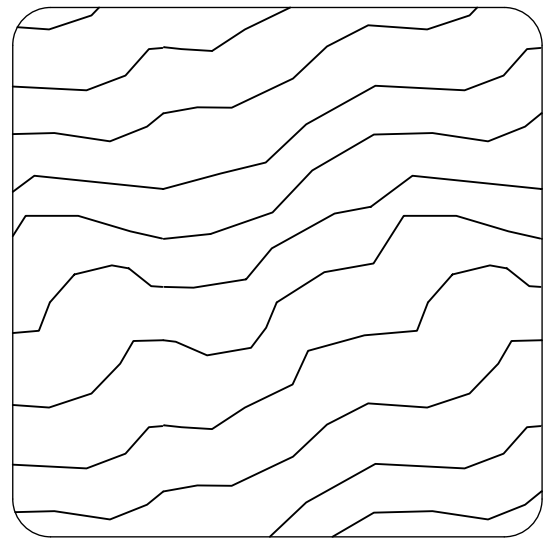



9,0 x 9,0 cm

Lp.	Kod	Wymiary [mm]	szt.
1a	06335	90x90x2400mm	1



7,0 x 7,0 cm

Lp.	Kod	Wymiary [mm]	szt.
2	04405	70x70x2400mm	2

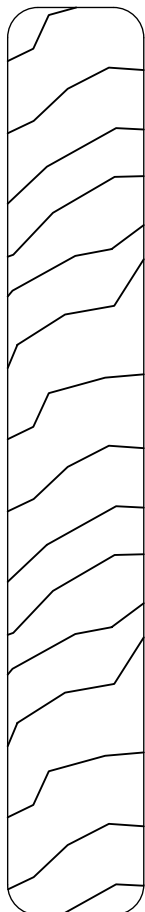

1,8 x 12,0 cm

Lp.	Kod	Wymiary [mm]	szt.
3	01418	18x120x1600mm	1
4a	00133	18x120x1500mm	1

1a

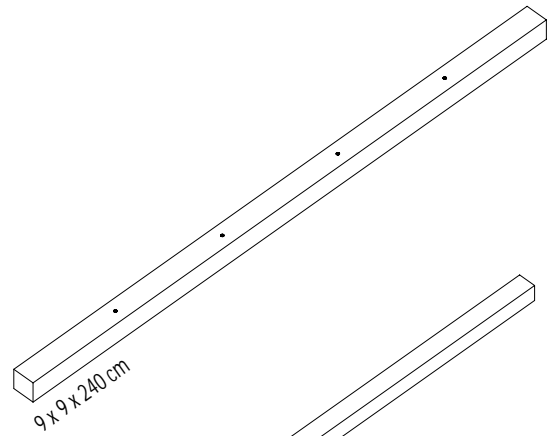

2

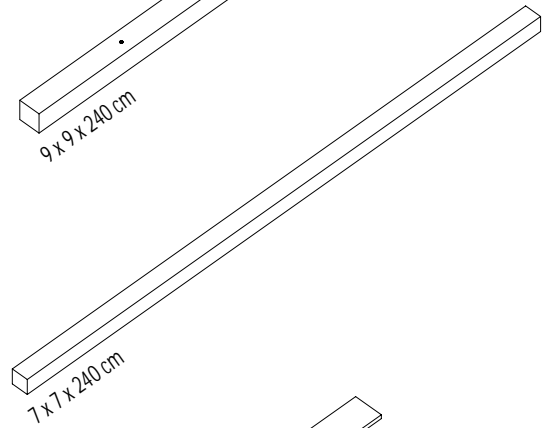

3

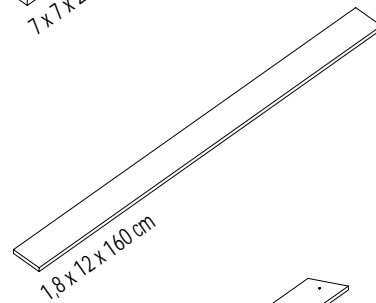

4a

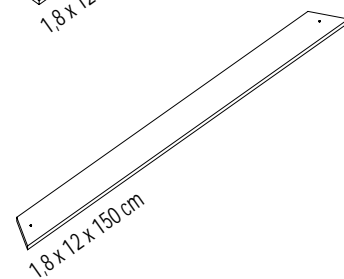

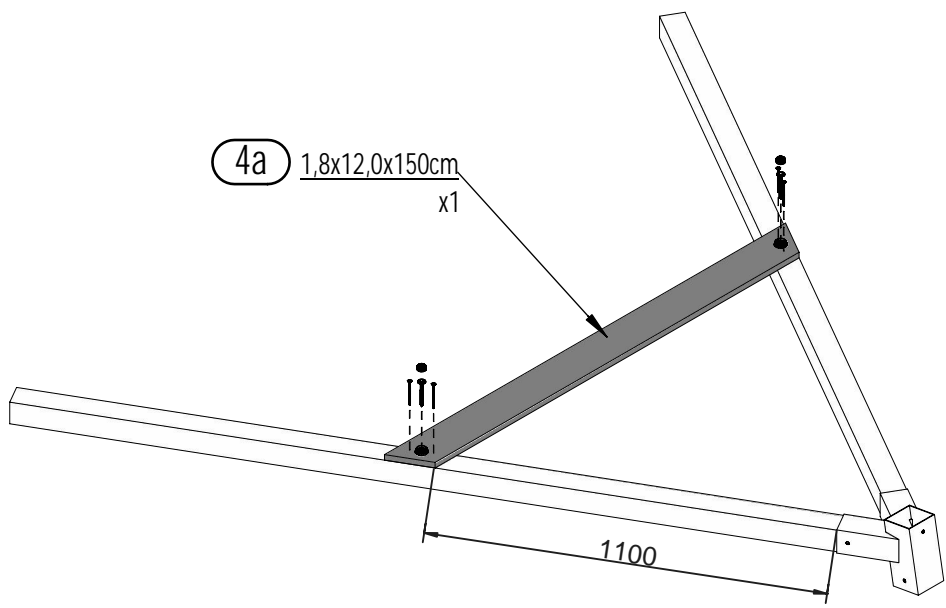
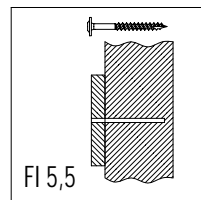
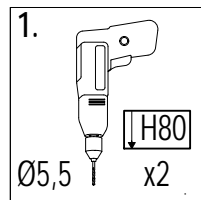
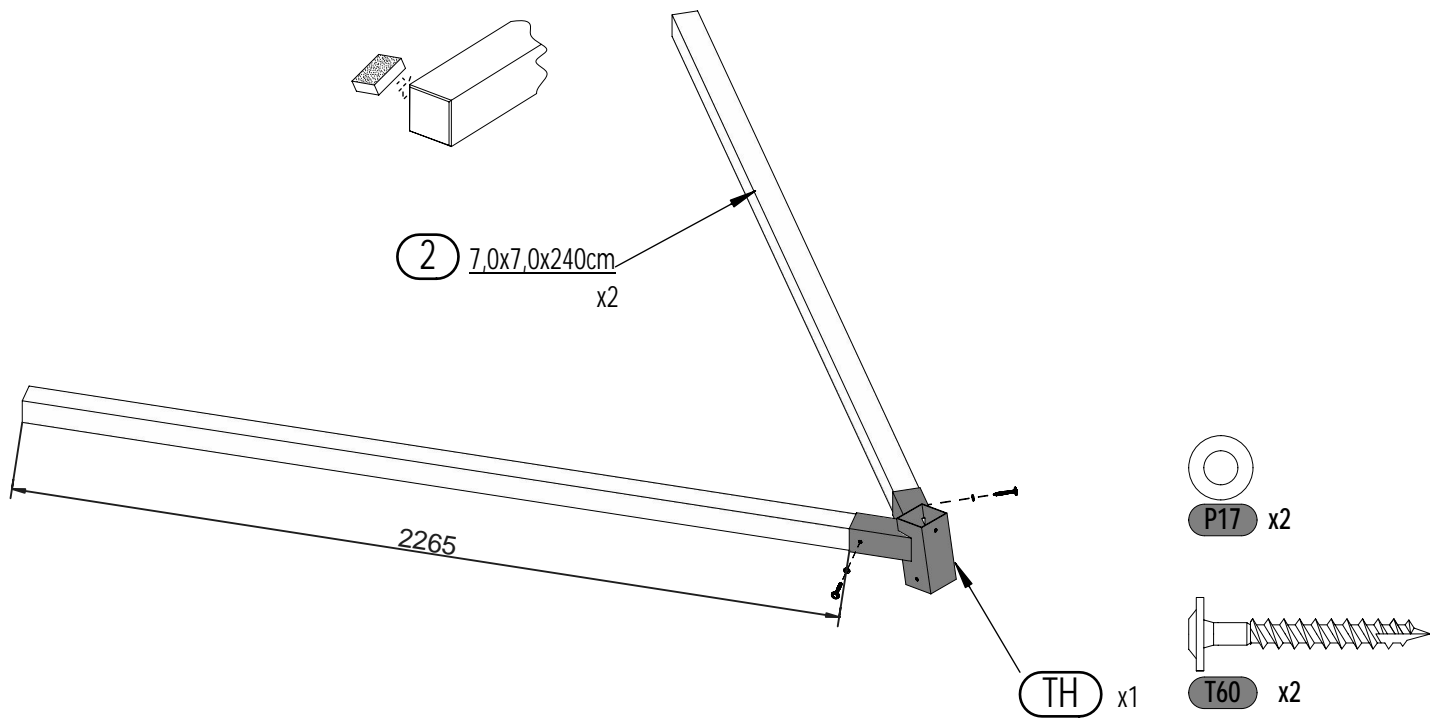

03

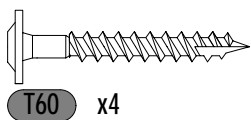
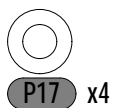
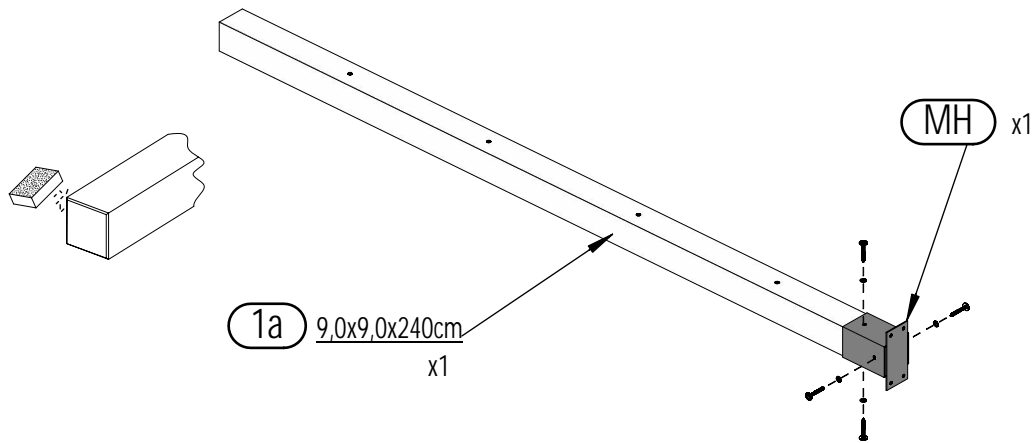

04

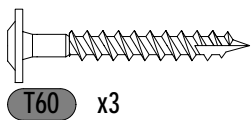
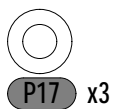
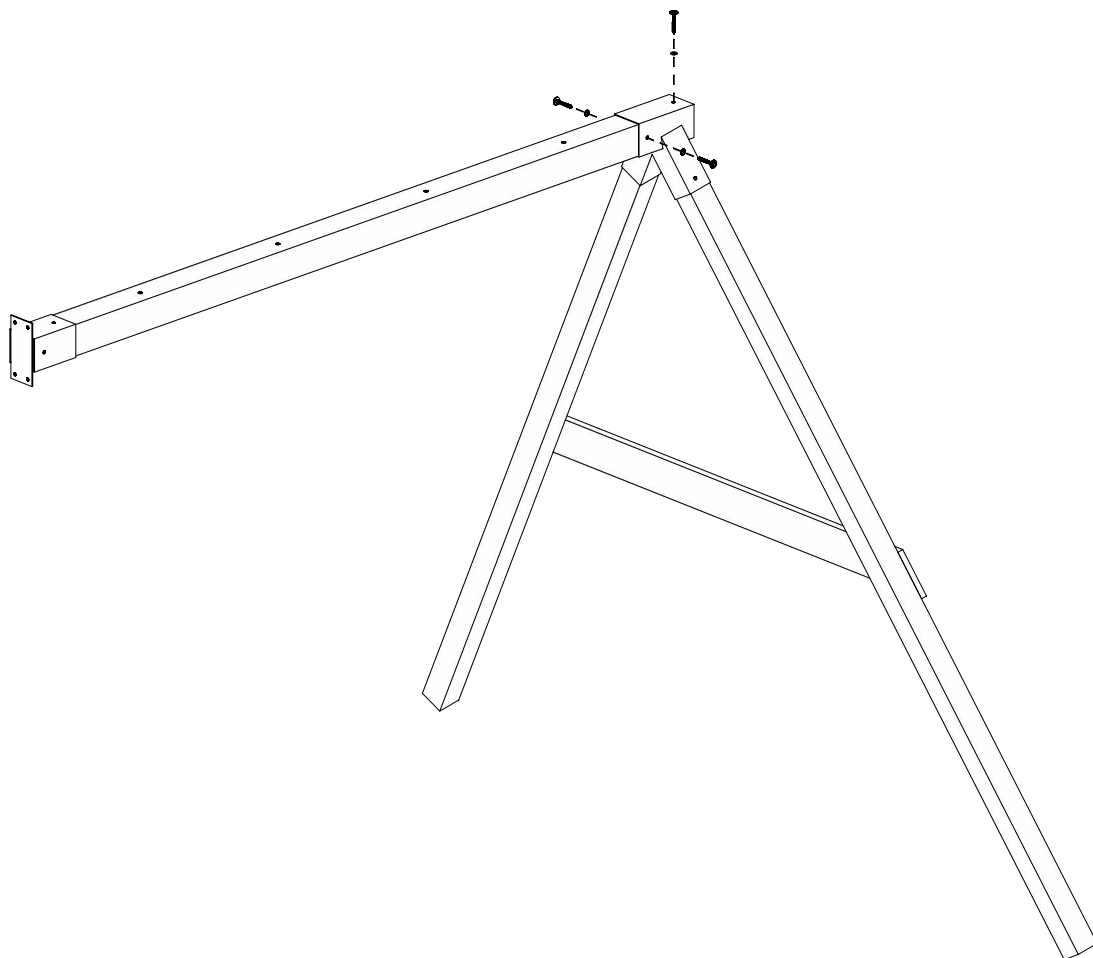

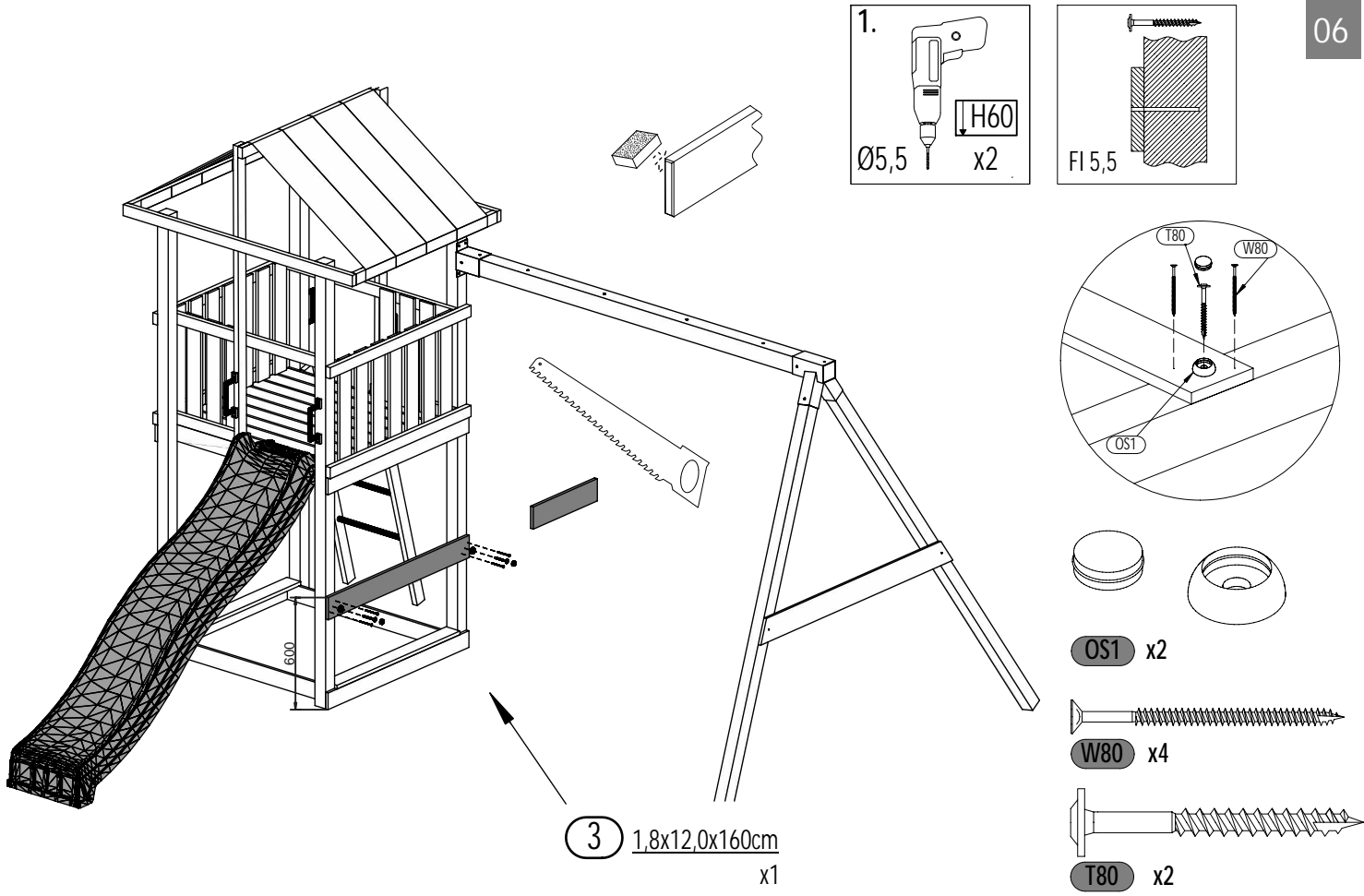
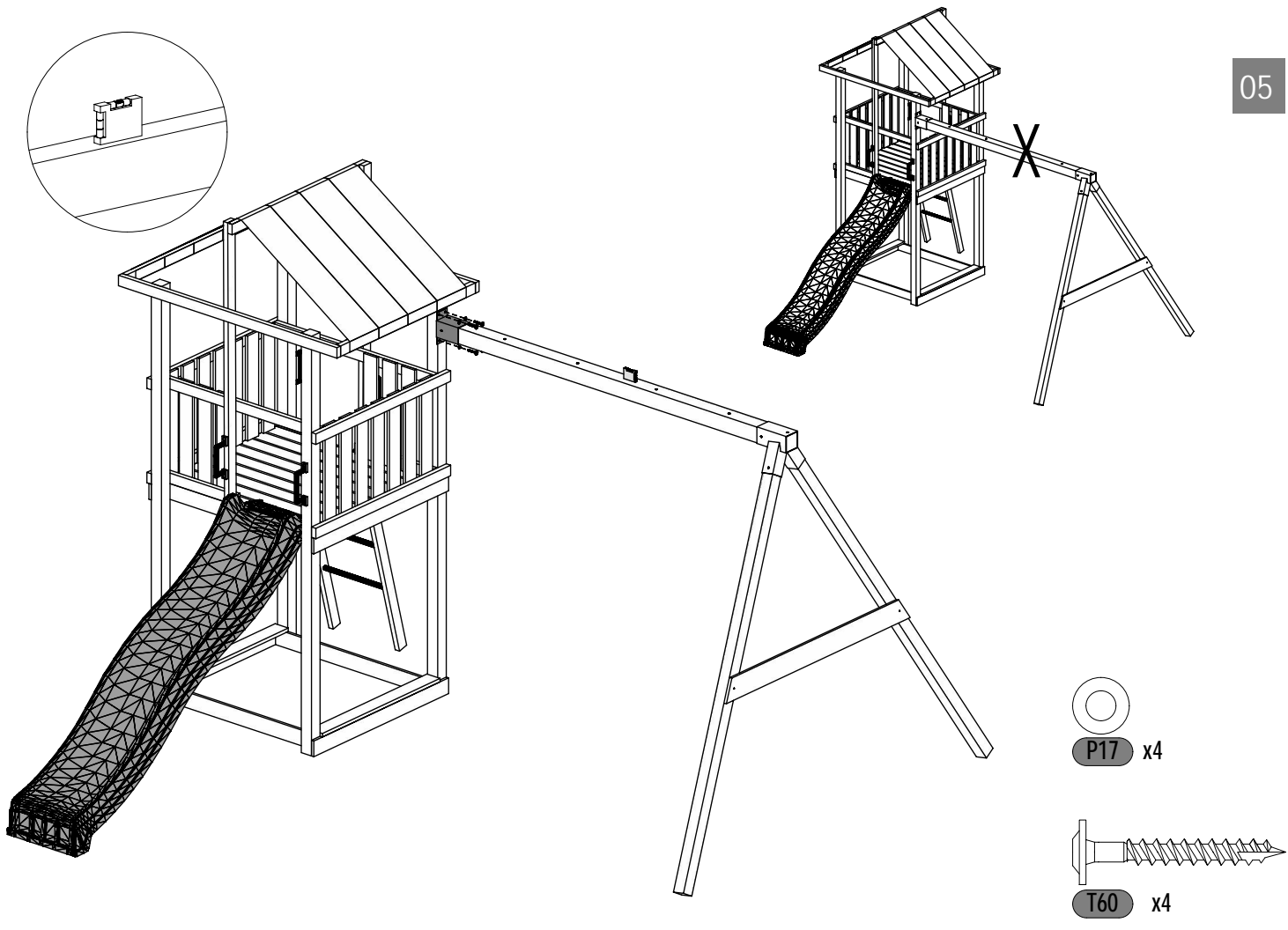

Zgodne z normą PN-EN 71 stosuj zalecenia producenta odnośnie odległości oraz metody mocowania poszczególnych elementów
 In compliance with the standard PN-EN 71, apply guidelines of the producer in relation to distances and methods of fastening individual elements

07

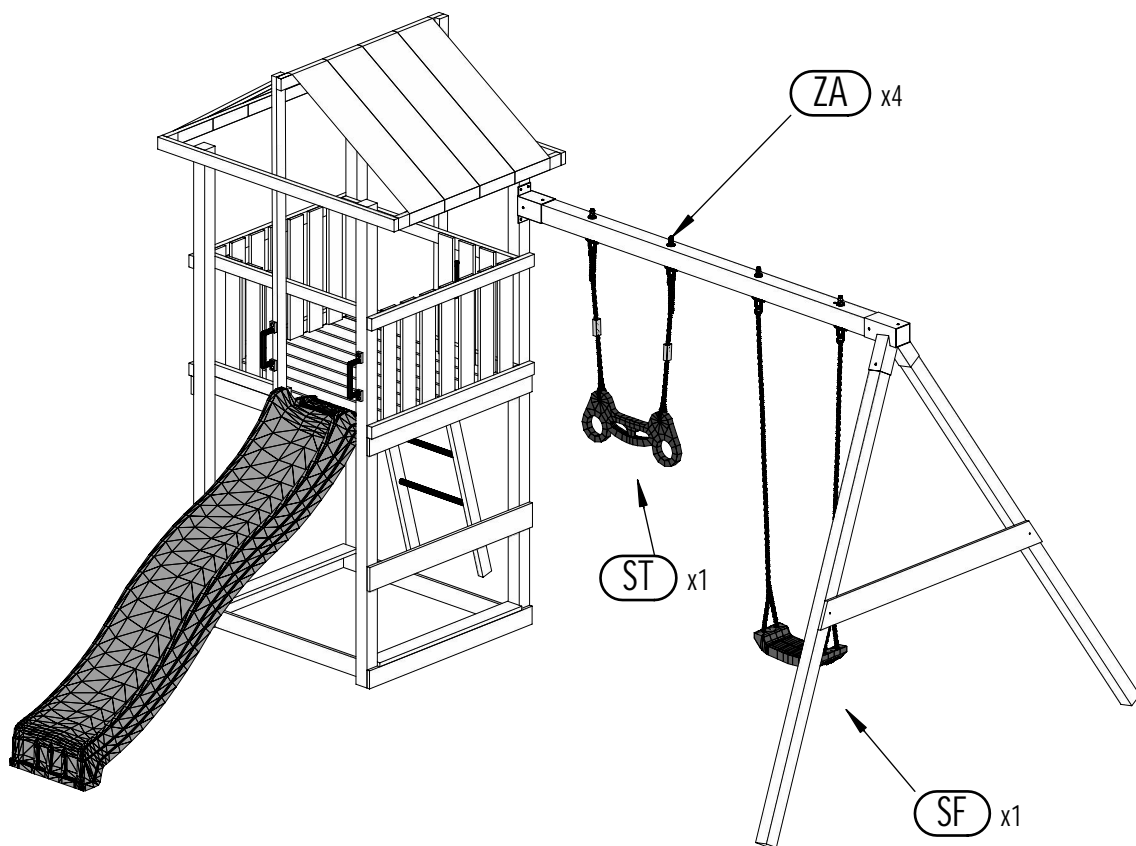

08

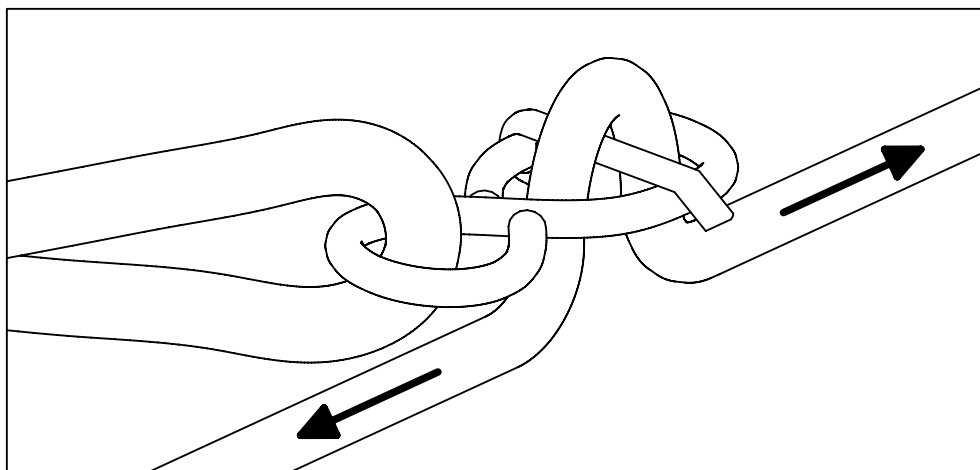

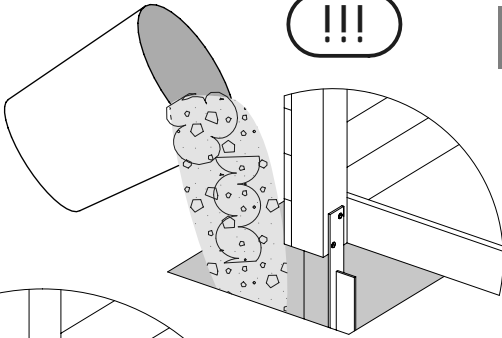
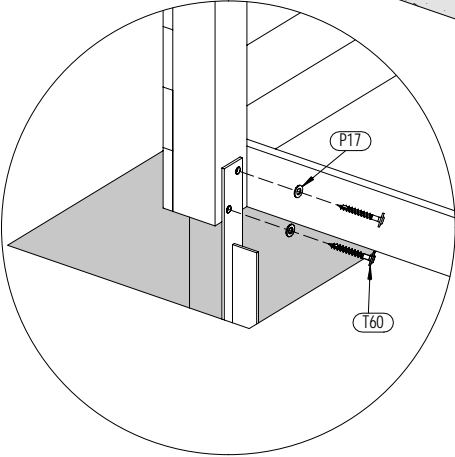
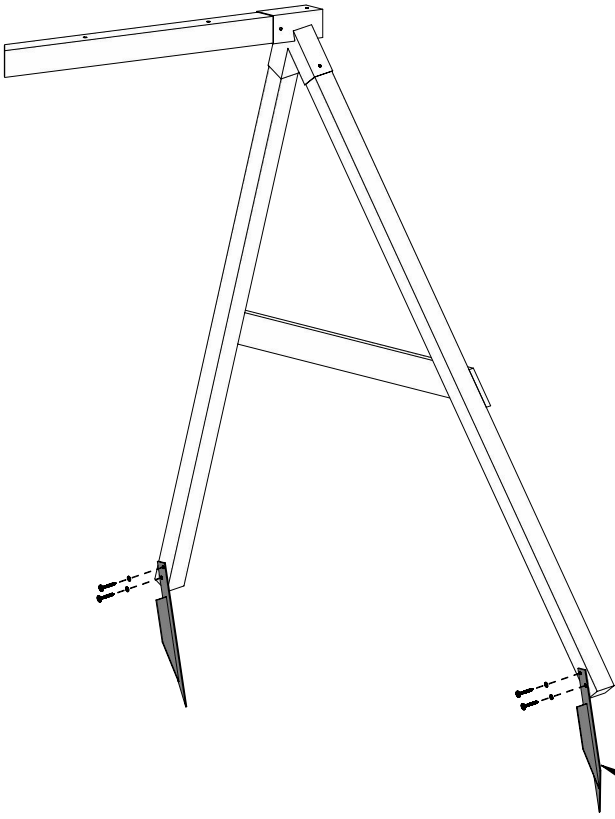

MG x2

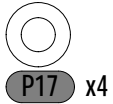

P17 x4

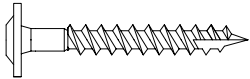

T60 x4

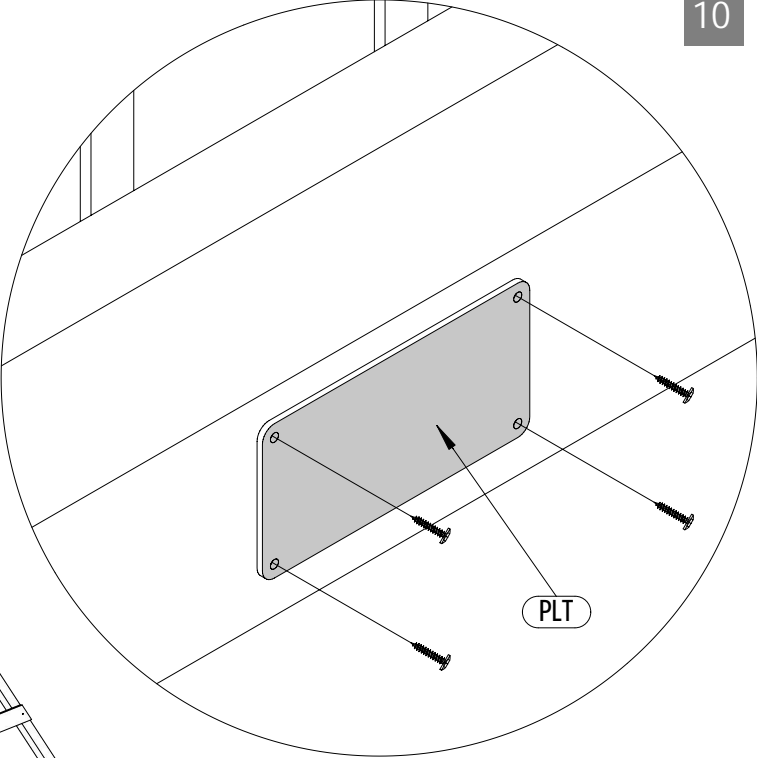
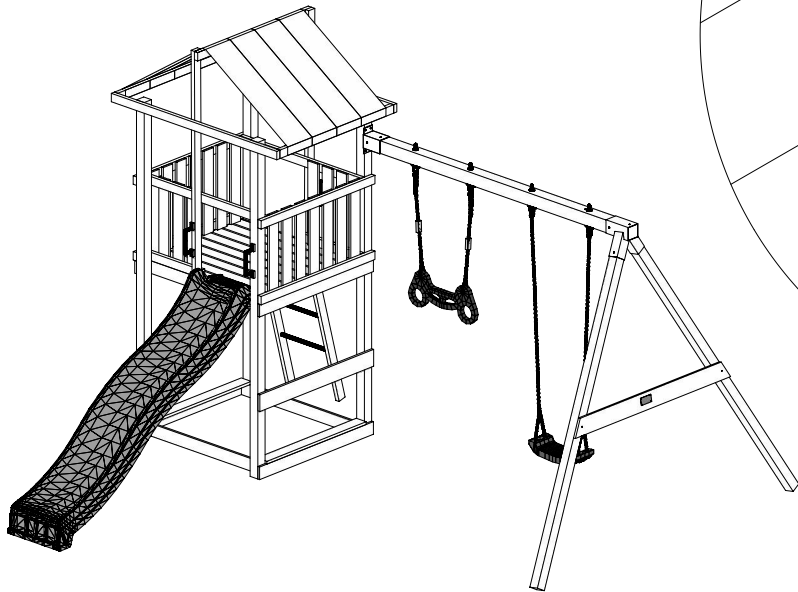

PLT



W20 x4

Zgodne z normą PN-EN 71 stosuj zalecenia producenta odnośnie odległości oraz metody mocowania poszczególnych elementów
In compliance with the standard PN-EN 71, apply guidelines of the producer in relation to distances and methods of fastening individual elements

SPEELPLEIN

BEACH MODULE

01220_01235_01245_01260_01270

01275_02460_02670

23082017

INSTALLATIE INSTRUCTIES

AIRE DE JEUX

BEACH MODULE

01220_01235_01245_01260_01270

01275_02460_02670

23082017

GUIDE D'INSTALLATION

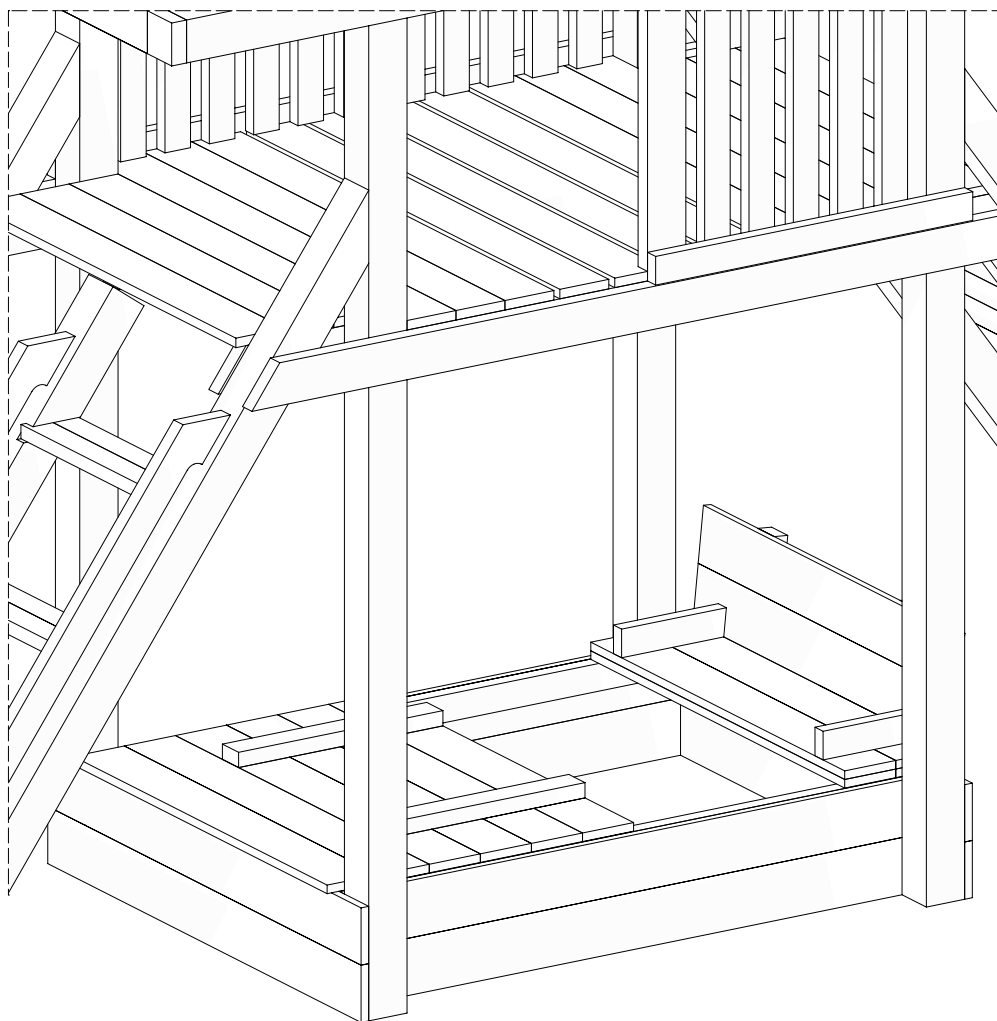

WAARSCHUWING!

Enkel voor gebruik thuis.

Enkel buitenshuis te gebruiken

Ontworpen voor kinderen van 3 jaar

Gevaar voor vallen en / of stoten

Maximum toegelaten gewicht is 50kg

Maximum aantal kinderen dat gelijktijdig

op het speeltuig kan staan is: 4.

AVERTISSEMENT!

Aire exclusivement destinée à un usage privé.

Aire exclusivement destinée à un usage en extérieur.

Prévue pour les enfants de plus de 3 ans.

Danger de chute ou de choc.

Poids maximal d'un utilisateur : 50 kg.

Nombre maximal d'utilisateurs présents en

même temps sur la même aire de jeux: 4.

W80



W40



	JUNIOR	SUN/ JOY	PARADISE/ FORTRESS	SHIP	ROCKET/ GIANT	KINGDOM	under Platform's	under House
	pcs	pcs	pcs	pcs	pcs	pcs	pcs	pcs
W80	16	0	5	0	0	0	16	16
W40	24	24	24	24	24	24	24	24

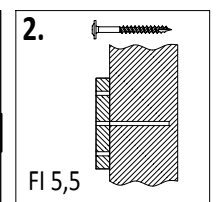
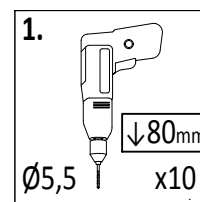
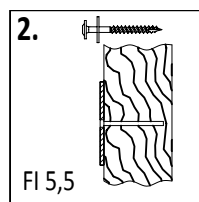
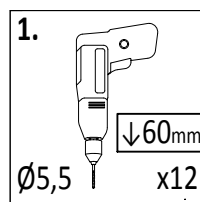
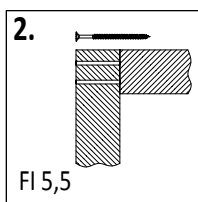
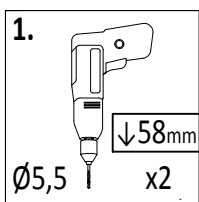
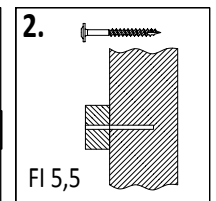
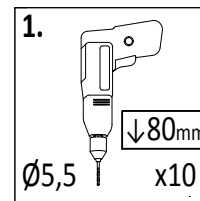
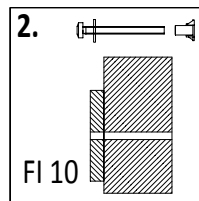
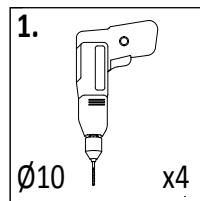
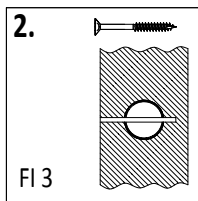
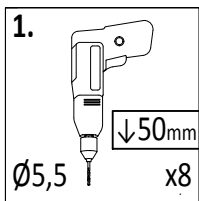
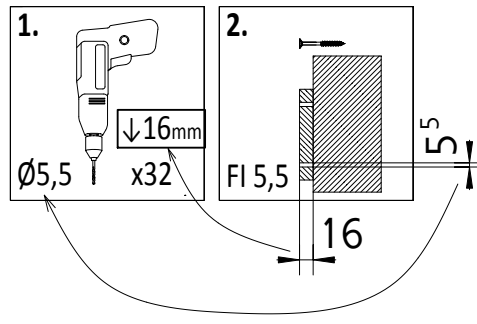
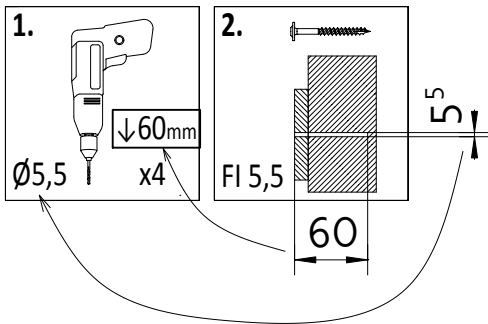

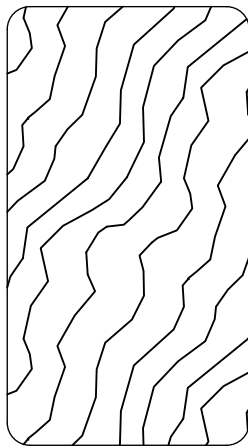
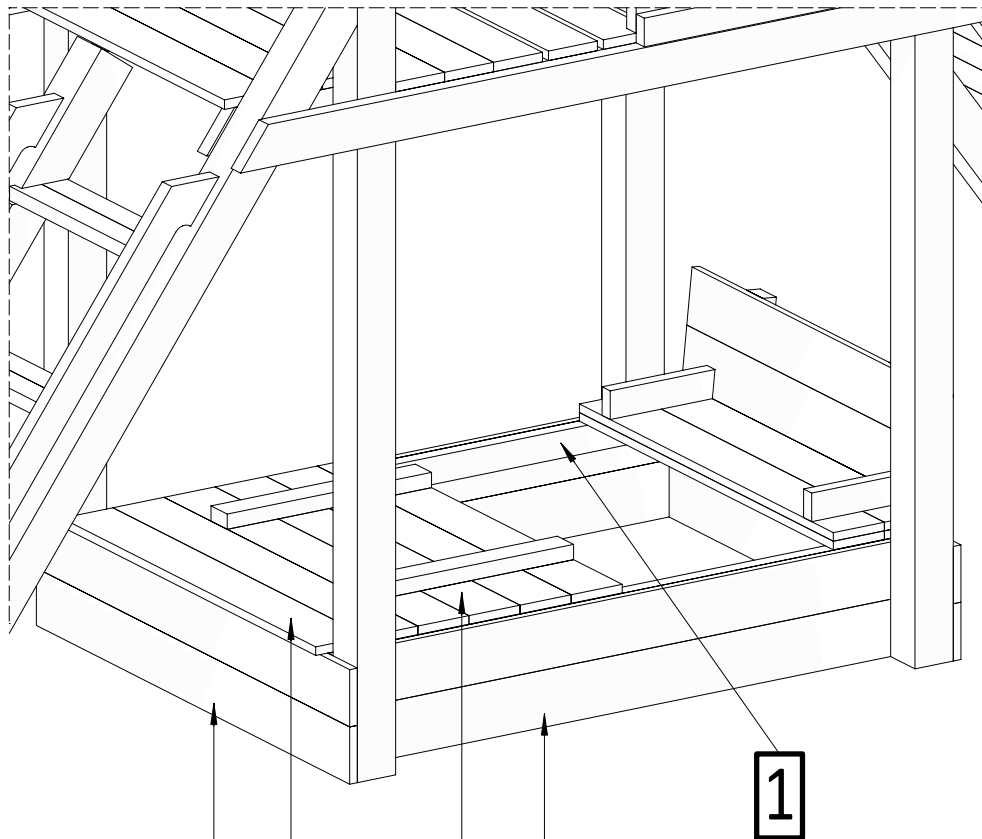

3,2 x 5,8 cm

2 **4** **KP** **3**

	JUNIOR	SUN/ JOY	PARADISE/ FORTRESS	SHIP	ROCKET/ GIANT	KINGDOM	under Platform's	under House
	cm x pcs	cm x pcs	cm x pcs	cm x pcs	cm x pcs	cm x pcs	cm x pcs	cm x pcs
1	105cm x 2pcs	120cm x 2pcs	130cm x 2pcs	160cm x 2pcs	140cm x 2pcs	150cm x 2pcs	120cm x 2pcs	120cm x 2pcs

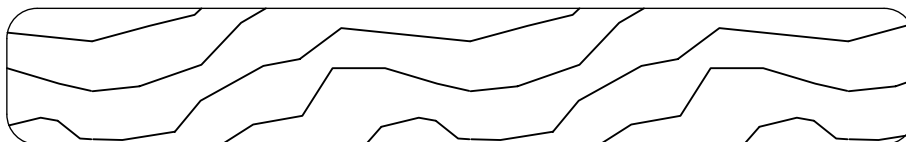
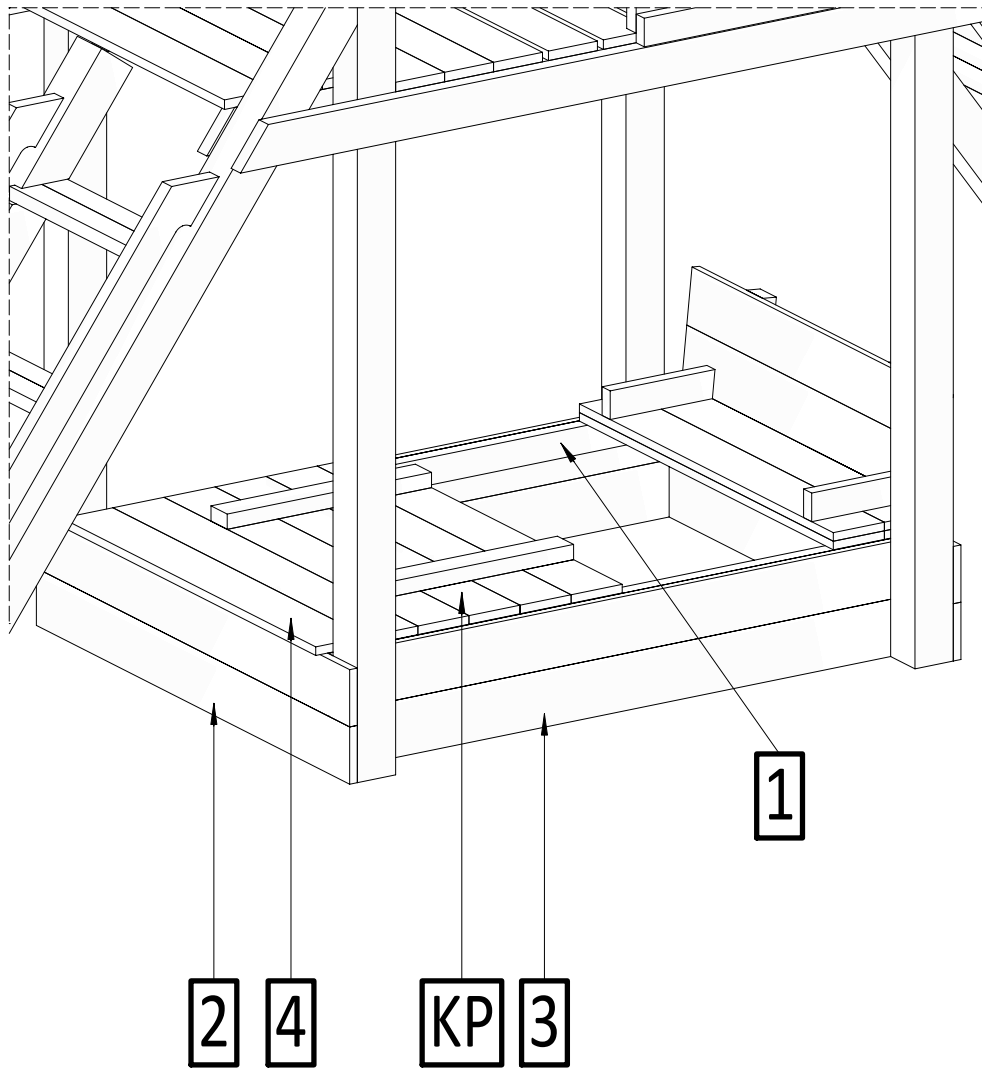

	JUNIOR	SUN/ JOY	PARADISE/ FORTRESS	SHIP	ROCKET/ GIANT	KINGDOM	under Platform's	under House
	cm x pcs	cm x pcs	cm x pcs	cm x pcs	cm x pcs	cm x pcs	cm x pcs	cm x pcs
2	105cm x 2pcs						120cm x 2pcs	134cm x 2pcs
3	105cm x 2pcs		130cm x 1pcs				120cm x 2pcs	120cm x 2pcs
4	87cm x 2pcs	102cm x 2pcs	126cm x 2pcs	138cm x 2pcs	94cm x 2pcs	88cm x 2pcs	102cm x 2pcs	116cm x 2pcs
KP	87x45cm x 2pcs	102x50cm x 2pcs	126x55cm x 2pcs	138x69cm x 2pcs	94x60cm x 2pcs	88x62,5cm x 2pcs	102x50cm x 2pcs	116x50cm x 2pcs

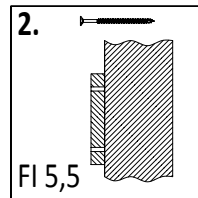
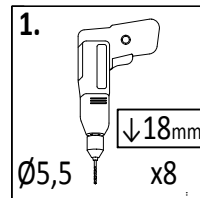
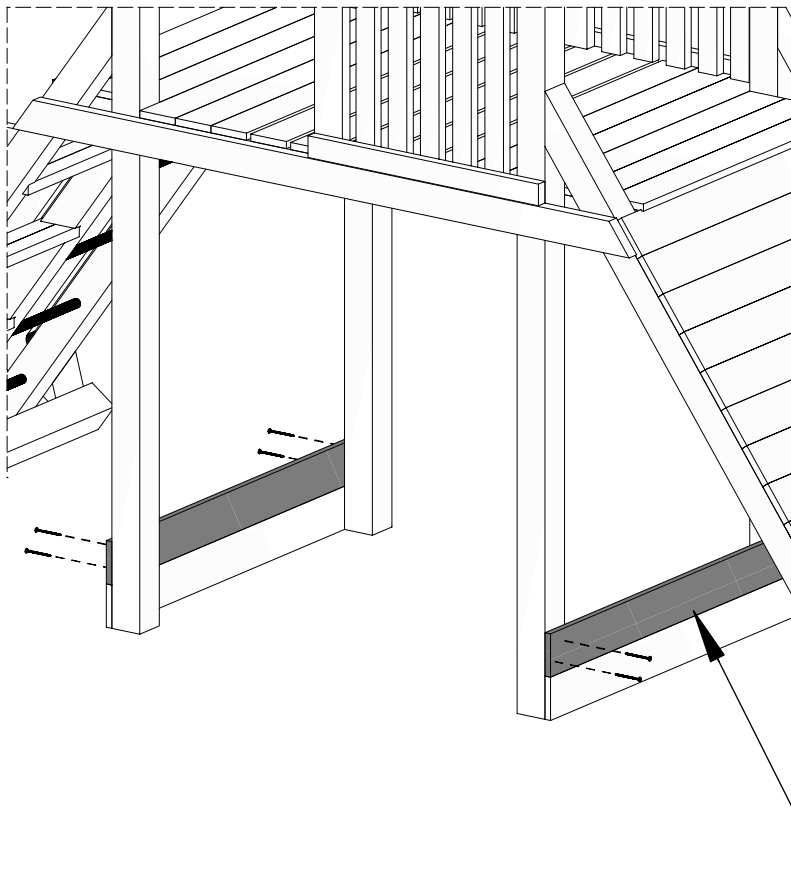

01

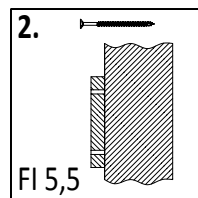
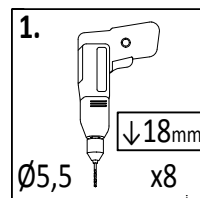
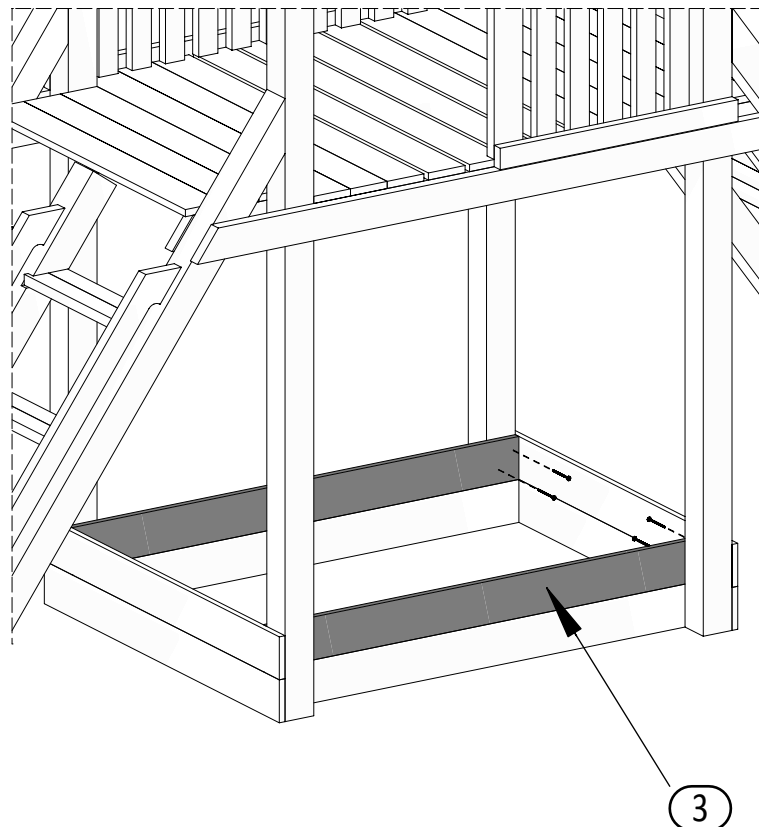

02

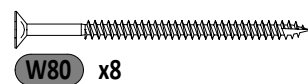

03



PARADISE FORTRESS

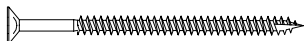
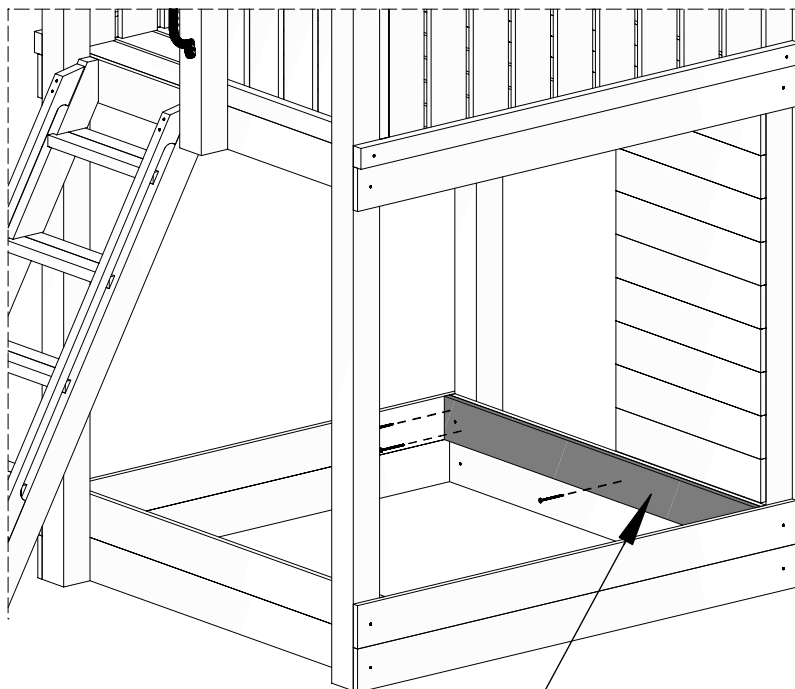
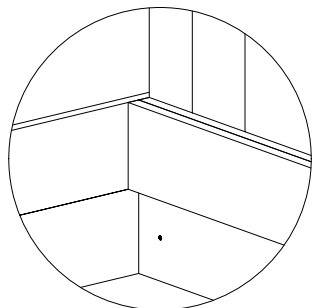

W80 x5

3 x1

04

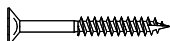
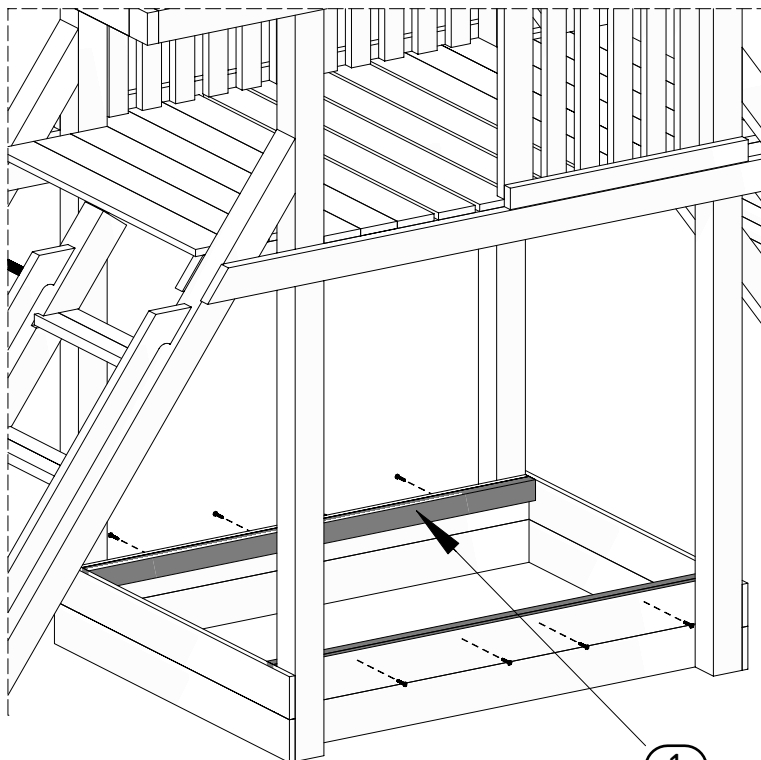
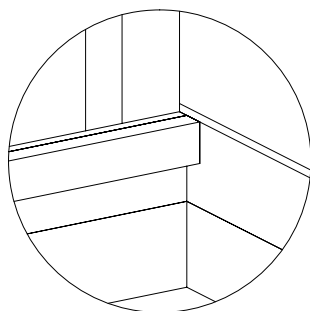

W40 x8

1 x2

6

BEACH

Zgodnie z normą PN-EN 71 stosuj zalecenia producenta odnośnie odległości oraz metody mocowania poszczególnych elementów
In compliance with the standard PN-EN 71, apply guidelines of the producer in relation to distances and methods of fastening individual elements

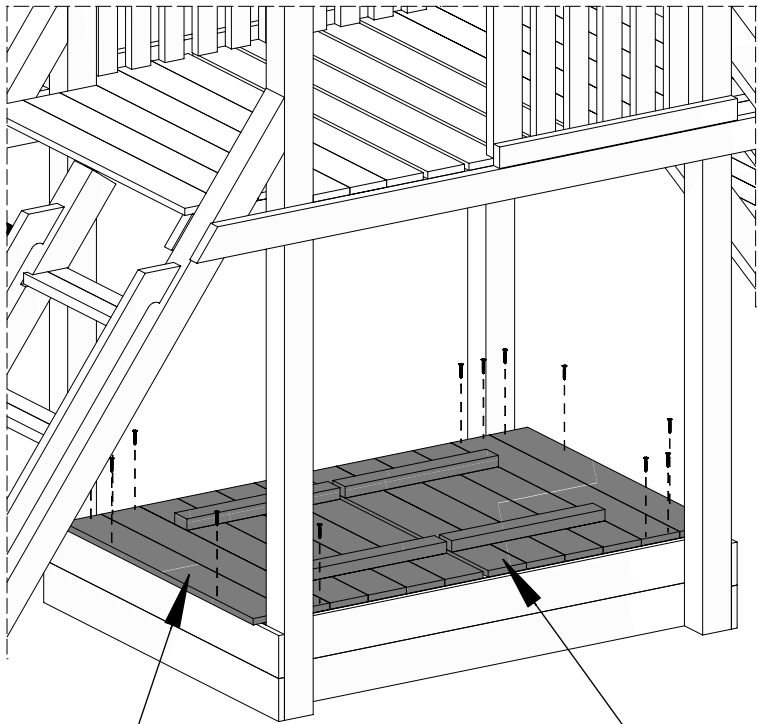
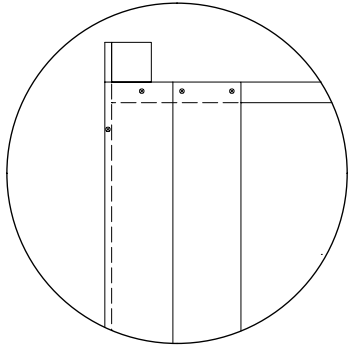
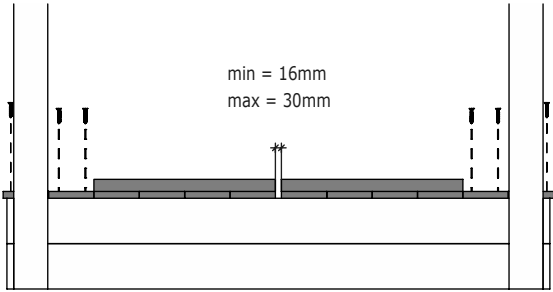
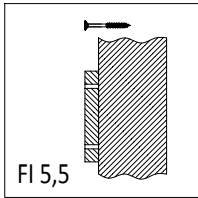
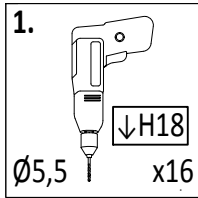

4 x2

KP x2

