

# PLAYGROUND SPIELPLATZ

# PLAC ZABAW AIRE DE JEUX BUFFALO

(302 x 335 x h285cm)

003\_03610\_16092022

INSTALLATION INSTRUCTIONS  
MONTAGEANLEITUNG

INSTRUKCJA MONTAŻU  
GUIDE D'INSTALLATION

Warranty period - 2 years from purchase date

Garantiezeit - 2 Jahre ab Kaufdatum

Okres gwarancji - 2 lata od momentu zakupu towaru

Période de garantie - 2 ans à compter de l'achat

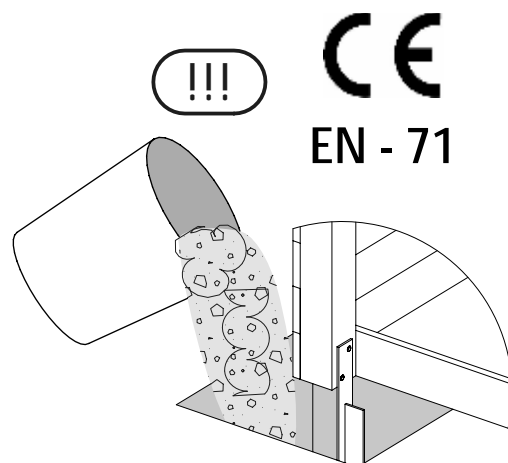
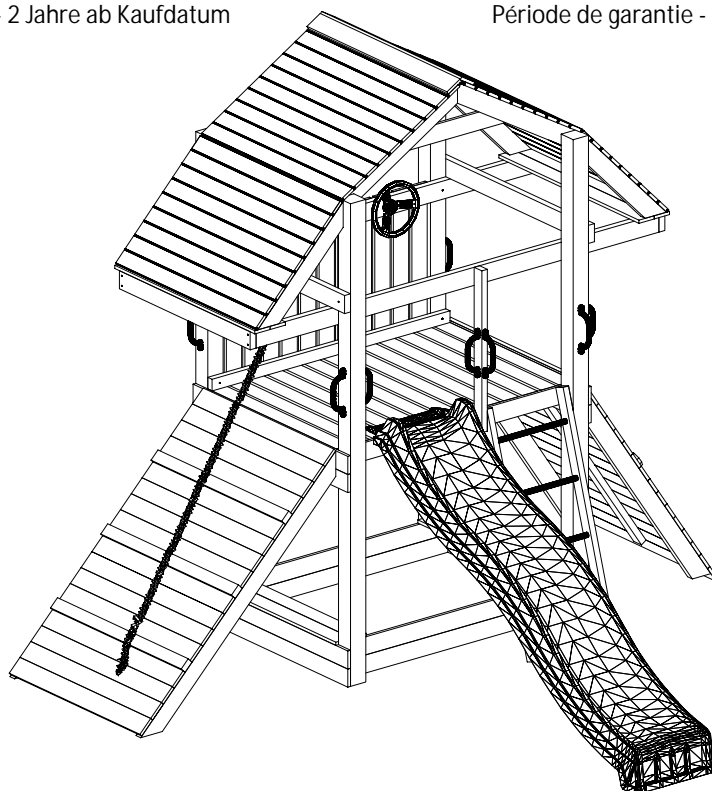

## WARNINGS!

Only for home use.

Dedicated for external use only.

Not suitable for children under 3 years old.

Risk of falling down and/or hitting.

Maximum user weight is up to 50 kg.

Maximum number of users staying on the playground at the same time: 7.

## OSTRZEŻENIA!

Tylko do użytku domowego.

Przeznaczony do użytku na zewnątrz.

Nie przeznaczony dla dzieci poniżej 3 roku życia.

Niebezpieczeństwo upadku i/lub uderzenia.

Maksymalna waga użytkownika to 50 kg.

Maksymalna liczba użytkowników przebywających na placu zabaw w tym samym czasie: 7.

## ACHTUNG!

Nur für den privaten, häuslichen Bereich.

Ausschließlich für die Verwendung im Freien.

Nicht geeignet für Kinder unter 3 Jahren.

Stolper- und / oder Sturzgefahr

Höchstgewicht pro Einzelkind beträgt 50 kg

Der Aufenthalt auf diesem Spielturm ist max. : 7.

Kindern gleichzeitig erlaubt.

## AVERTISSEMENT!

Aire exclusivement destinée à un usage privé.

Aire exclusivement destinée à un usage en extérieur.

Prévue pour les enfants de plus de 3 ans.

Danger de chute ou de choc.

Poids maximal d'un utilisateur : 50 kg.

Nombre maximal d'utilisateurs présents en même temps sur la même aire de jeux: 7.

W80 x122  
+1 Gratis



P17 x17

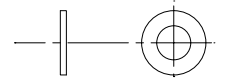

W40 x485  
+5 Gratis



P15 x20

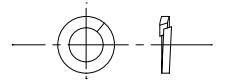

W30 x2

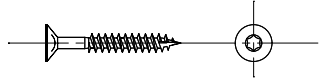

OS1 x33

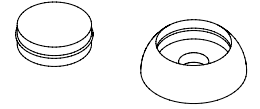

+2 Gratis

W20 x6

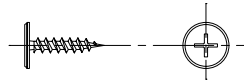

T120 x4

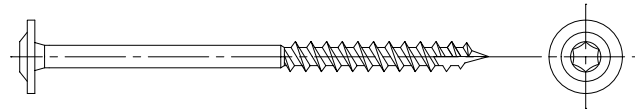

T80 x31



T60 x24

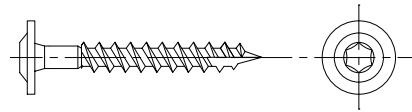

S50 x4

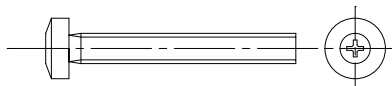

S40 x4

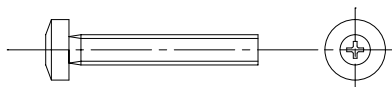

S30 x20

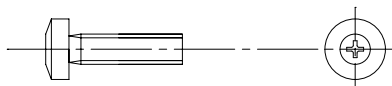

Ø3  
00239  
x1

Ø5,5  
01372  
x1

Ø10  
00188  
x1

L11 x27

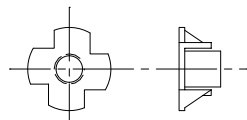

NS x1



PH3  
00068  
x1

PZ2  
00241  
x1

TX25  
00190  
x1

TX30  
00316  
x1

TX40  
00242  
x1

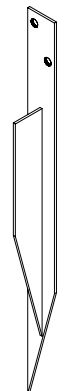
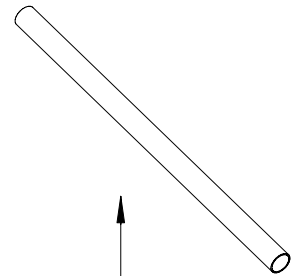
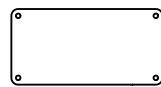
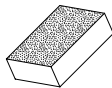
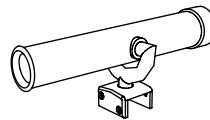
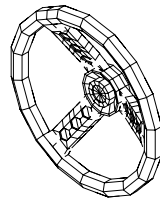
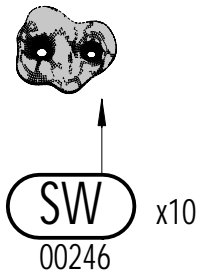
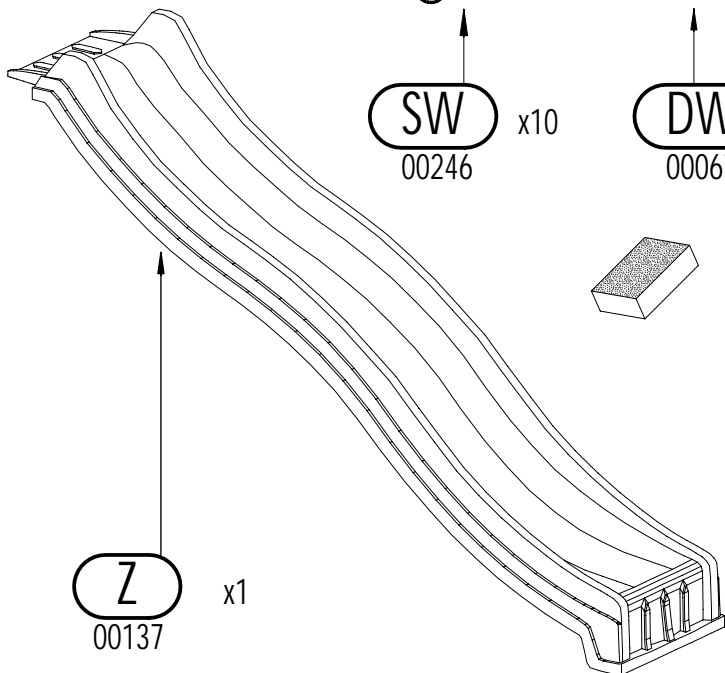
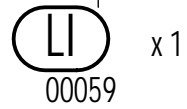
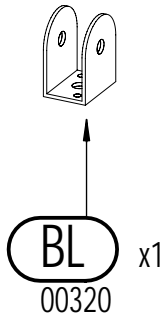
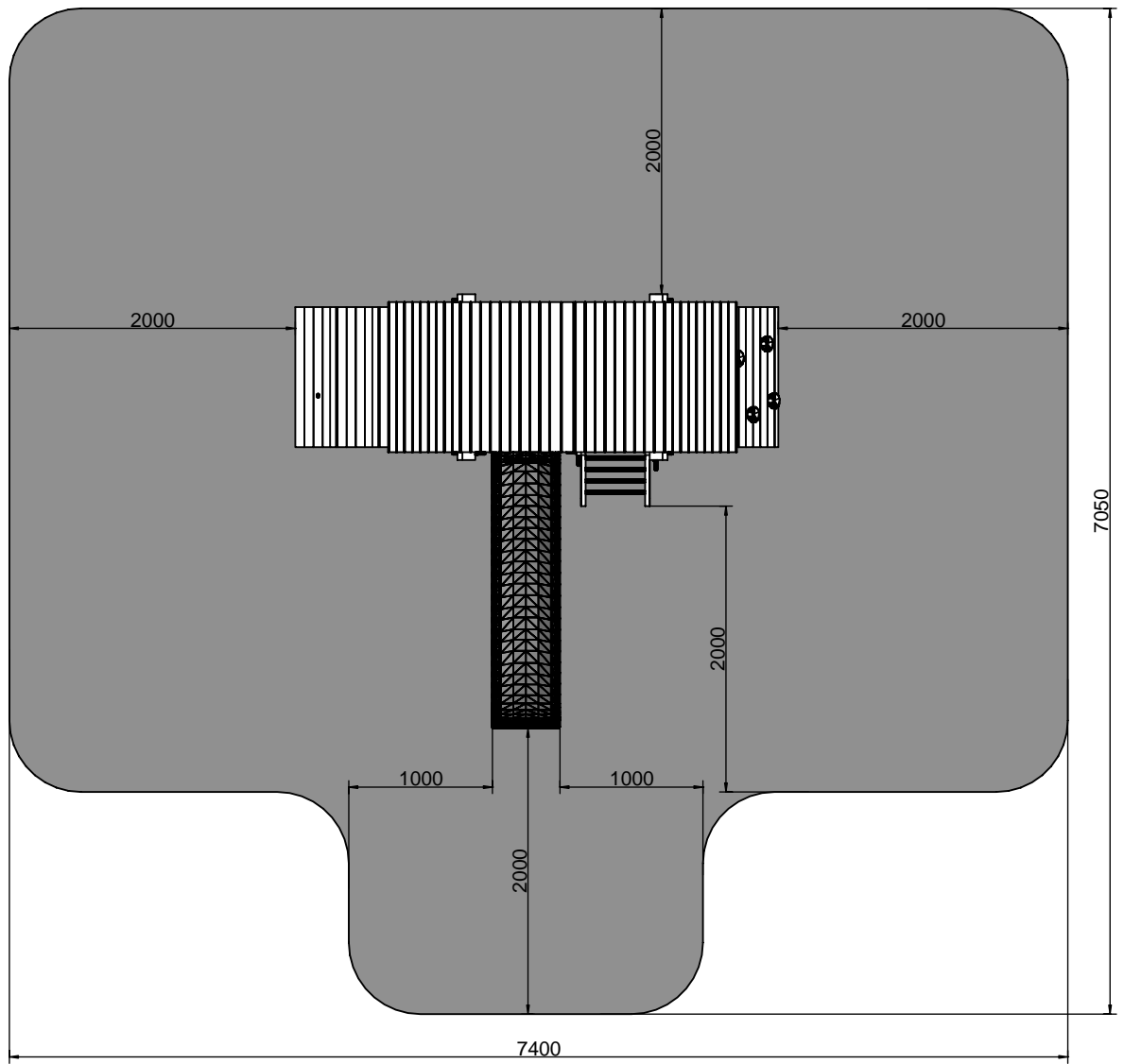

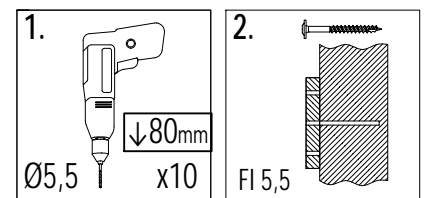
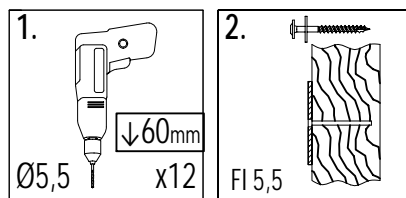
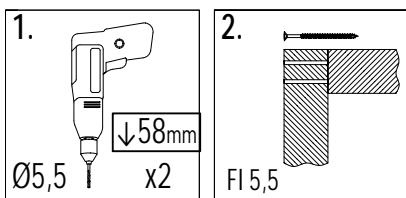
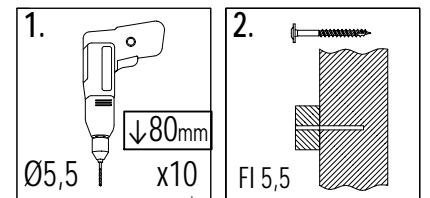
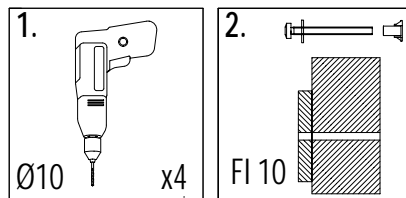
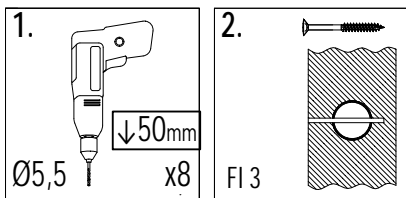
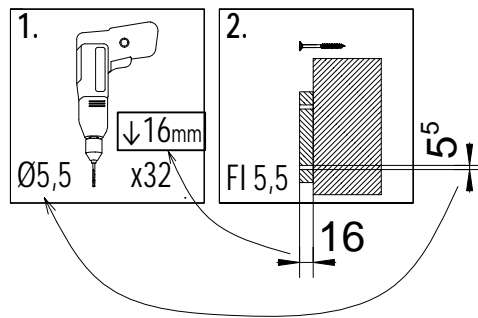
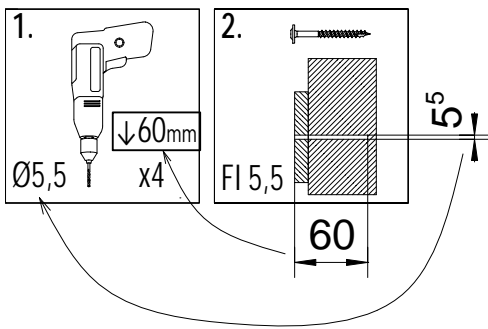
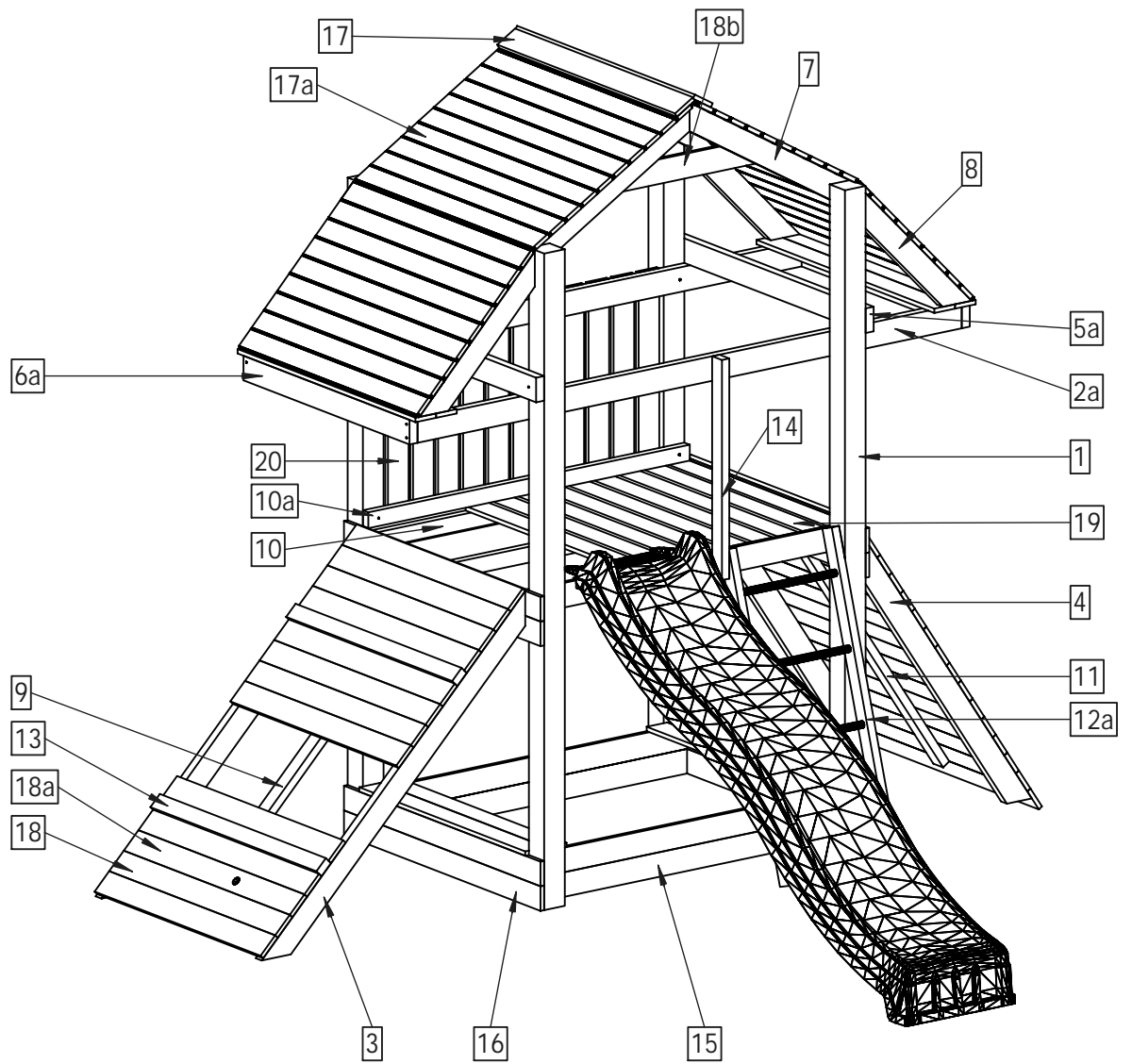

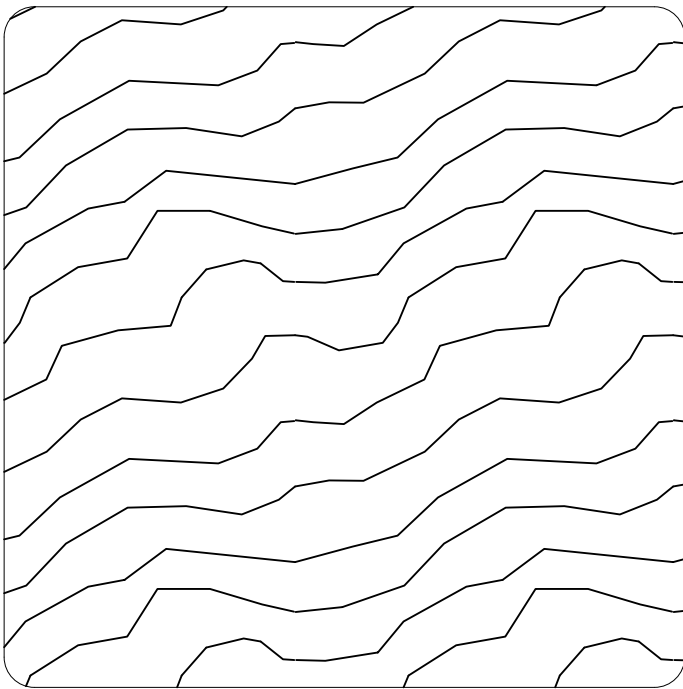

- **9 x 9 cm**

Lp.	Kod	Wymiary [mm]	szt.
1	05762	90x90x2400mm	4

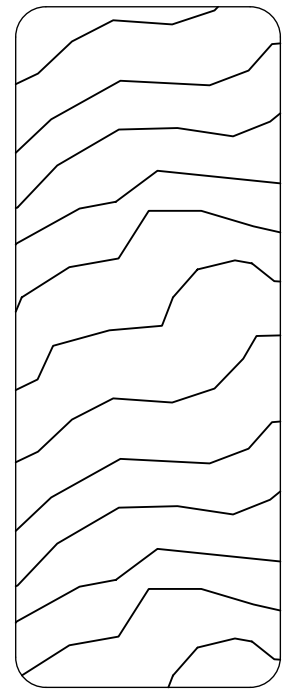

- **3,5 x 9,0 cm**

Lp.	Kod	Wymiary [mm]	szt.
2a	06403	35x90x2370mm	2
3a	06841	35x90x1625mm	2
4a	06843	35x90x1385mm	2
5a	00429	35x90x1160mm	2
6a	00674	35x90x980mm	2
7a	06845	35x90x863mm	4
8a	06847	35x90x720mm	4

- **1,6 x 9,0 cm**

Lp.	Kod	Wymiary [mm]	szt.
17a	02683	16x90x1050mm	40

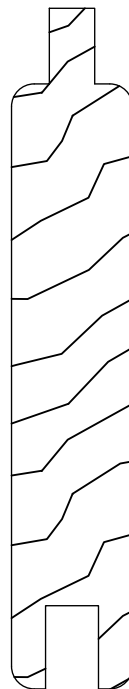

- **1,6 x 9,0 cm**

Lp.	Kod	Wymiary [mm]	szt.
15	06851	16x90x1400mm	6
16	00716	16x90x1160mm	8
17	02770	16x90x1050mm	6
18	02686	16x90x980mm	35
18a	02688	16x90x980mm	1
18b	06853	16x90x980mm	2
19	02692	16x90x948mm	13
20	02694	16x90x715mm	11

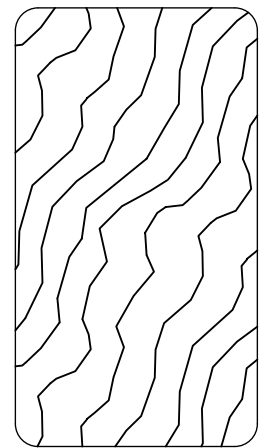
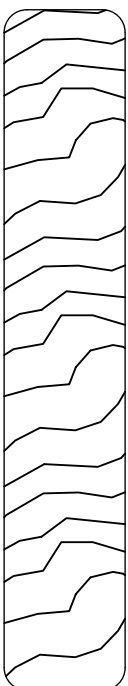

- **3,2 x 5,8 cm**

Lp.	Kod	Wymiary [mm]	szt.
9	06849	32x58x1520mm	1
10	05719	32x58x1400mm	3
10a	00903	32x58x1400mm	1
11	05243	32x58x1300mm	1
12a	02961	32x58x1200mm	2
13	00710	32x58x980mm	3
14	01503	32x58x800mm	1

1

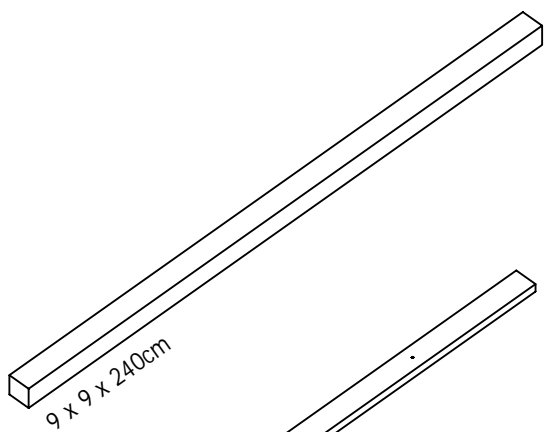

9 x 9 x 240cm

2a

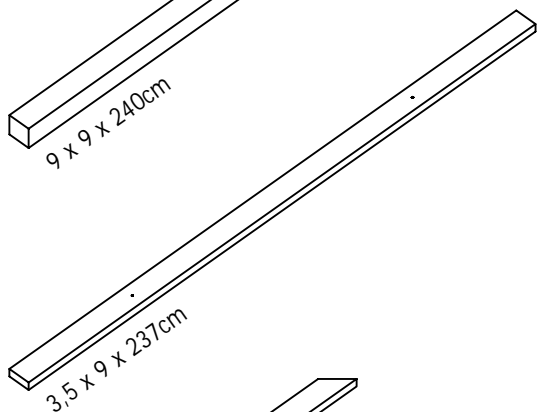

3,5 x 9 x 237cm

3

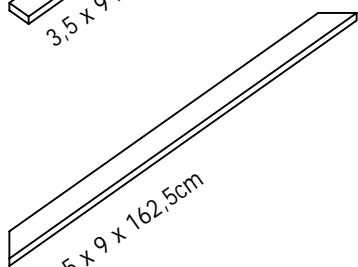

3,5 x 9 x 162,5cm

4

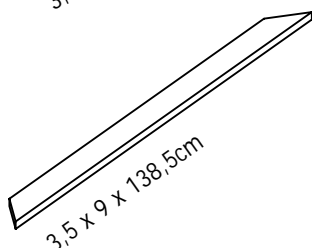

3,5 x 9 x 138,5cm

5a

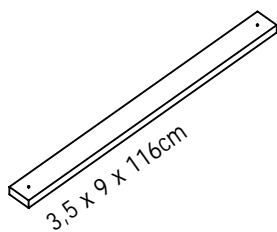

3,5 x 9 x 116cm

6a

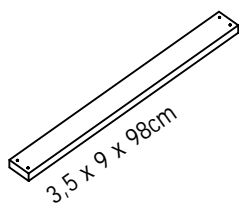

3,5 x 9 x 98cm

7

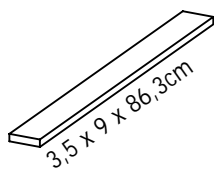

3,5 x 9 x 86,3cm

8

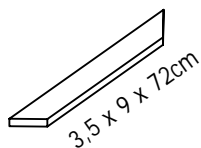

3,5 x 9 x 72cm

9

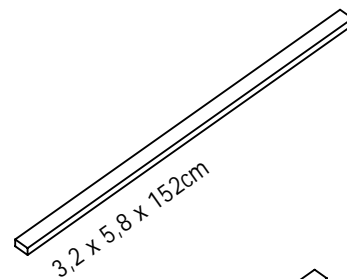

3,2 x 5,8 x 152cm

10

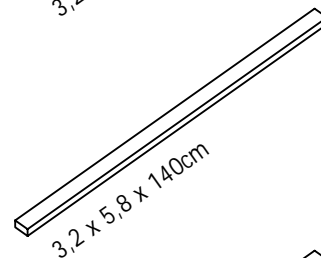

3,2 x 5,8 x 140cm

10a

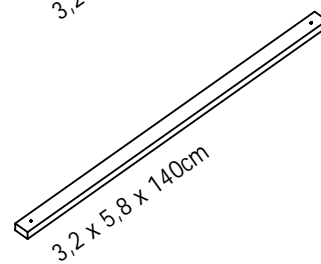

3,2 x 5,8 x 140cm

11

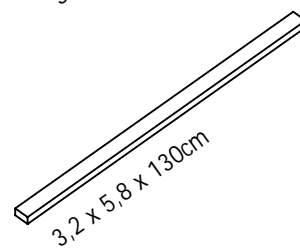

3,2 x 5,8 x 130cm

12a

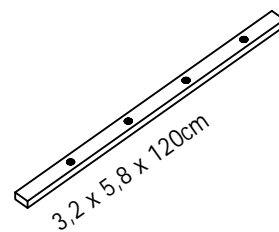

3,2 x 5,8 x 120cm

13

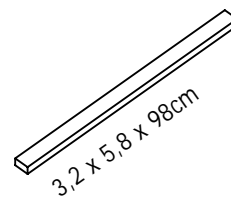

3,2 x 5,8 x 98cm

14

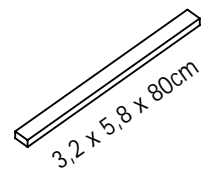

3,2 x 5,8 x 80cm

15

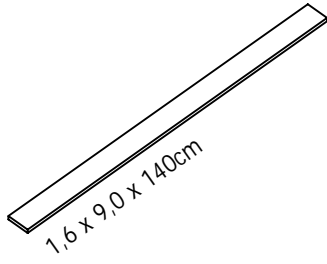

16

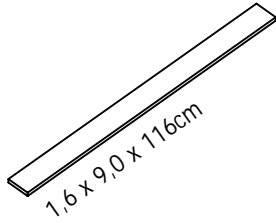

17

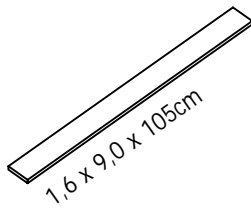

17a

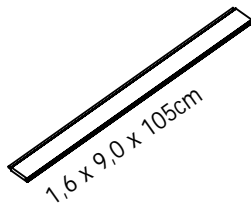

18

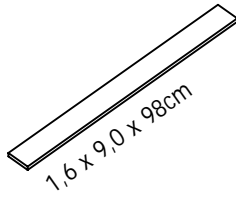

18a

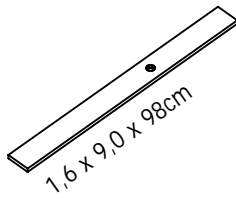

18b

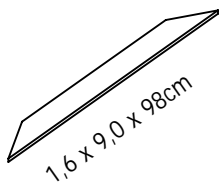

19

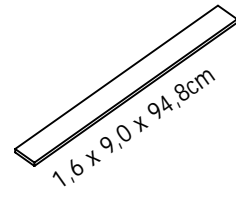

20

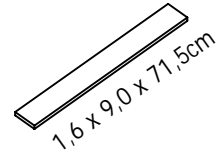

01

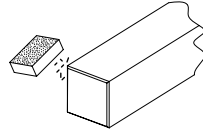
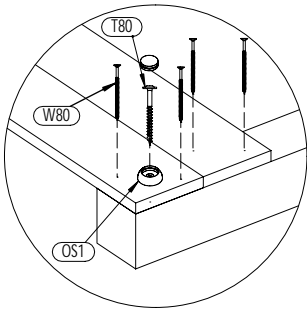
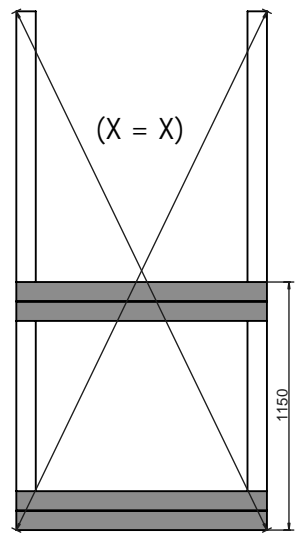
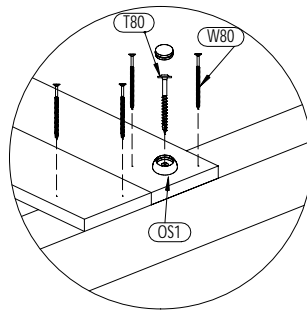
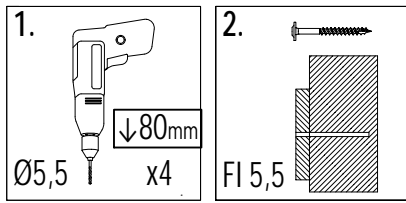

1 9,0x9,0x240cm  
x2

16 1,6x9,0x116cm  
x4

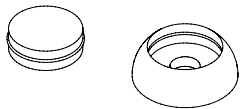
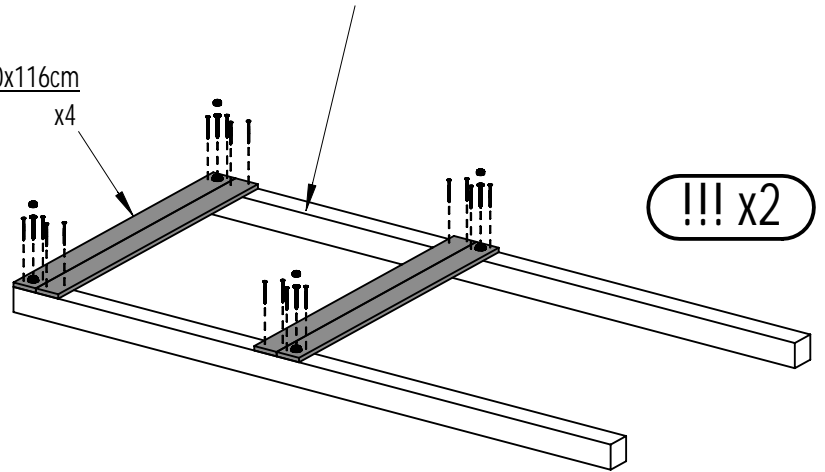

OS1 x4\*2 = 8

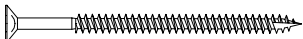

W80 x16\*2 = 32

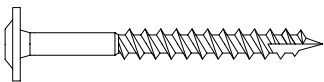

T80 x4\*2 = 8

02

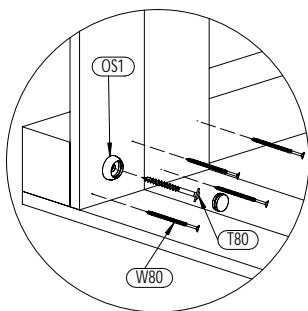
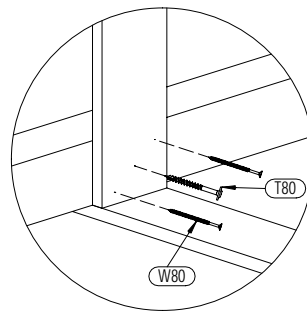
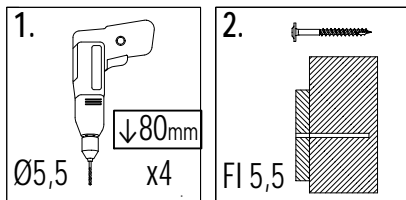

15 1,6x9,0x140cm  
x6

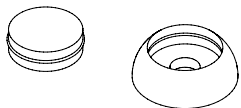
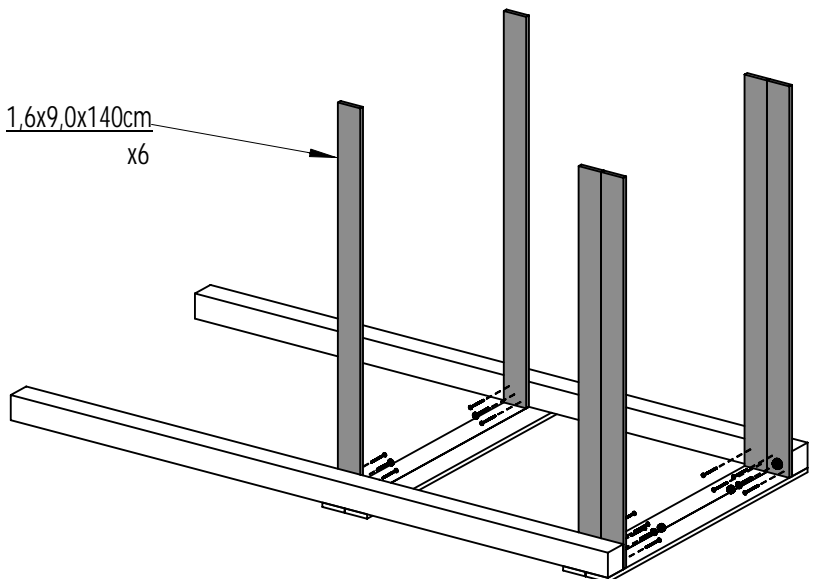

OS1 x2



W80 x12

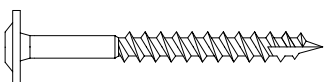

T80 x4



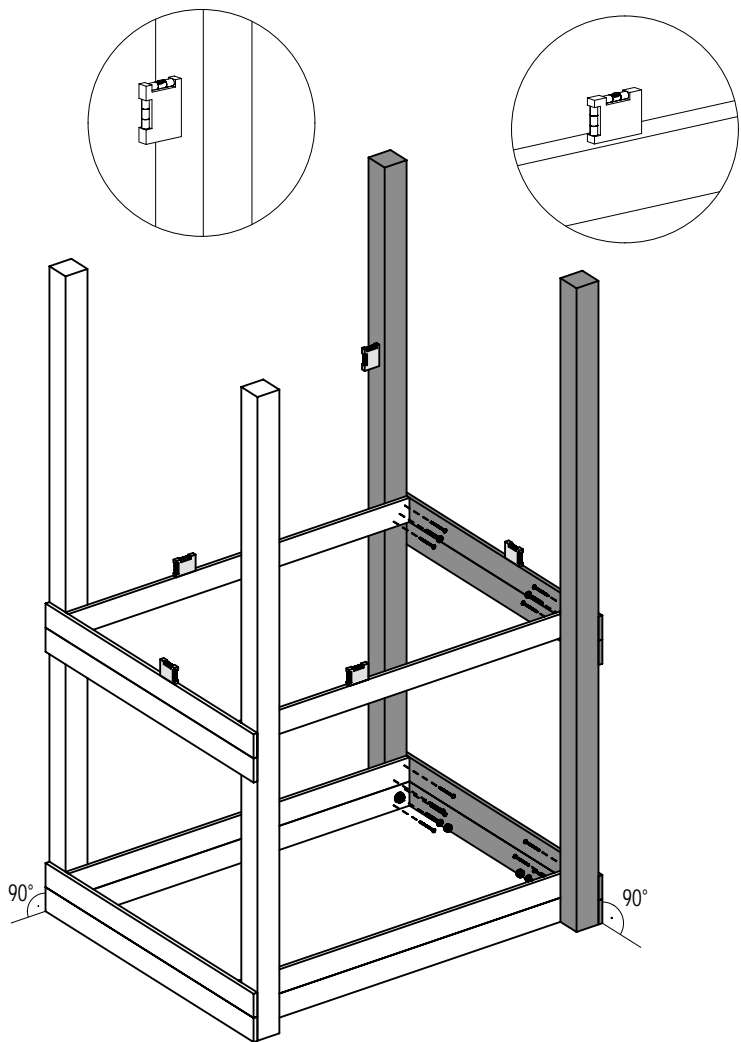

1.  $\downarrow 80\text{mm}$   
 $\varnothing 5,5$  x4

2.  $\downarrow$   
 FI 5,5

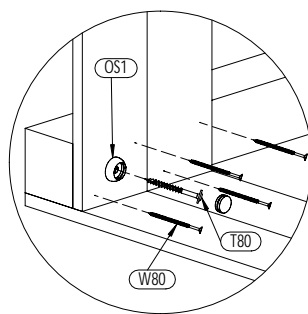
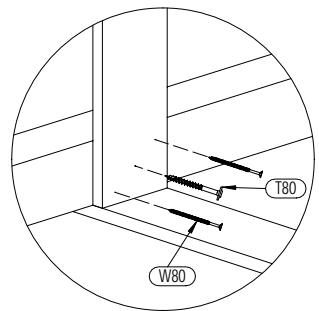

- OS1 x2
- W80 x12
- T80 x4

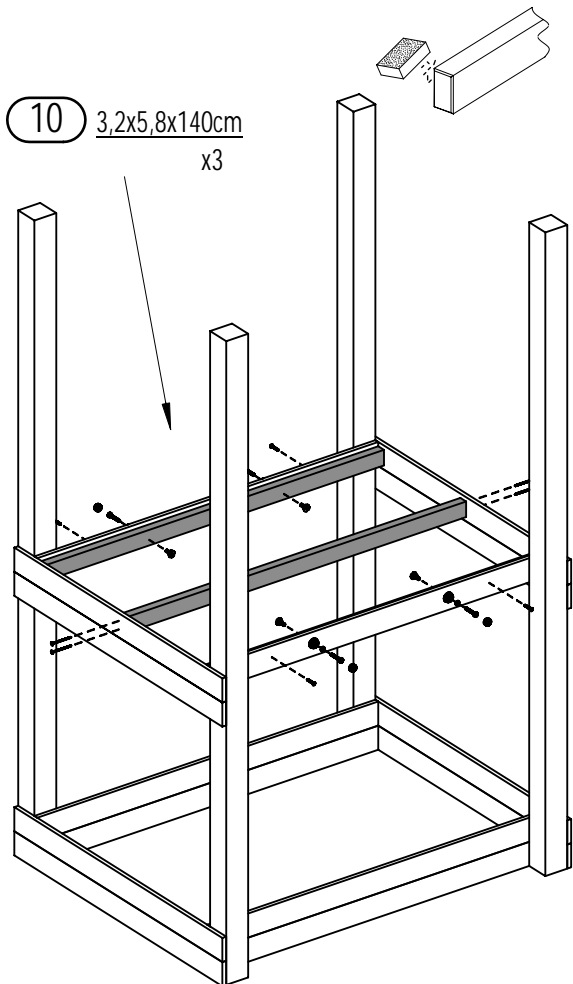

10 3,2x5,8x140cm  
x3

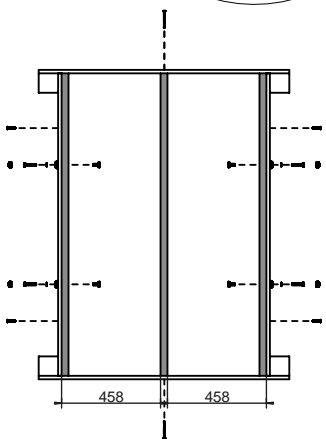
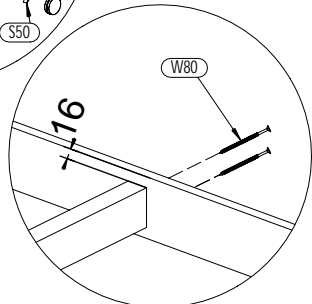
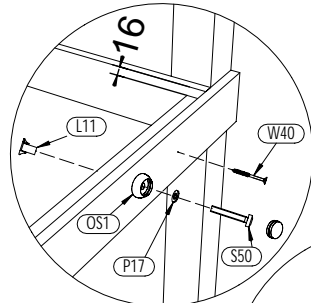

1.  $\downarrow$   
 $\varnothing 10$  x4

2.  $\downarrow$   
 FI 10

- OS1 x4
- W40 x4
- S50 x4
- P17 x4
- L11 x4
- W80 x4

Zgodne z normą PN-EN 71 stosuj zalecenia producenta odnośnie odległości oraz metody mocowania poszczególnych elementów  
 In compliance with the standard PN-EN 71, apply guidelines of the producer in relation to distances and methods of fastening individual elements

05

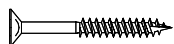
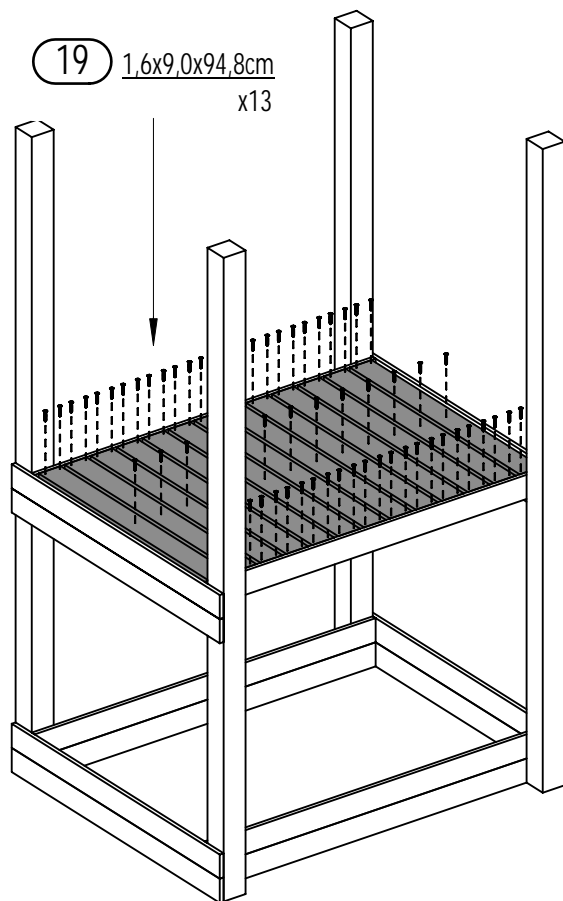
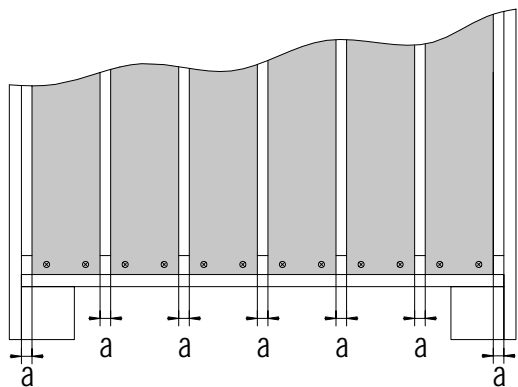
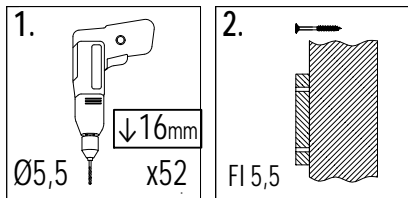

W40 x65

06

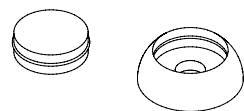
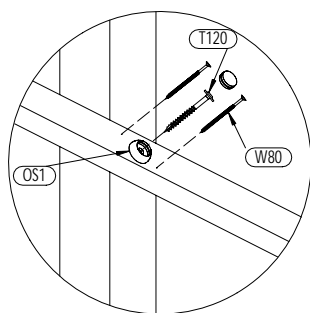
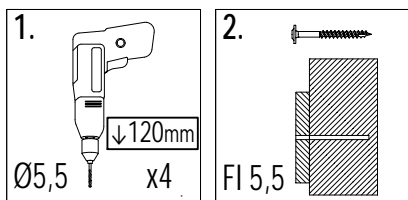

OS1 x4

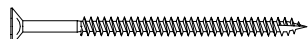

W80 x8

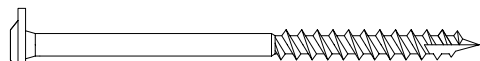

T120 x4

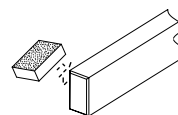
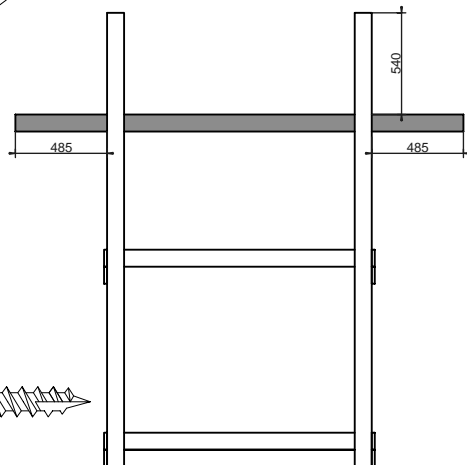

2a 3,5x9,0x237cm x2

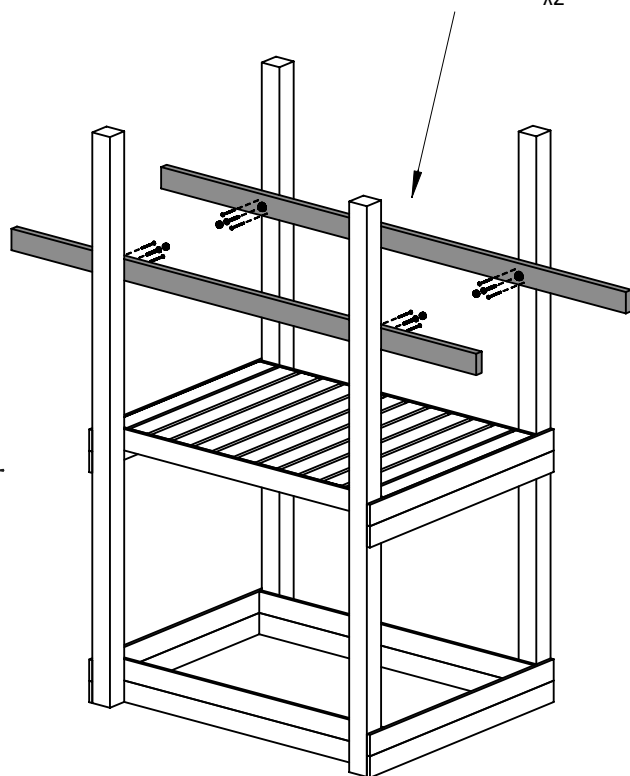

10 BUFFALO

Zgodnie z normą PN-EN 71 stosuj zalecenia producenta odnośnie odległości oraz metody mocowania poszczególnych elementów  
In compliance with the standard PN-EN 71, apply guidelines of the producer in relation to distances and methods of fastening individual elements

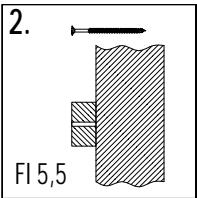
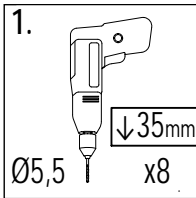

6a 3,5x9,0x98cm  
x2

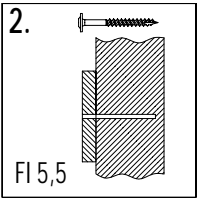
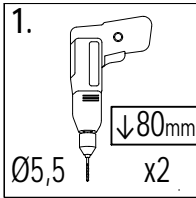
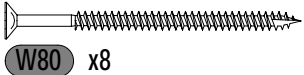
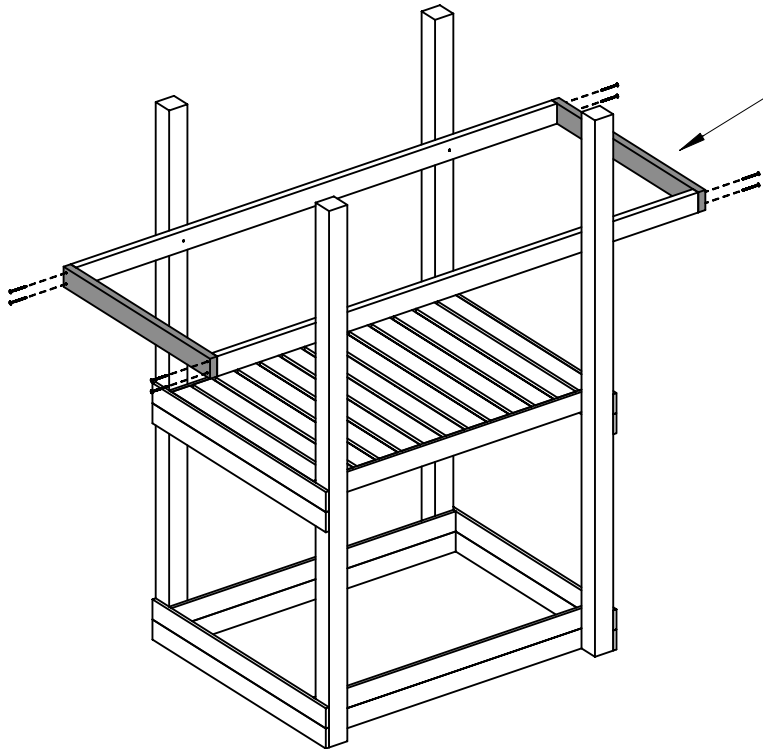

10a 3,2x5,8x140cm  
x1

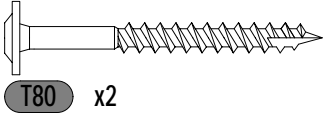
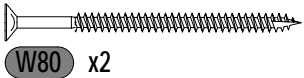
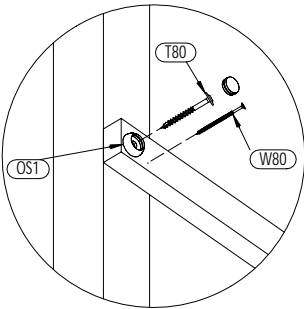
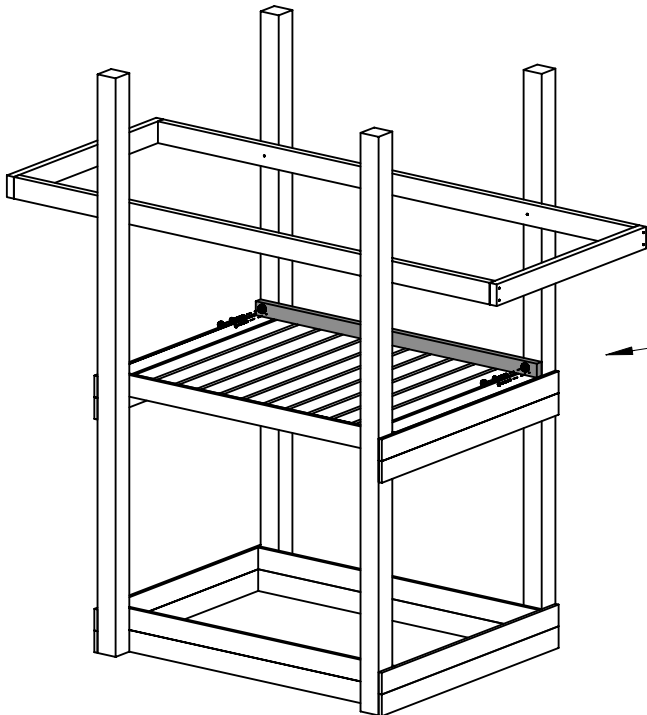

09

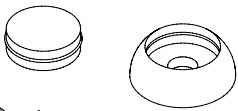
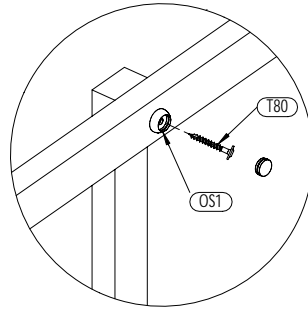
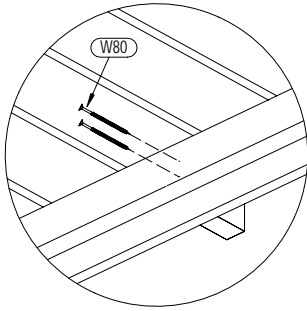
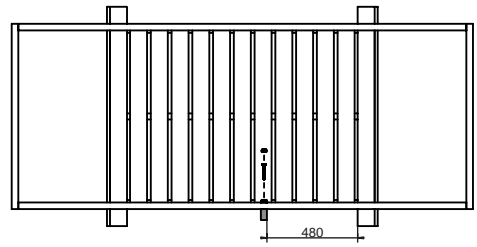
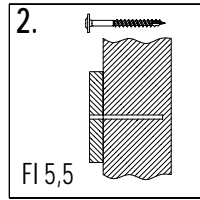
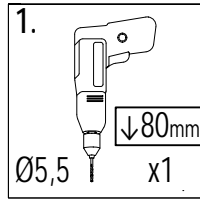

OS1 x1

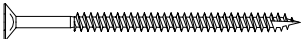

W80 x2

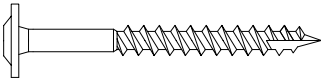

T80 x1

14 3,2x5,8x80cm x1

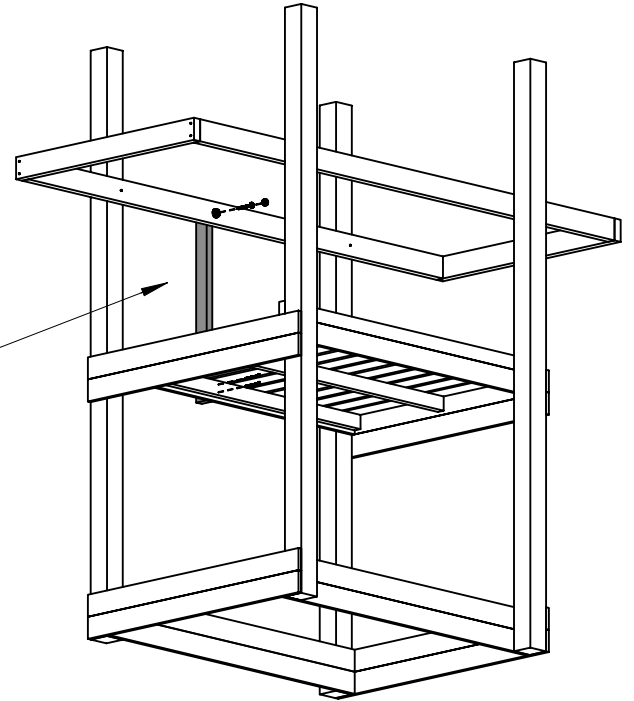

10

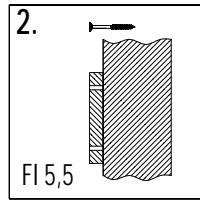
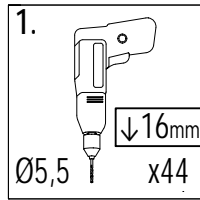

20 1,6x9,0x71,5cm x11

!!!min 13mm < a <!!!max 19mm

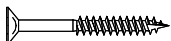
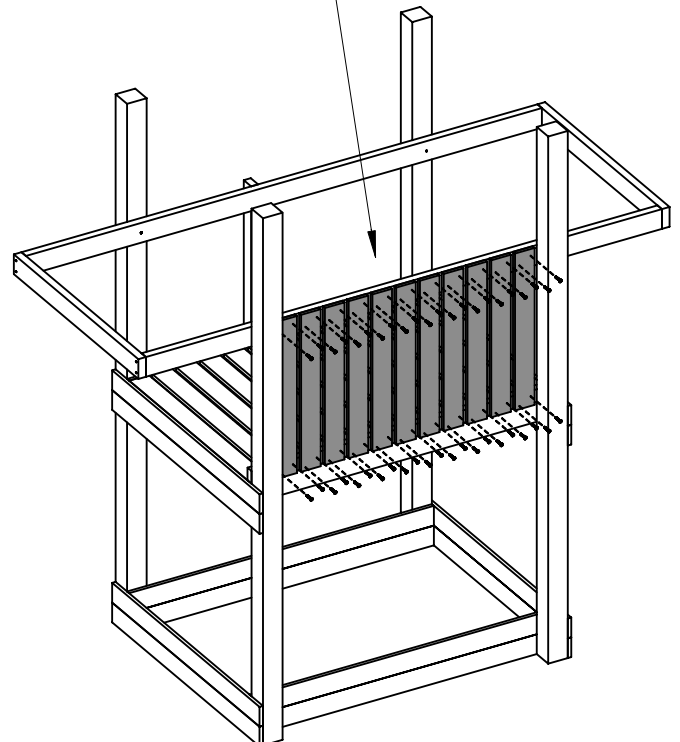
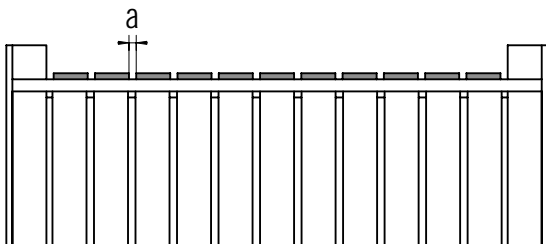

W40 x44

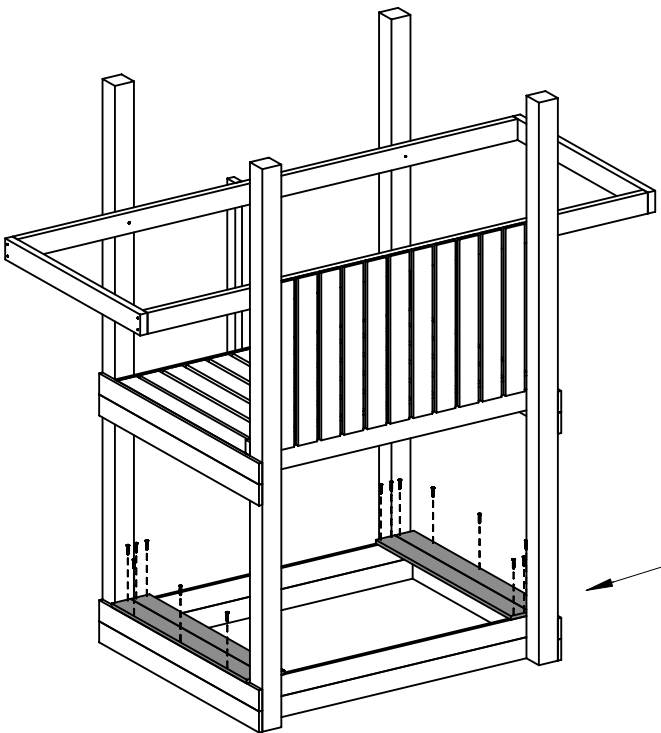
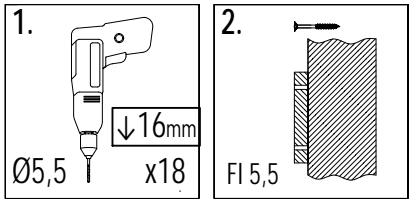

18 1,6x9,0x98cm  
x4

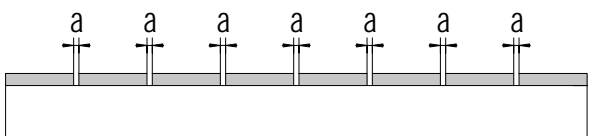
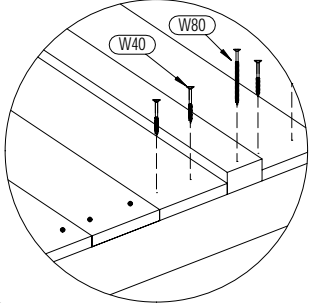
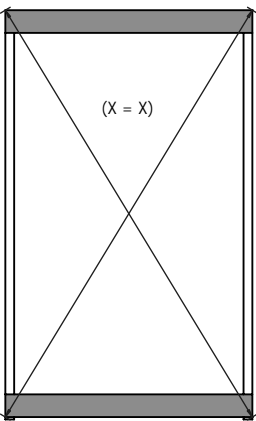
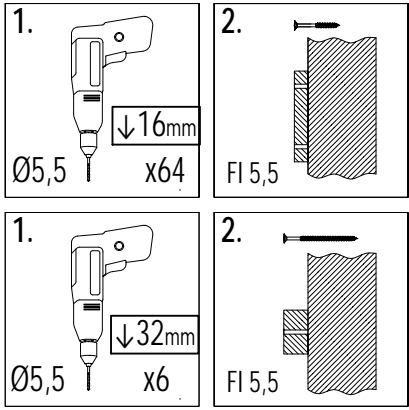
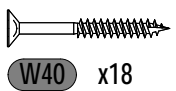
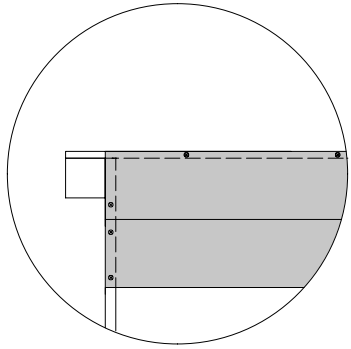

!!!min 2mm < a <!!!max 6mm

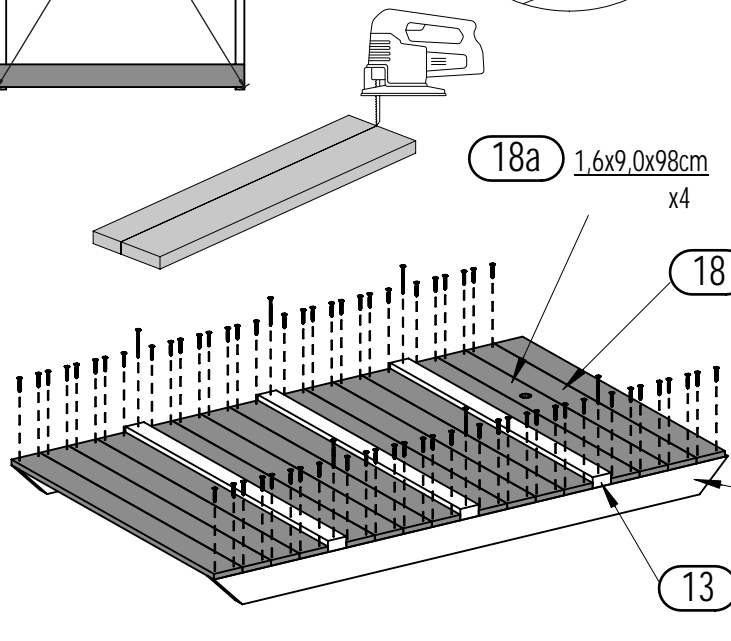

18a 1,6x9,0x98cm  
x4

18 1,6x9,0x98cm  
x15

3 3,5x9,0x162,5cm  
x2

13 3,2x5,8x98cm  
x3

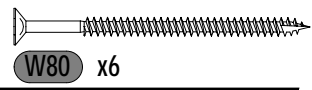
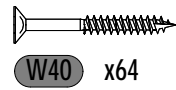
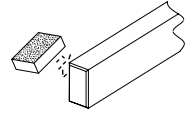

Zgodne z normą PN-EN 71 stosuj zalecenia producenta odnośnie odległości oraz metody mocowania poszczególnych elementów  
In compliance with the standard PN-EN 71, apply guidelines of the producer in relation to distances and methods of fastening individual elements

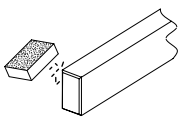
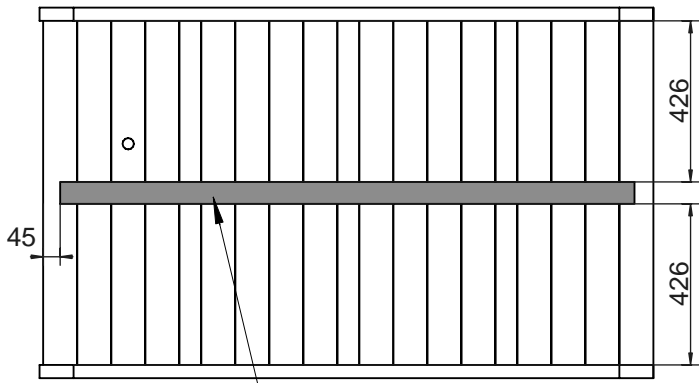

9 3,2x5,8x152cm  
x1

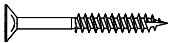
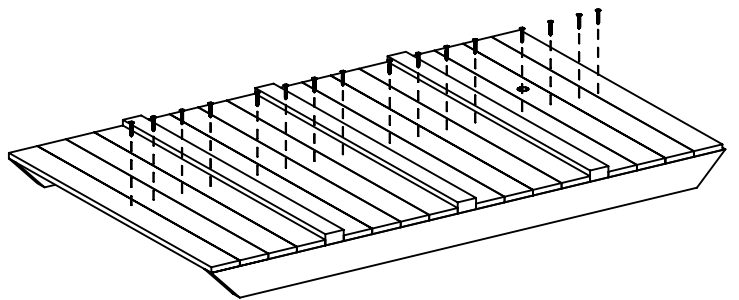

W40 x16

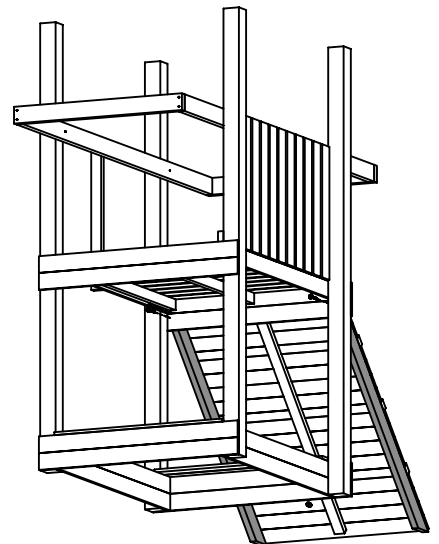
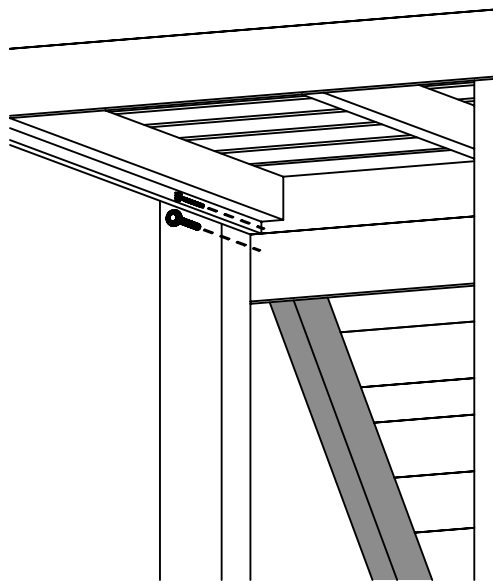
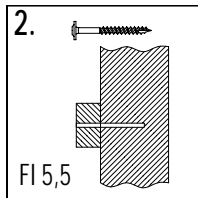
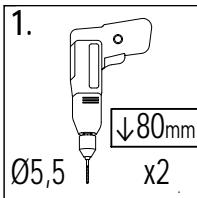

W80 x2

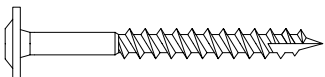

T80 x2

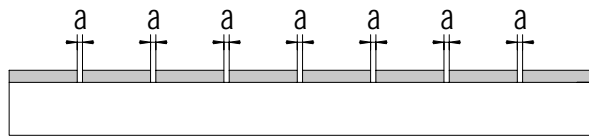
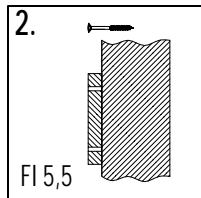
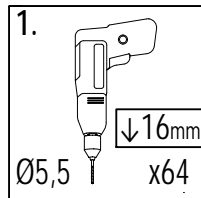
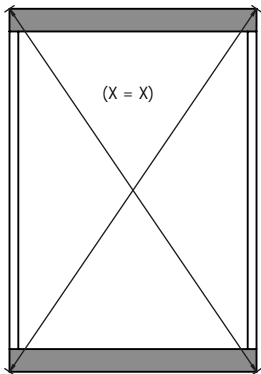

!!!min 2mm < a < !!!max 6mm

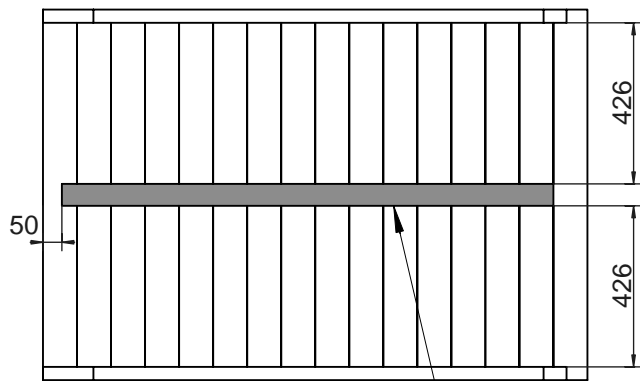
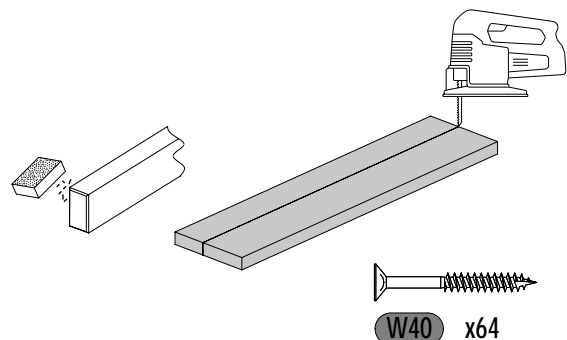
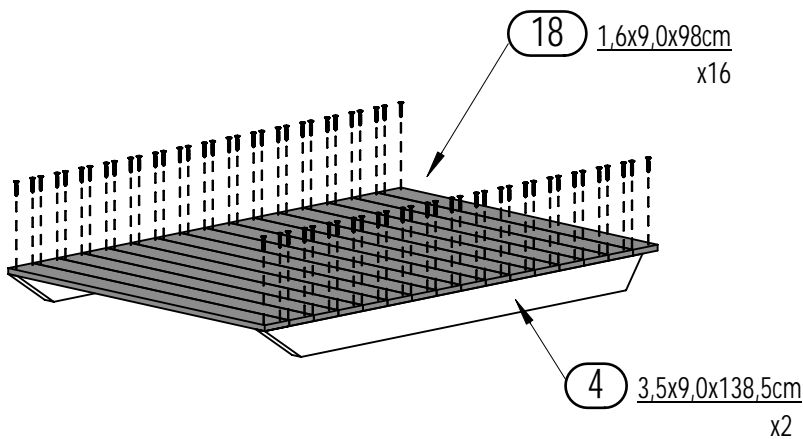
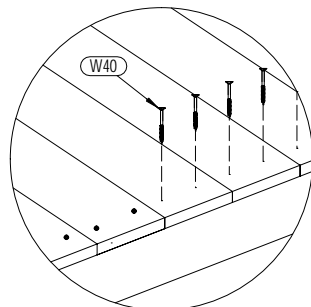

11 3,2x5,8x130cm x1

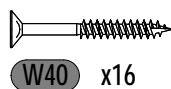
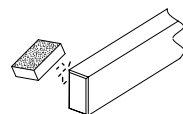
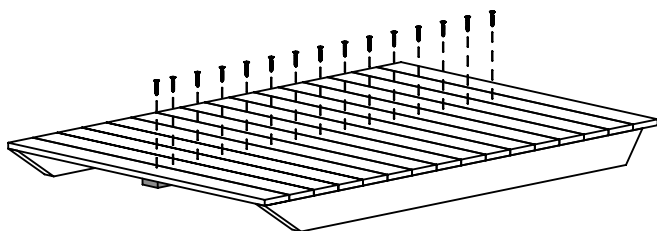

17

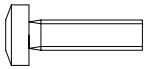
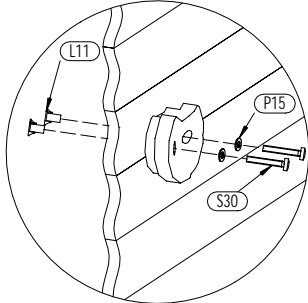
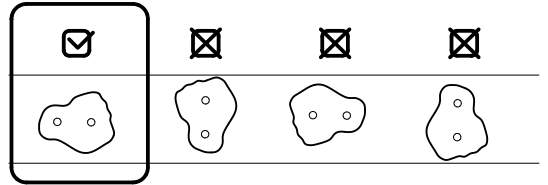
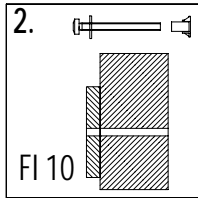
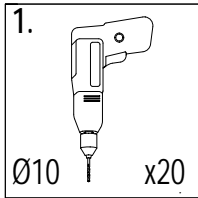

S30 x20



P15 x20



L11 x20

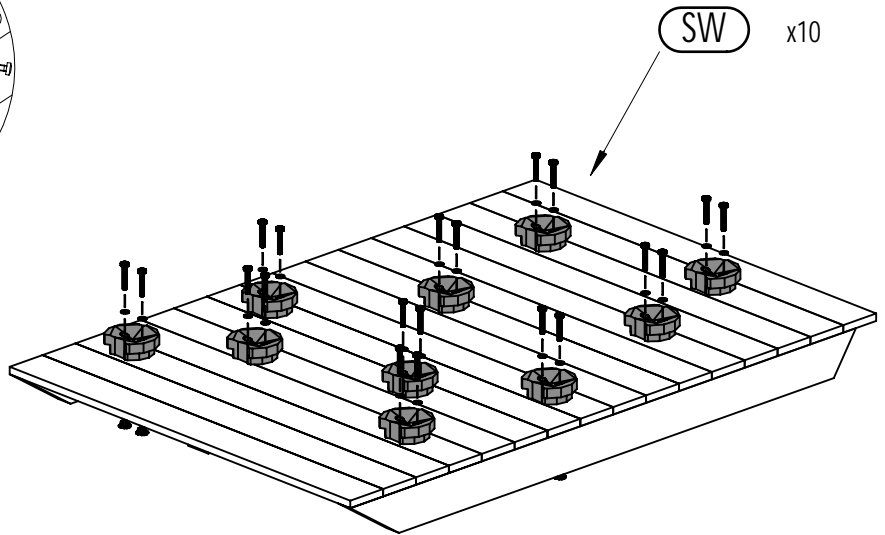

18

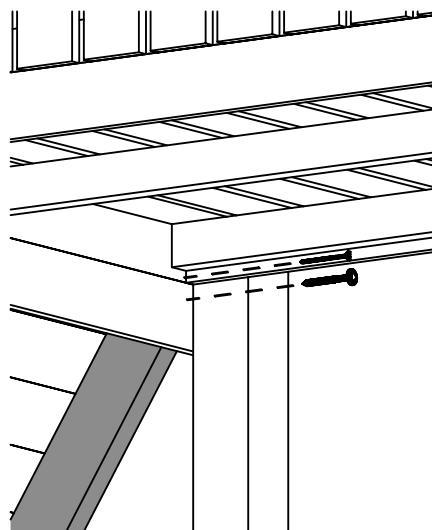
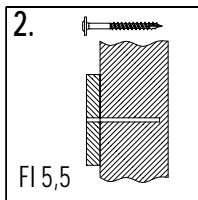
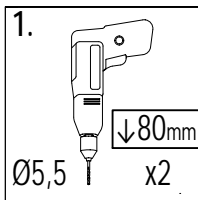

W80 x2

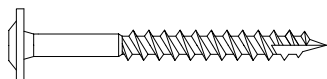

T80 x2

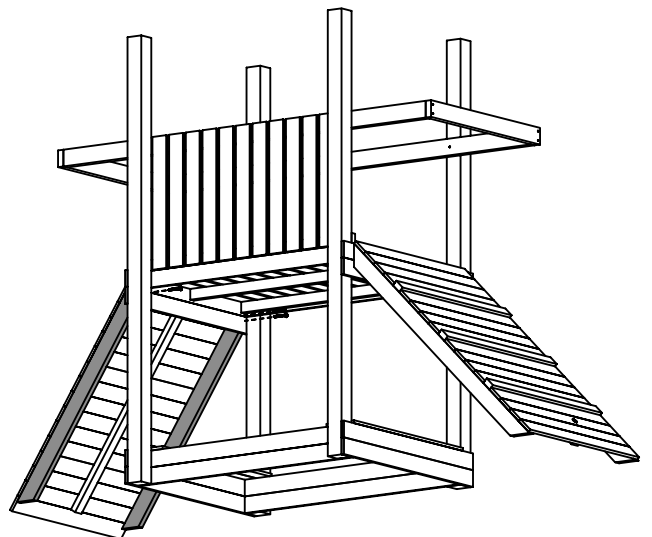

16 BUFFALO

Zgodnie z normą PN-EN 71 stosuj zalecenia producenta odnośnie odległości oraz metody mocowania poszczególnych elementów  
 In compliance with the standard PN-EN 71, apply guidelines of the producer in relation to distances and methods of fastening individual elements



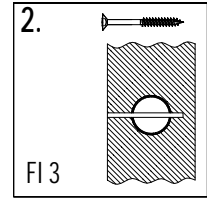
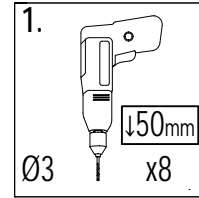
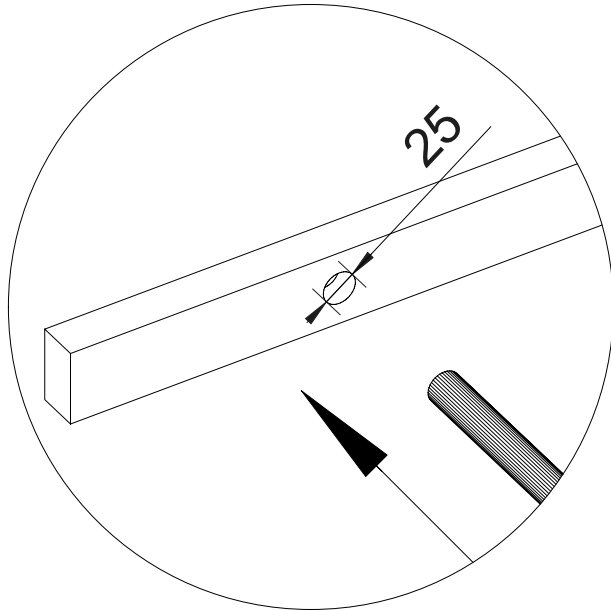
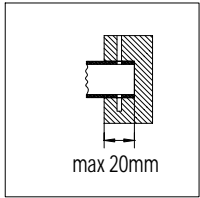

19

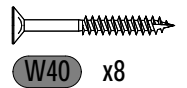
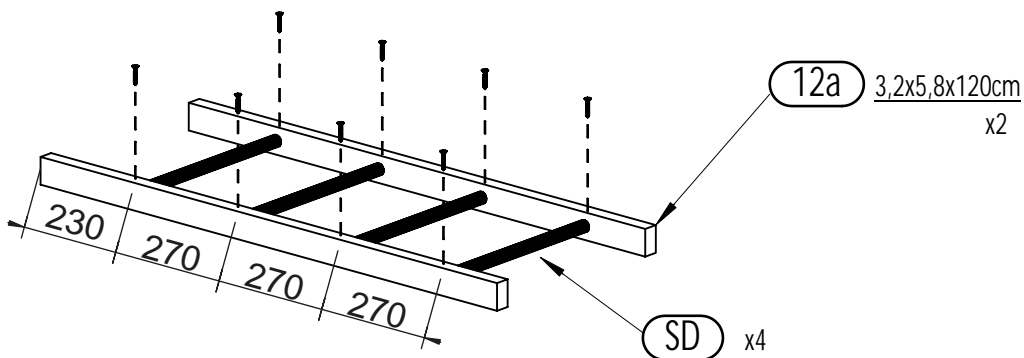

20

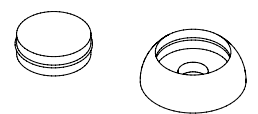
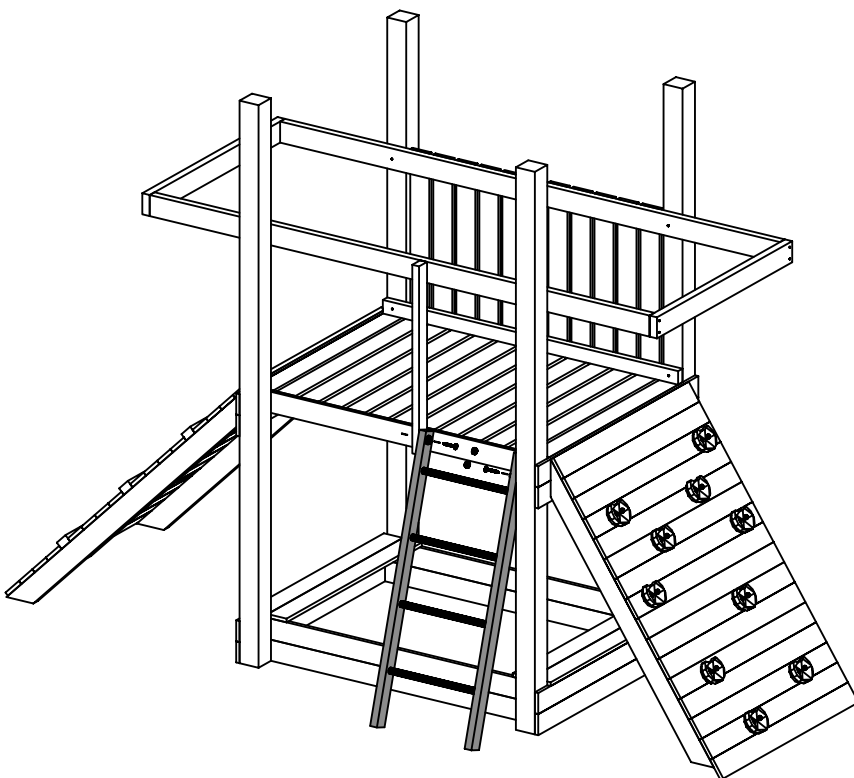

OS1 x2

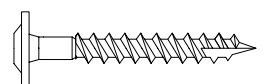

T60 x2

21

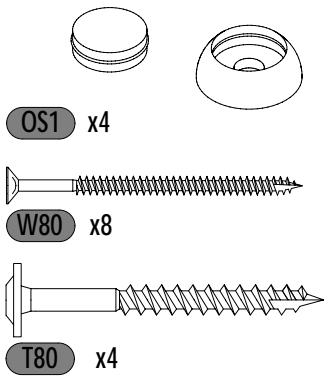
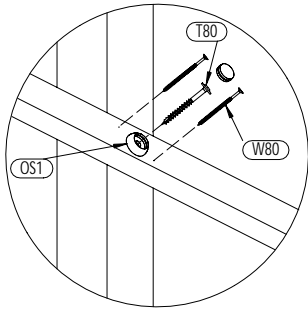
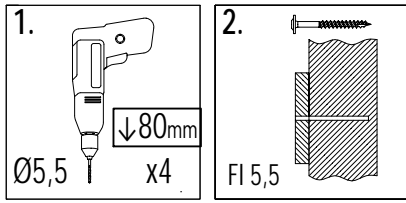

5a 3,5x9,0x116cm x2

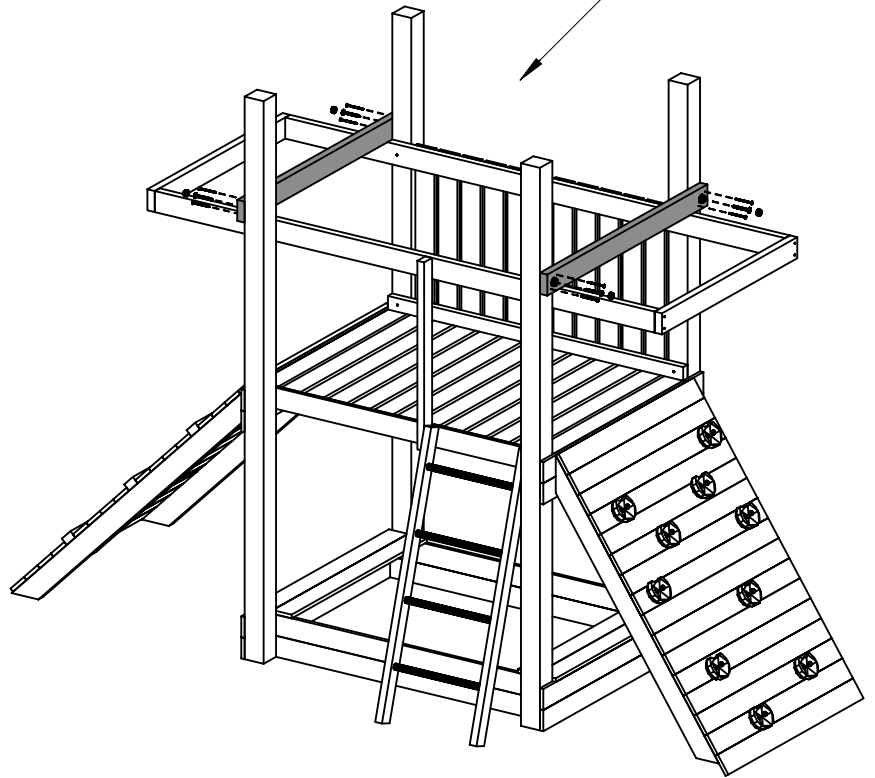

22

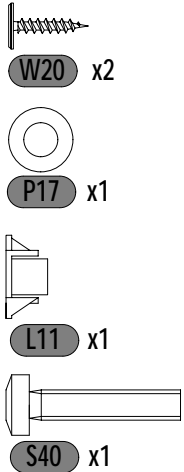
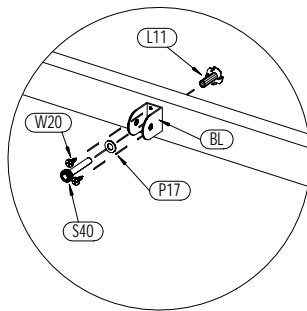
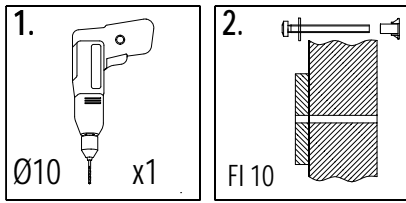

BL x1

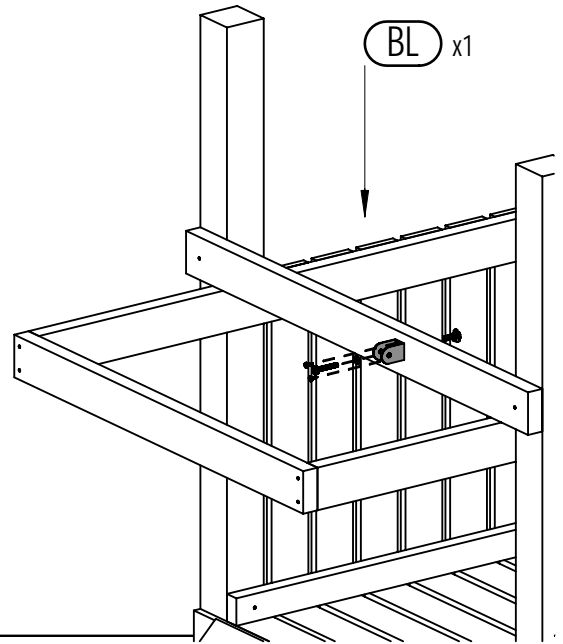

17 1,6x9,0x105cm  
x4

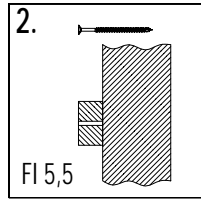
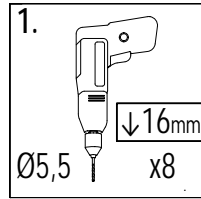
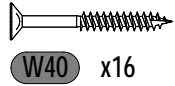
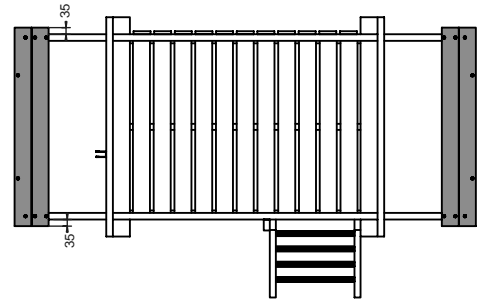
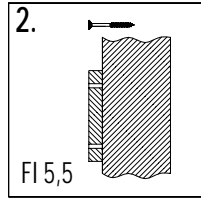
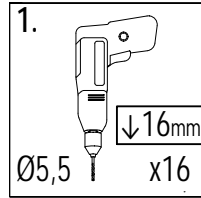
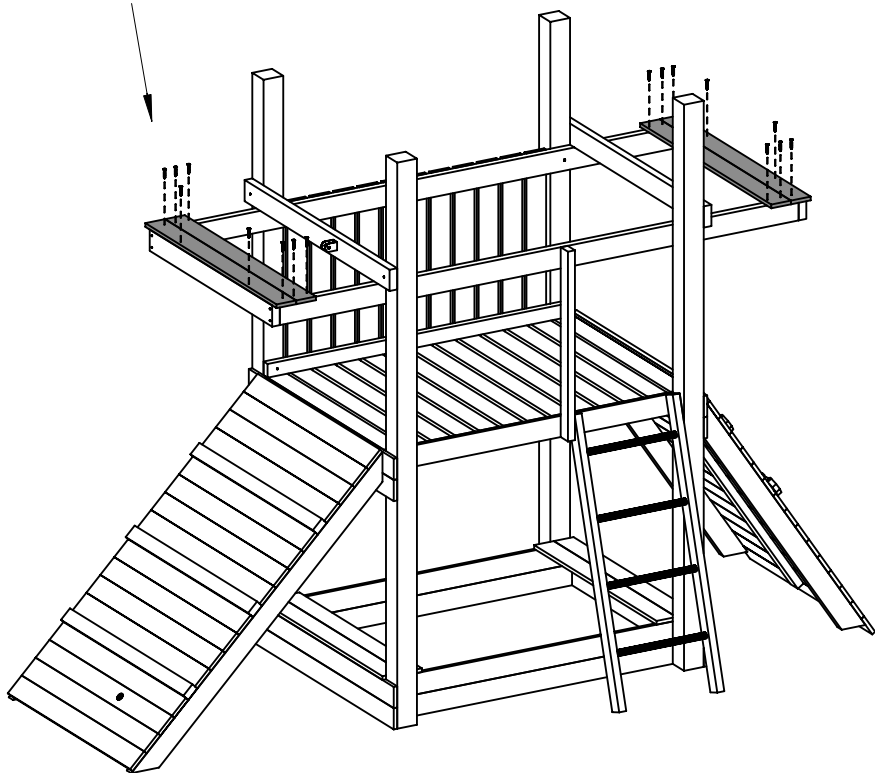

8 3,5x9,0x72cm  
x4

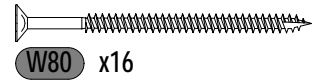
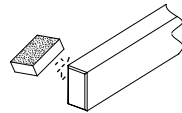
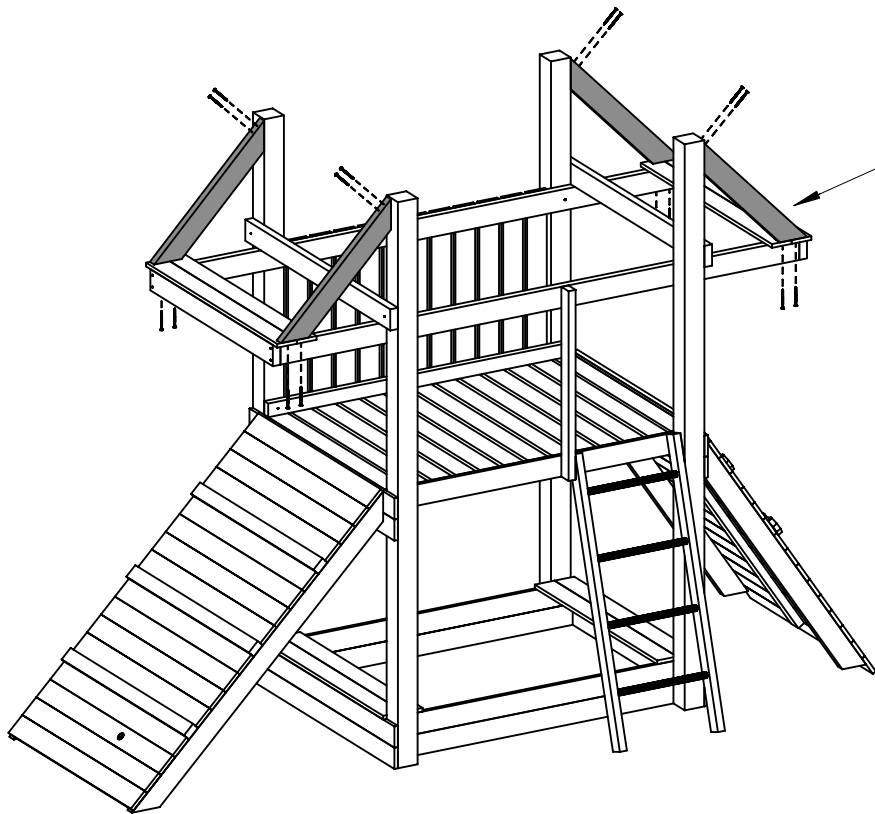

Zgodne z normą PN-EN 71 stosuj zalecenia producenta odnośnie odległości oraz metody mocowania poszczególnych elementów  
In compliance with the standard PN-EN 71, apply guidelines of the producer in relation to distances and methods of fastening individual elements

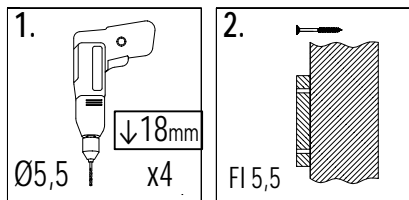

!!! x2

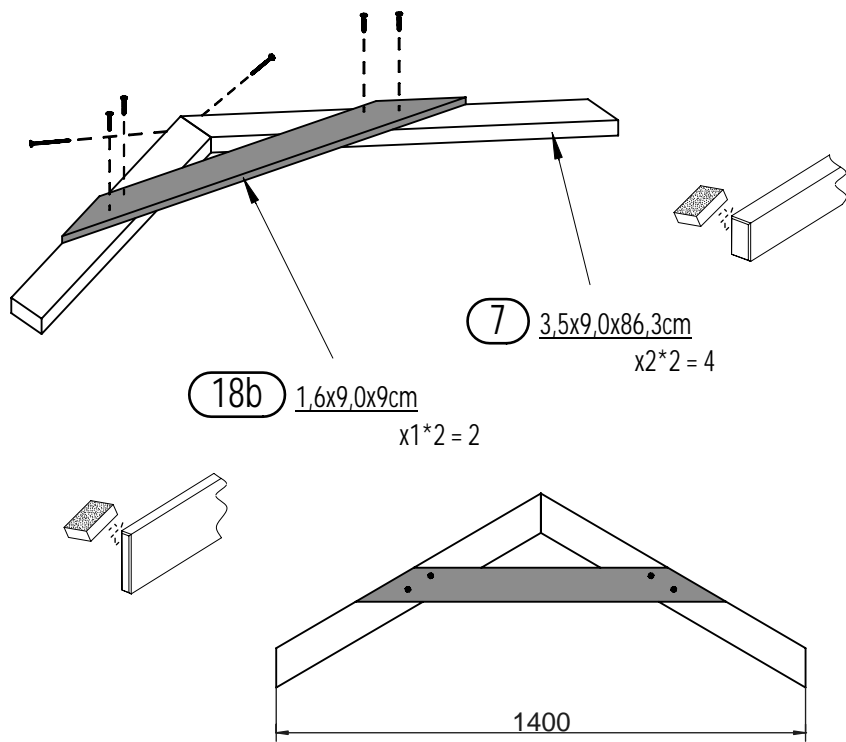

W40 x4\*2 = 8

W80 x2\*2 = 4

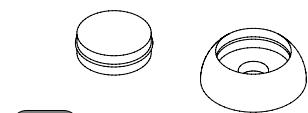
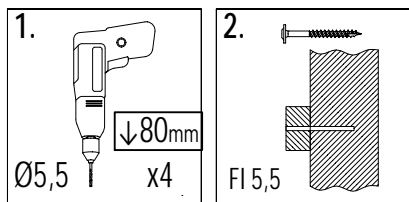

W80 x4

T80 x4

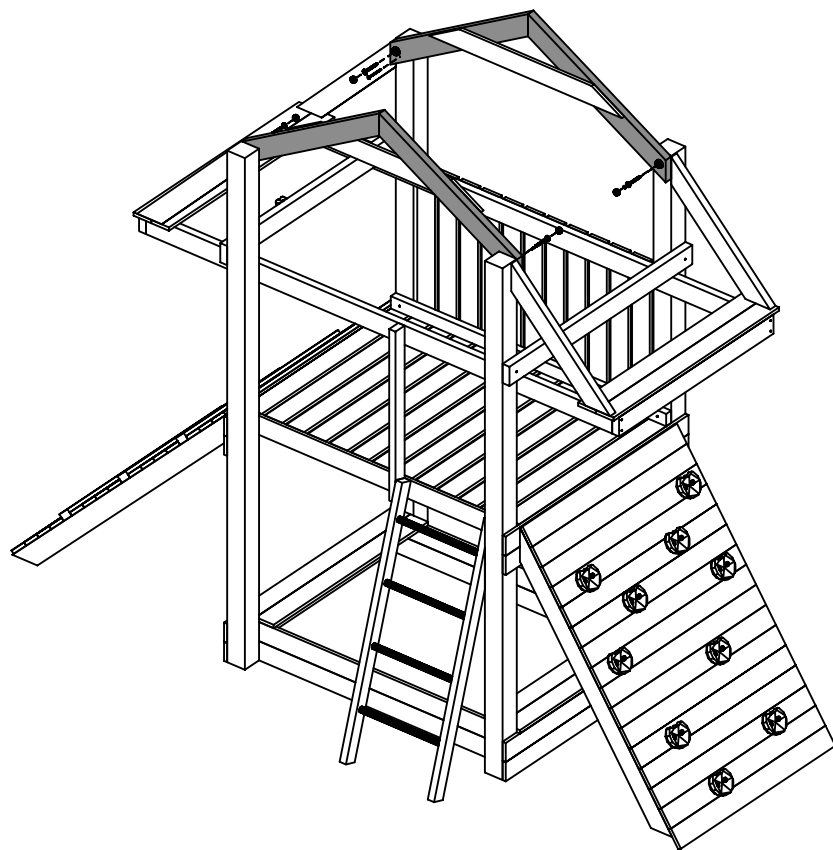

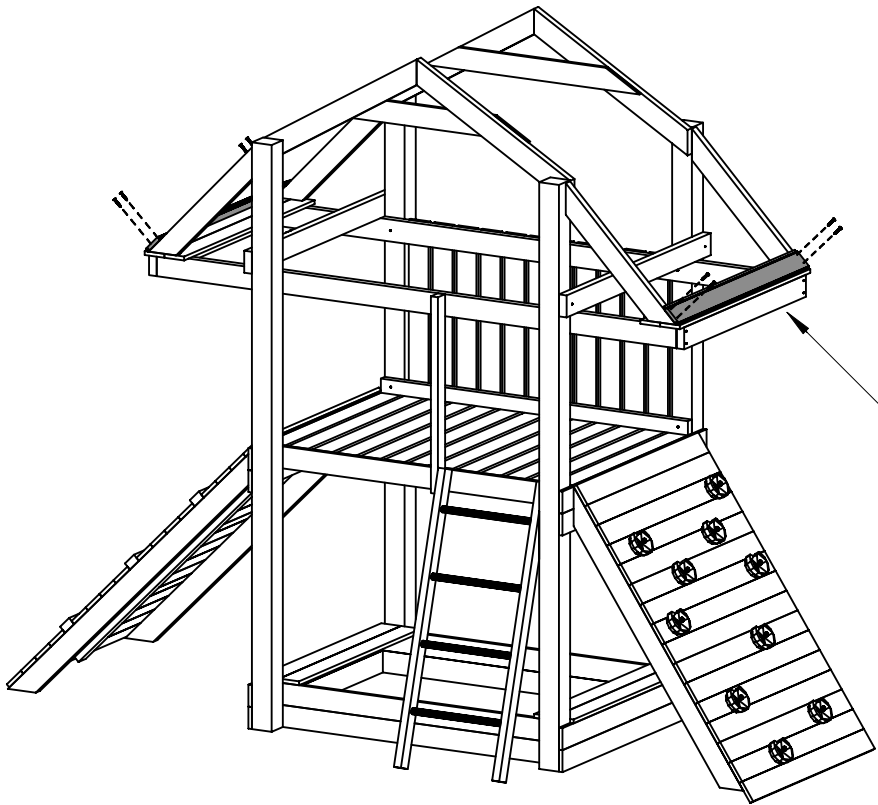
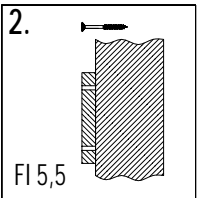
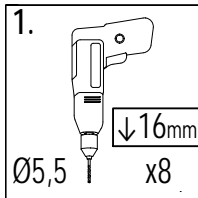

17a 1,6x9,0x105cm  
x2

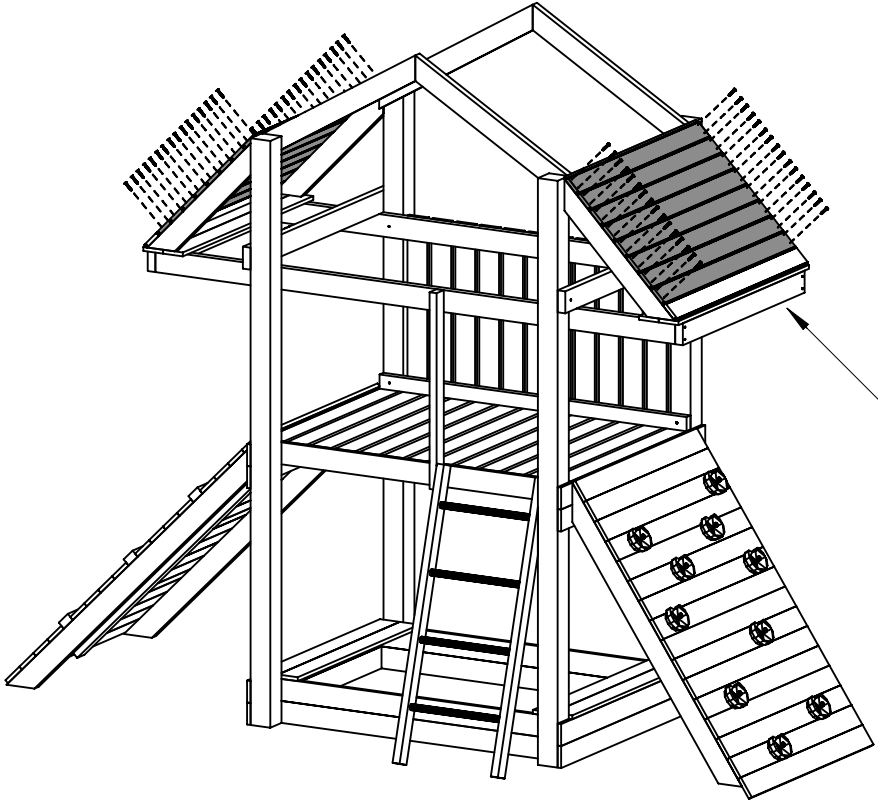
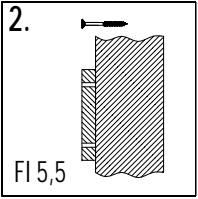
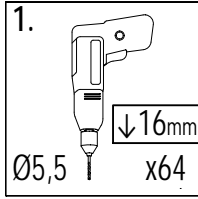
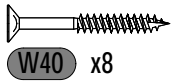

17a 1,6x9,0x105cm  
x16

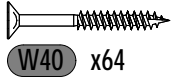

Zgodne z normą PN-EN 71 stosuj zalecenia producenta odnośnie odległości oraz metody mocowania poszczególnych elementów  
 In compliance with the standard PN-EN 71, apply guidelines of the producer in relation to distances and methods of fastening individual elements

29

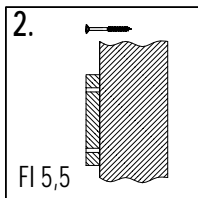
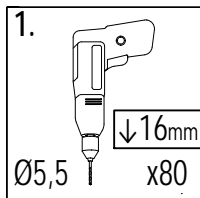

17a 1,6x9,0x105cm x20

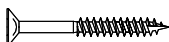
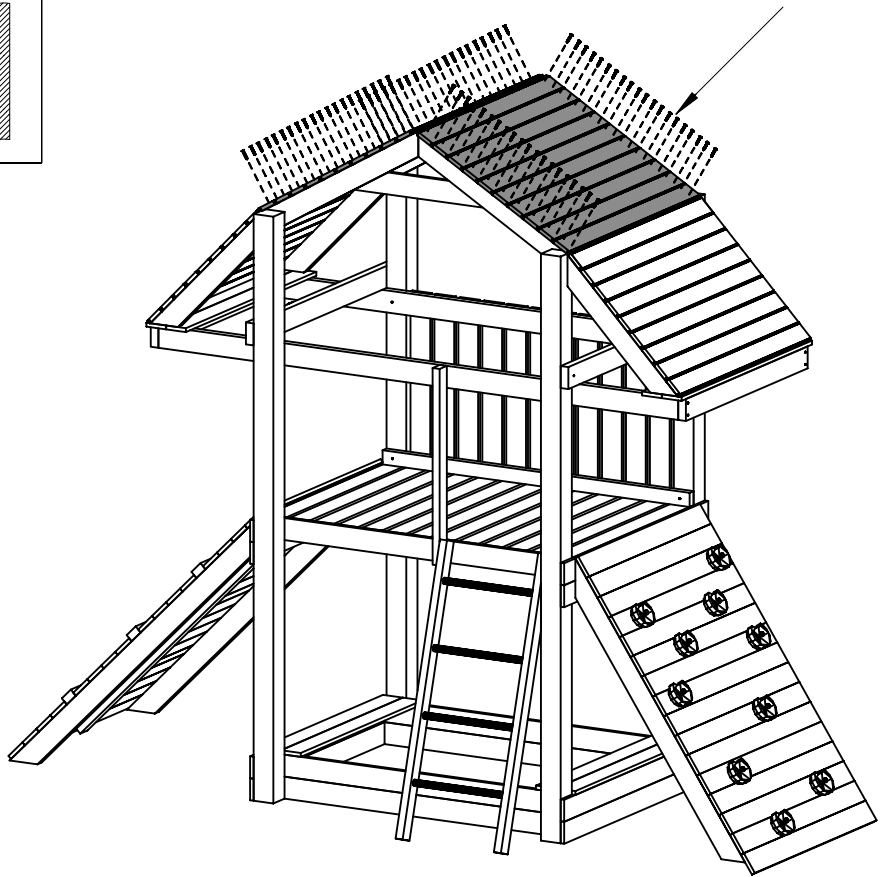

W40 x80

30

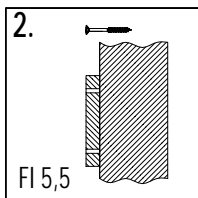
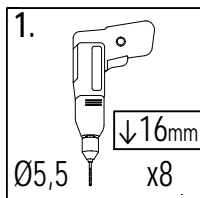

17 1,6x9,0x105cm x2

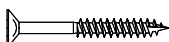
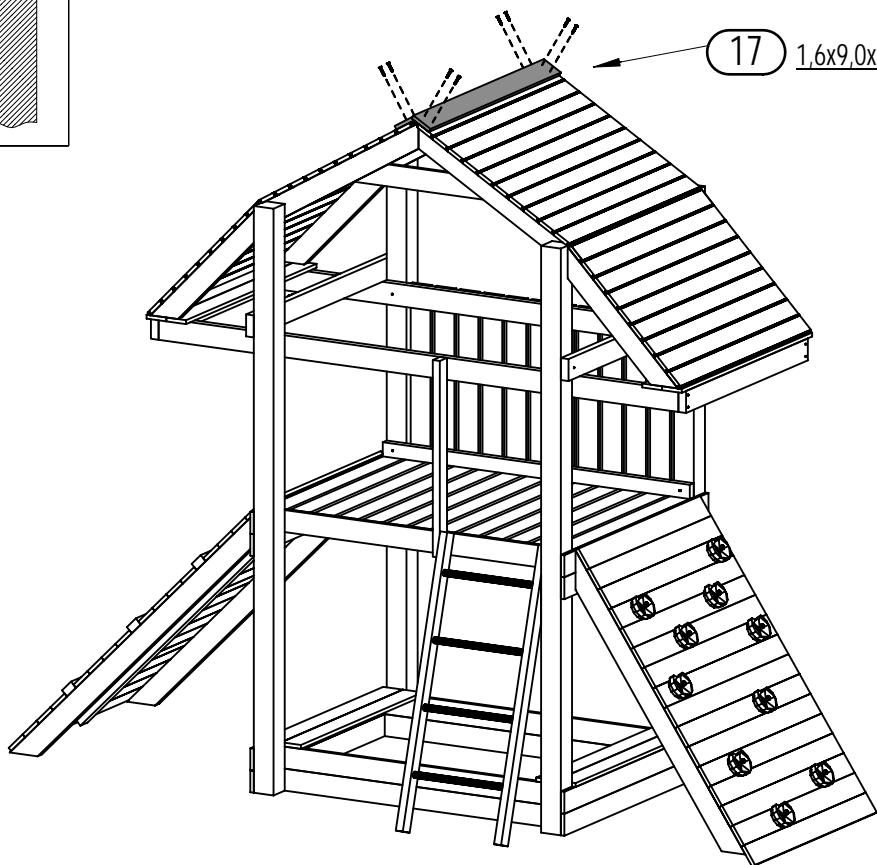

W40 x8

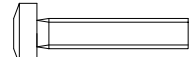
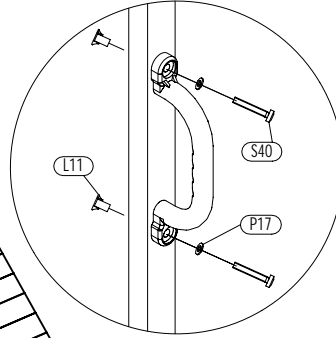
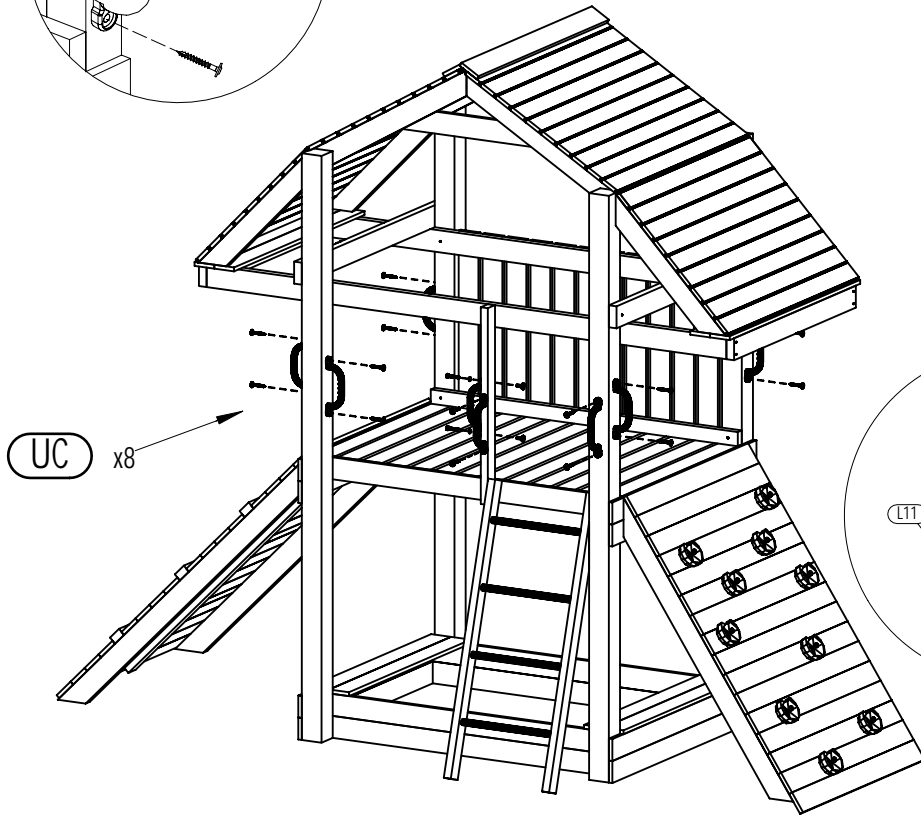
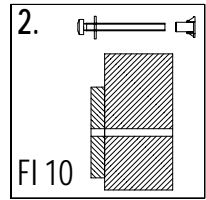
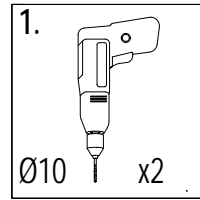
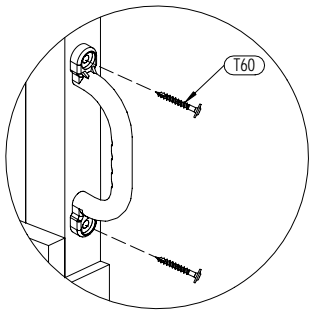

S40 x2



P17 x2



L11 x2



T60 x14

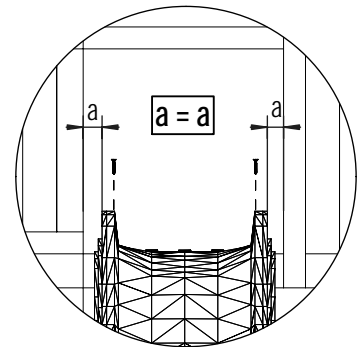
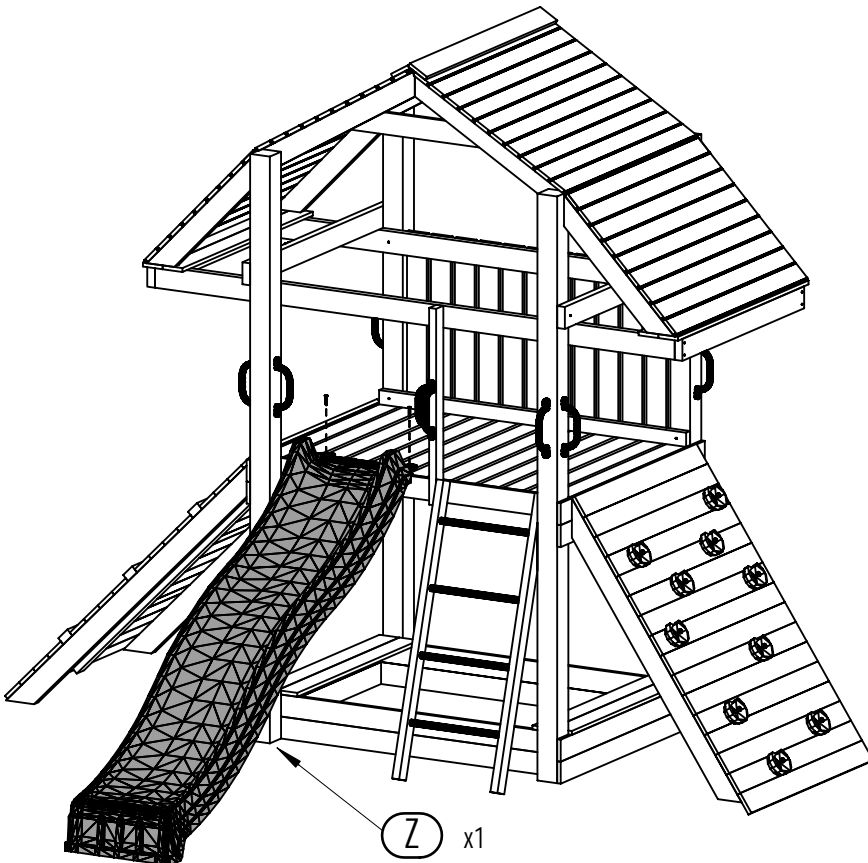

W30 x2

Zgodnie z normą PN-EN 71 stosuj zalecenia producenta odnośnie odległości oraz metody mocowania poszczególnych elementów  
 In compliance with the standard PN-EN 71, apply guidelines of the producer in relation to distances and methods of fastening individual elements

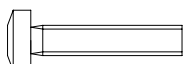
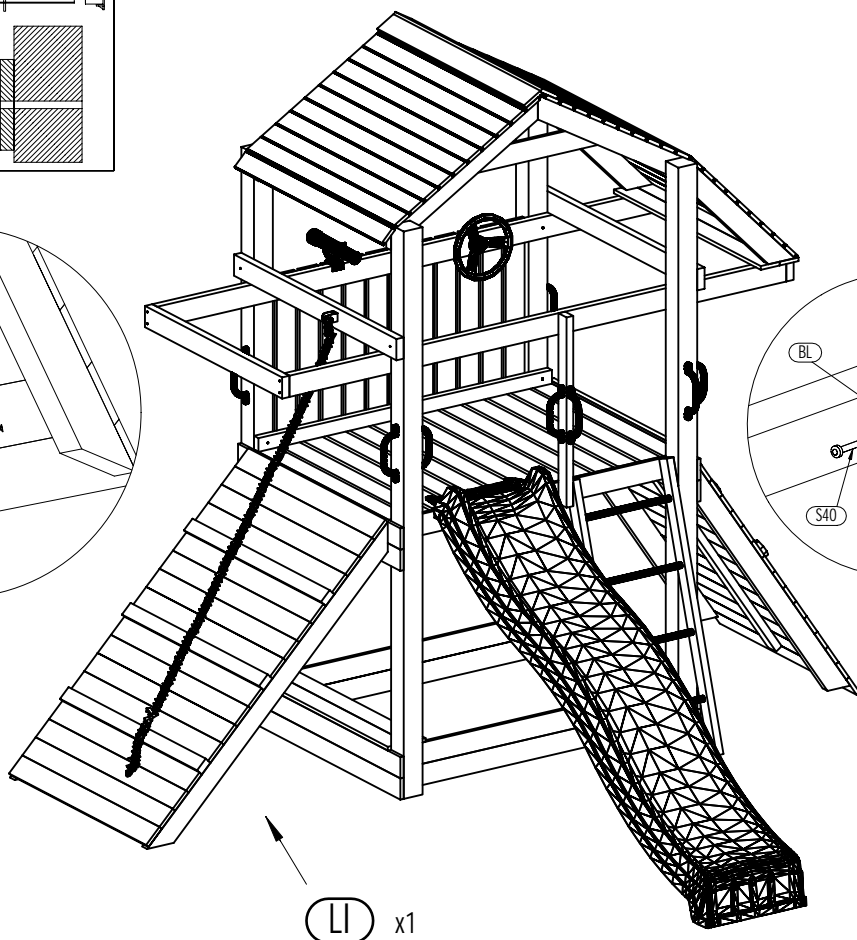
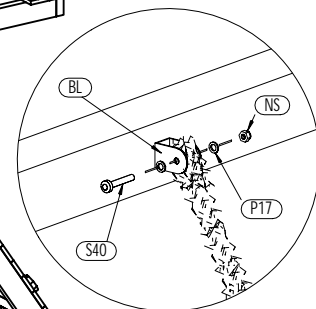
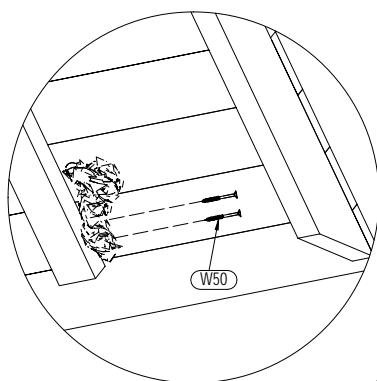
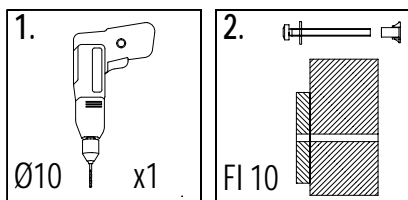
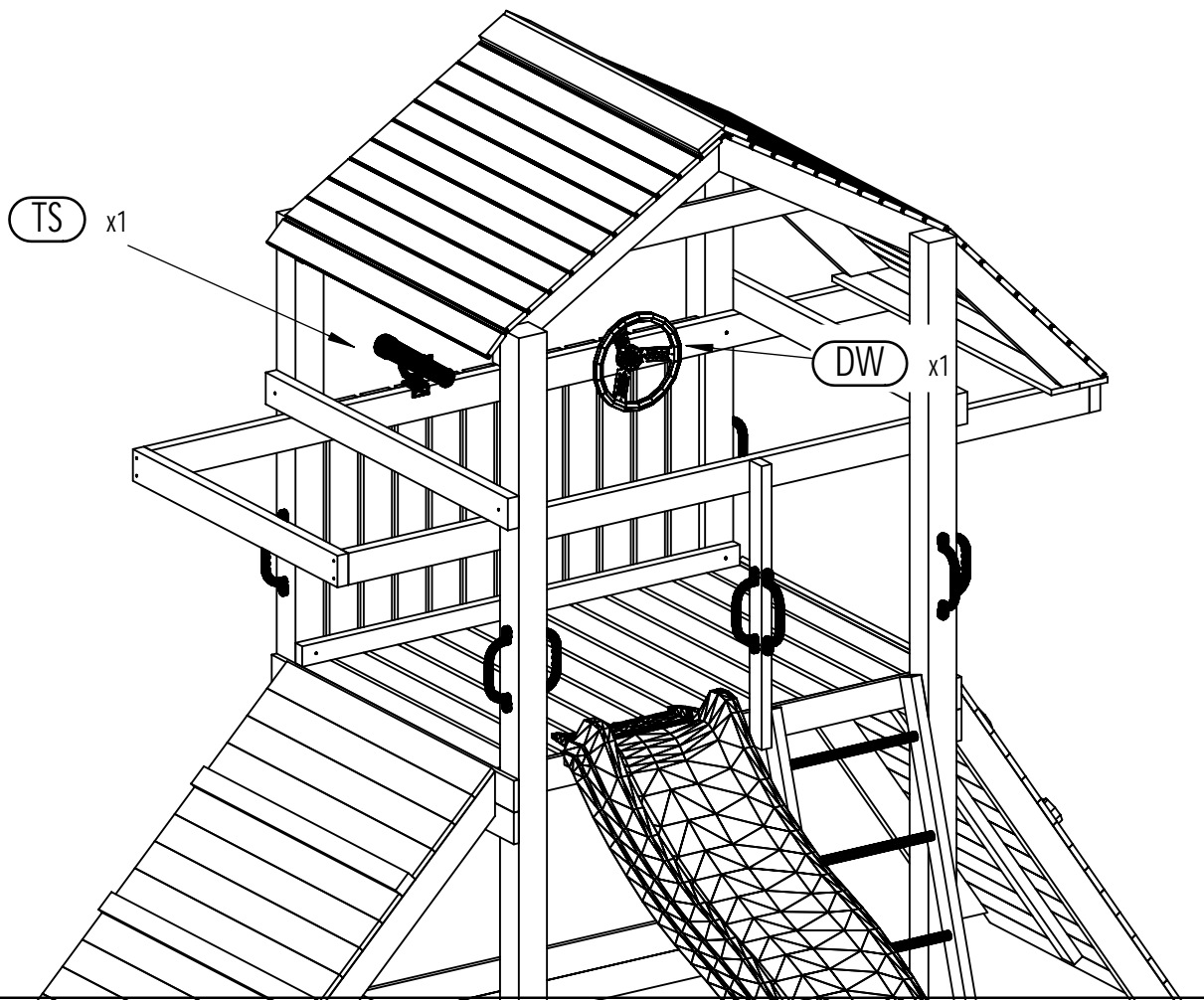

S40 x1



P17 x2



NS x1

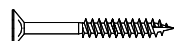

W40 x2

LI x1



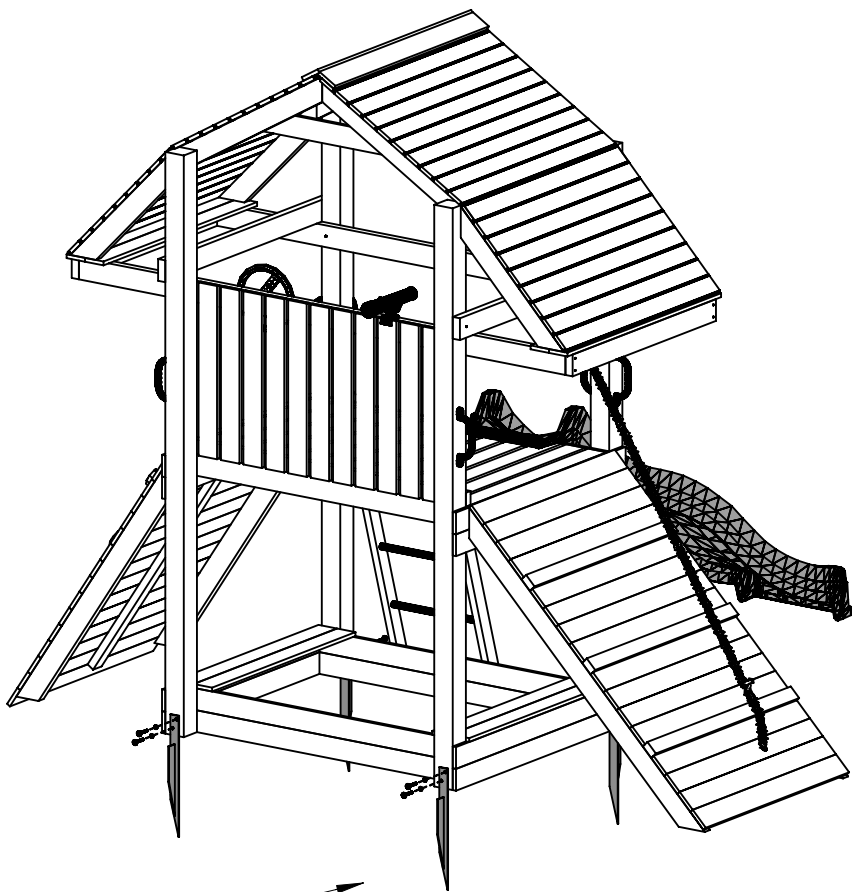

MG x4

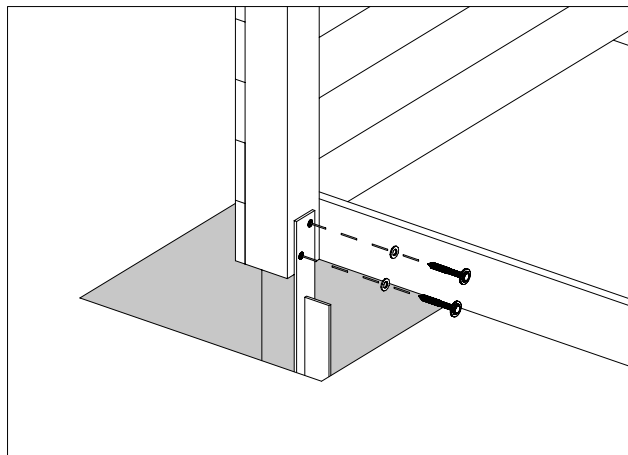

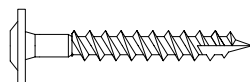

  
P17 x8

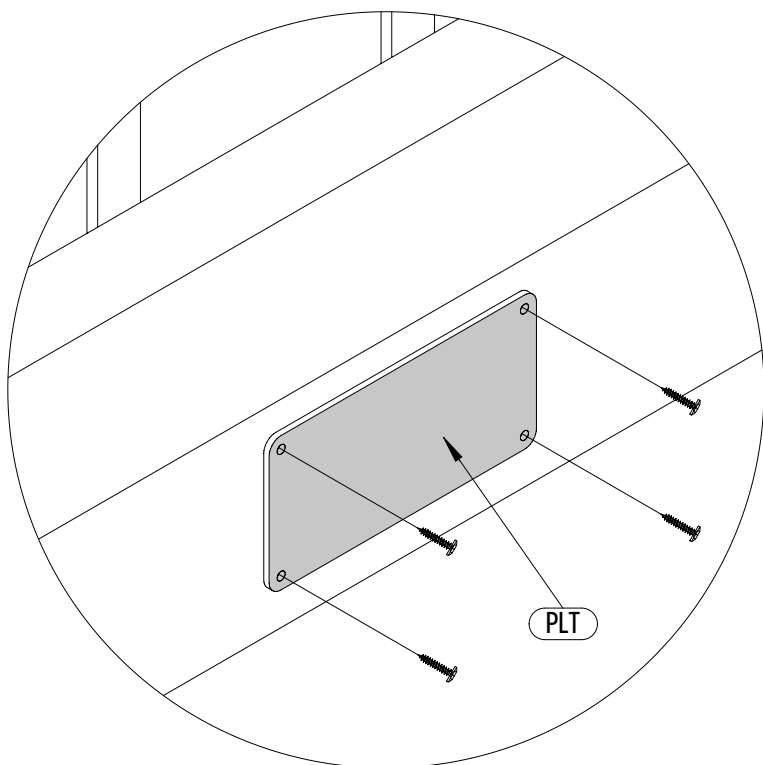
  
T60 x8

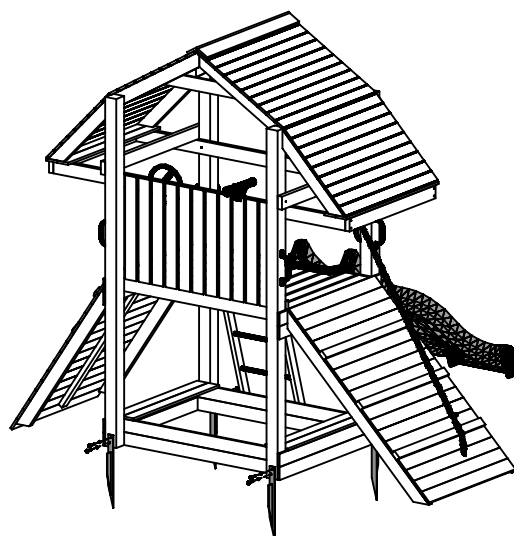

PLT



  
W20 x4

# AUSBAU MOVE RED

(305 x 253 x h240cm)

003\_04400\_08032019

## MONTAGEANLEITUNG

Garantiezeit - 2 Jahre ab Kaufdatum

Période de garantie - 2 ans à compter de l'achat



# AGRANDISSEMENTS MOVE RED

(305 x 253 x h240cm)

003\_04400\_08032019

## GUIDE D'INSTALLATION

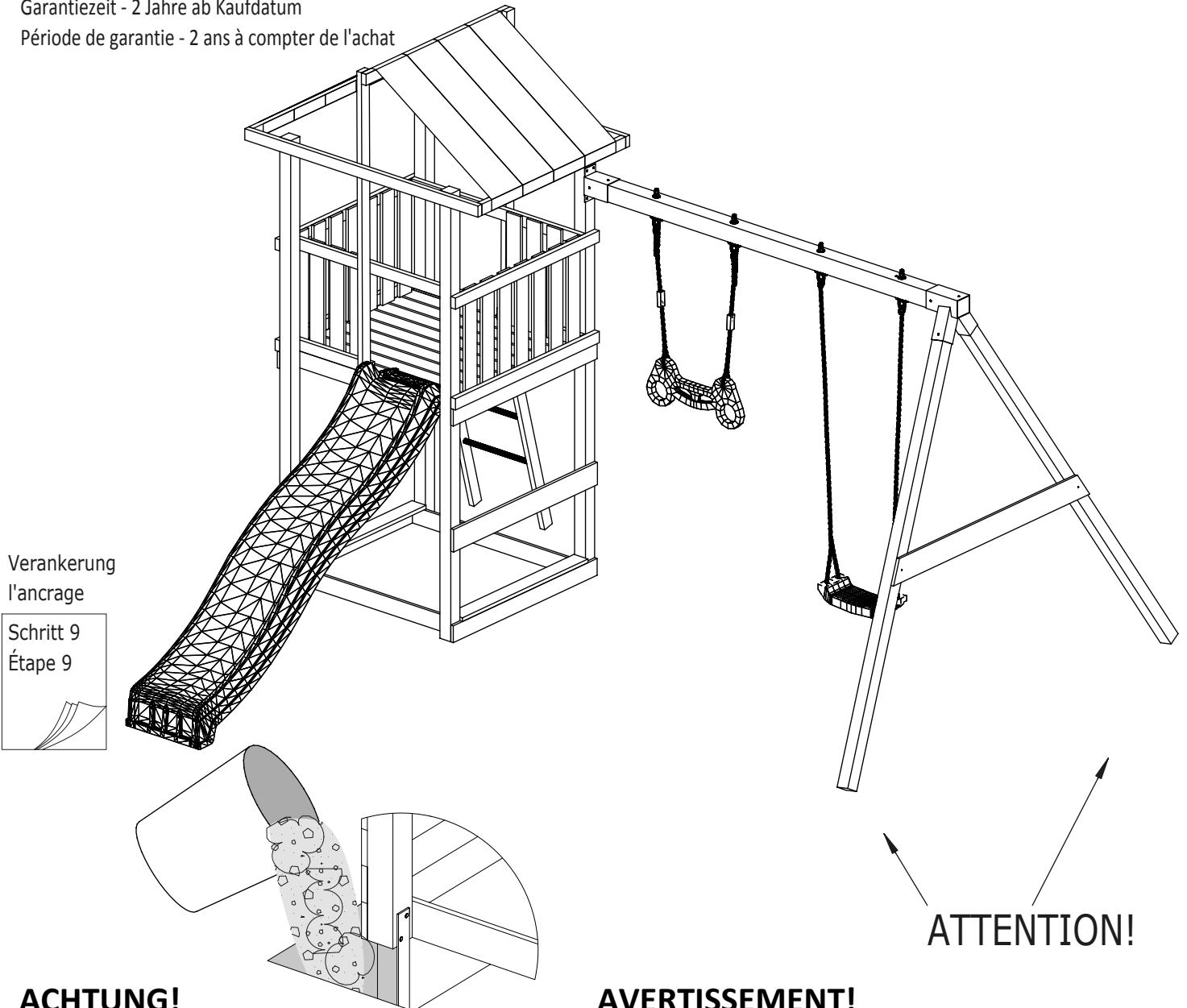

### ACHTUNG!

Nur für den privaten, häuslichen Bereich.  
Ausschließlich für die Verwendung im Freien.  
Nicht geeignet für Kinder unter 3 Jahren.  
Stolper- und / oder Sturzgefahr  
Höchstgewicht pro Einzelkind beträgt 50 kg  
Der Aufenthalt auf diesem Spielturm ist max. : 2.  
Kindern gleichzeitig erlaubt.

### AVERTISSEMENT!

Aire exclusivement destinée à un usage privé.  
Aire exclusivement destinée à un usage en extérieur.  
Prévue pour les enfants de plus de 3 ans.  
Danger de chute ou de choc.  
Poids maximal d'un utilisateur : 50 kg.  
Nombre maximal d'utilisateurs présents en même temps sur la même aire de jeux : 2.



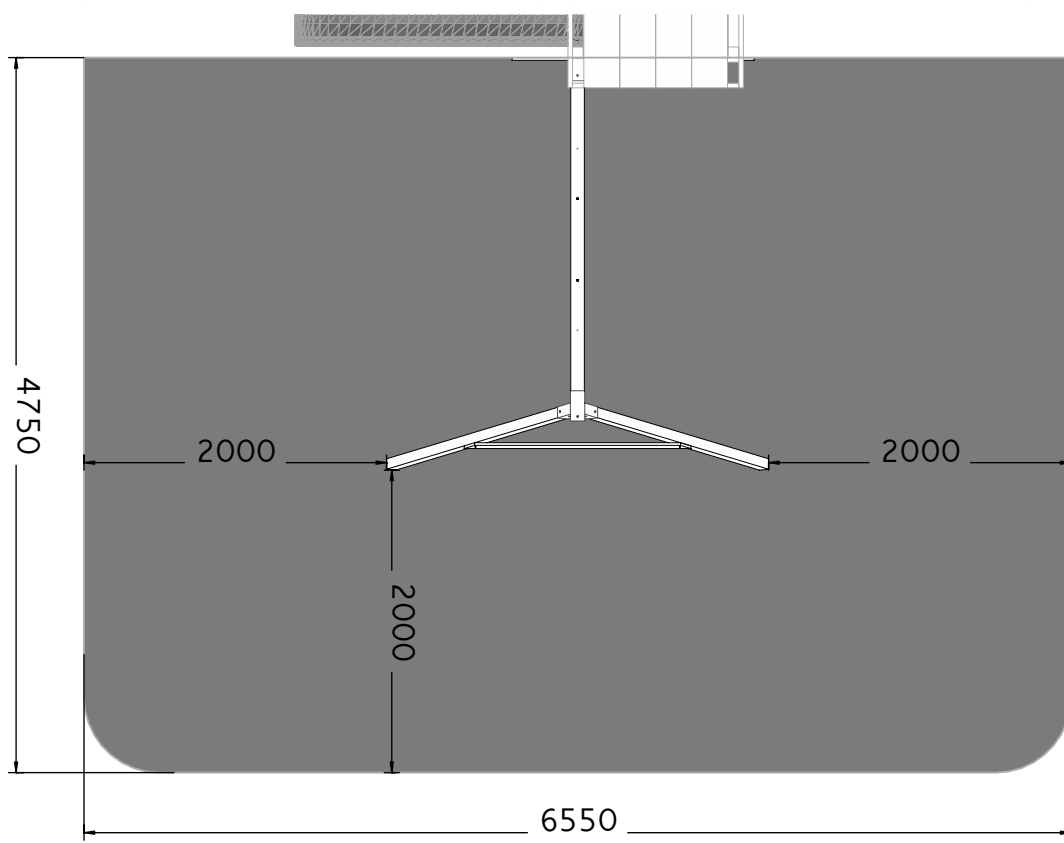

**W80** x8

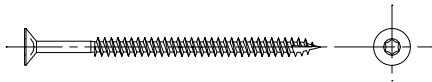

**T80** x4

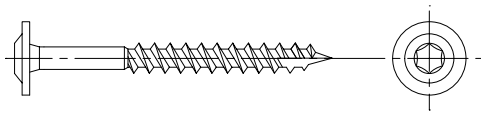

**T60** x17

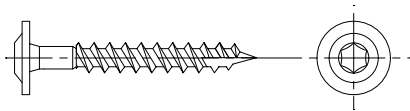

**P17** x17

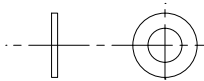

**OS1** x4

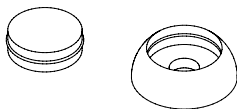

**W20** x4

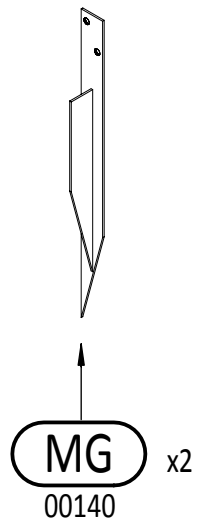
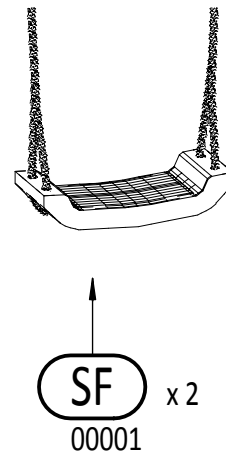
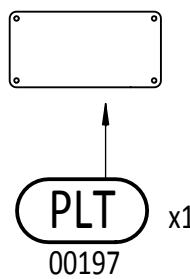
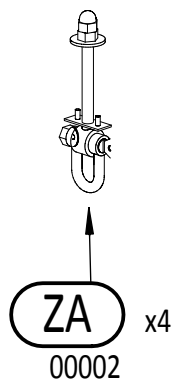
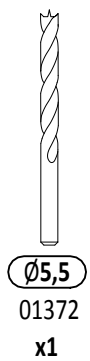
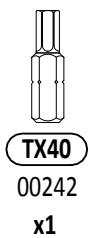
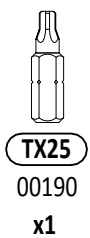
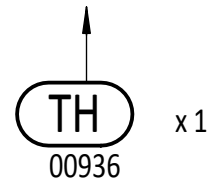
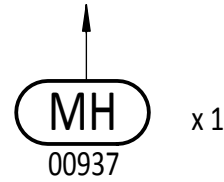
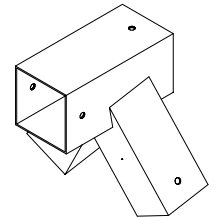
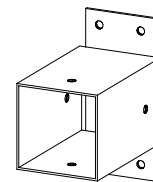

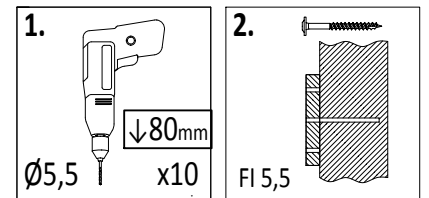
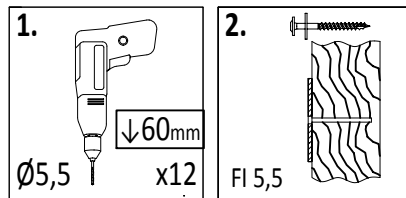
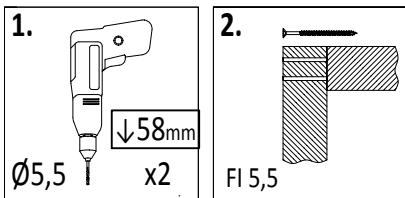
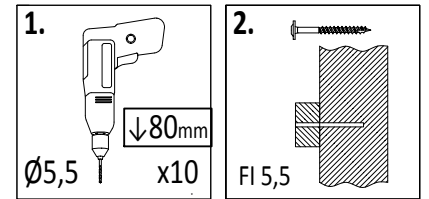
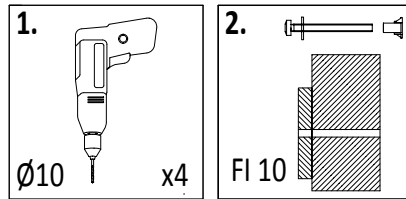
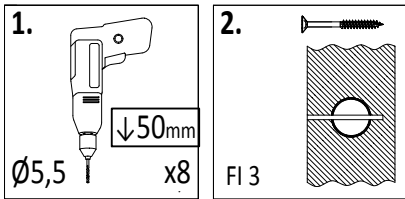
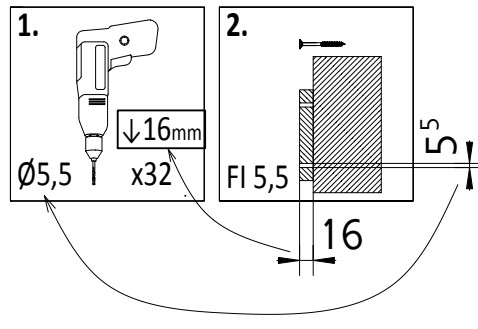
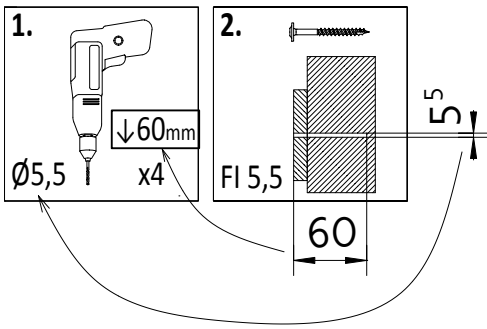
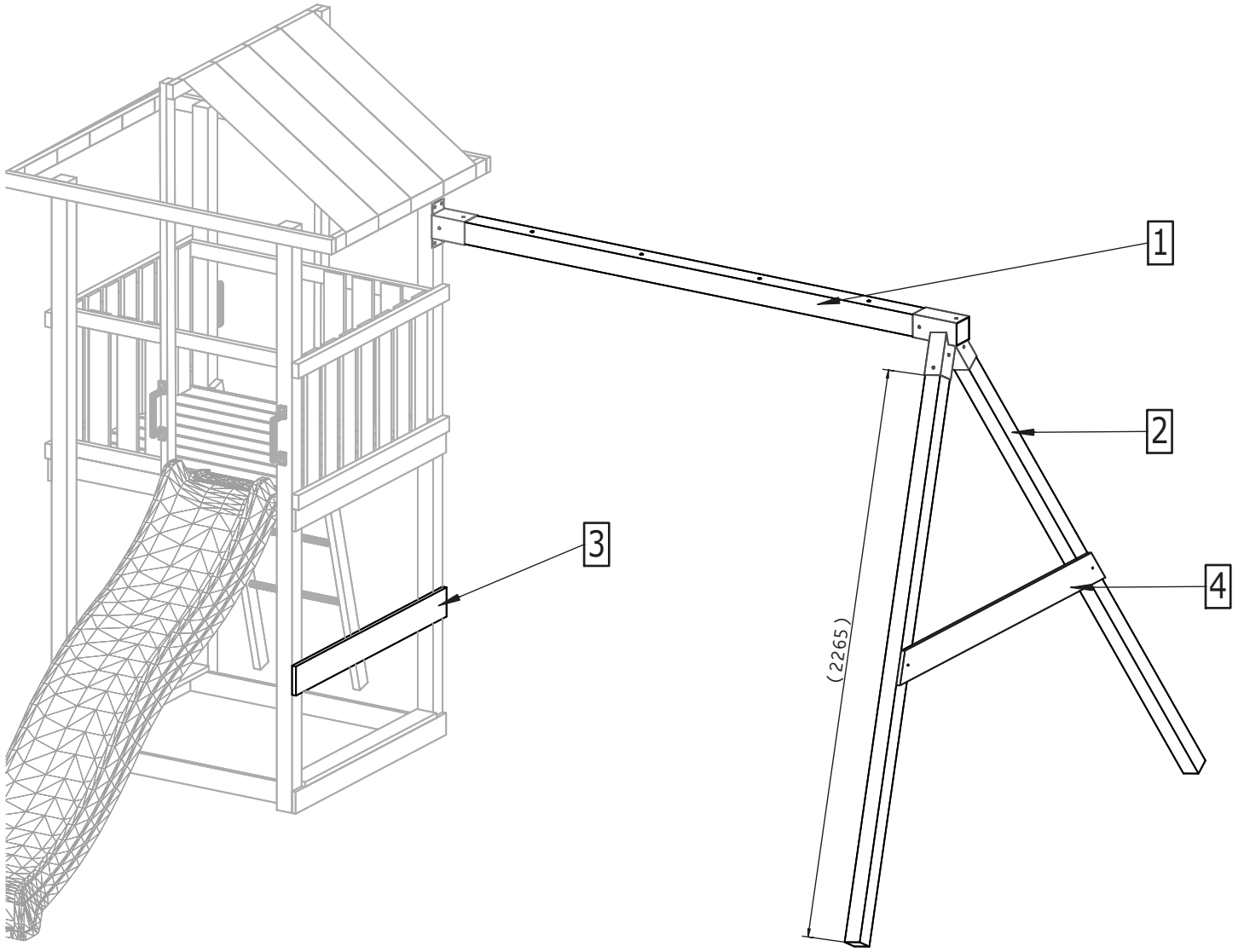

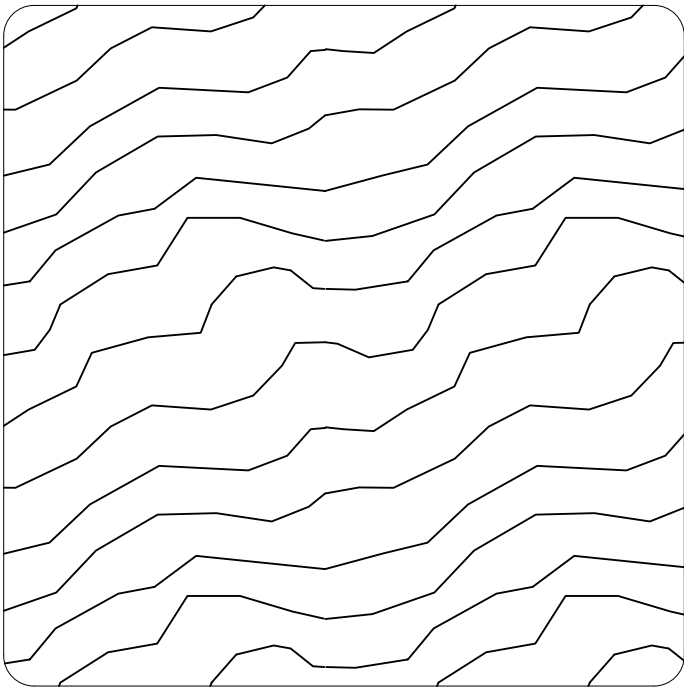

**9,0 x 9,0 cm**

Lp.	Wymiary [mm]	szt.
1a	90x90x2400mm	1

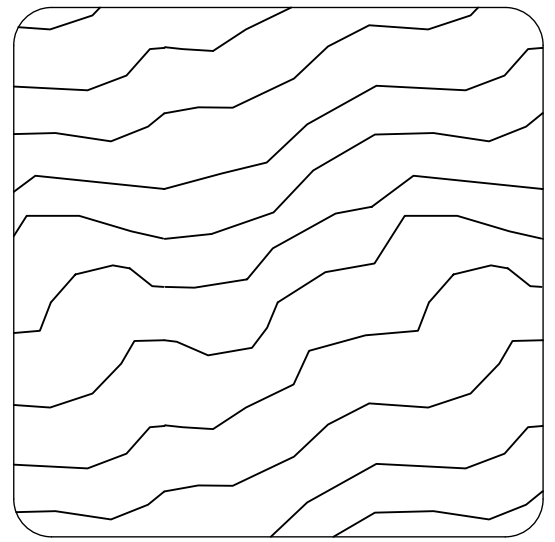

**7,0 x 7,0 cm**

Lp.	Wymiary [mm]	szt.
2	70x70x2400mm	2

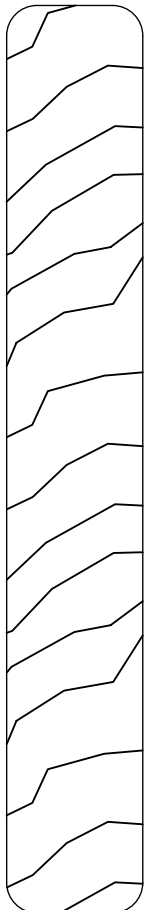

**1,8 x 12,0 cm**

Lp.	Wymiary [mm]	szt.
3	18x120x1600mm	1
4a	18x120x1500mm	1

1a

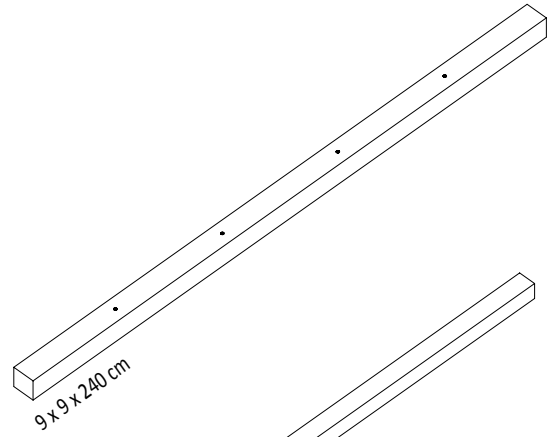

2

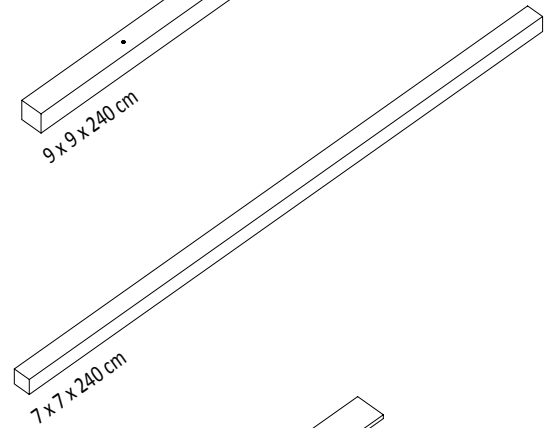

3

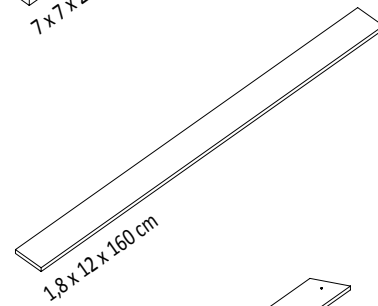

4a

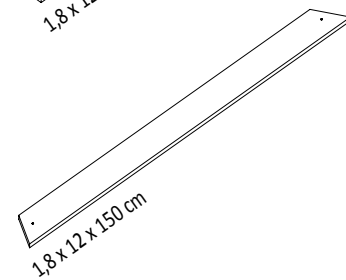

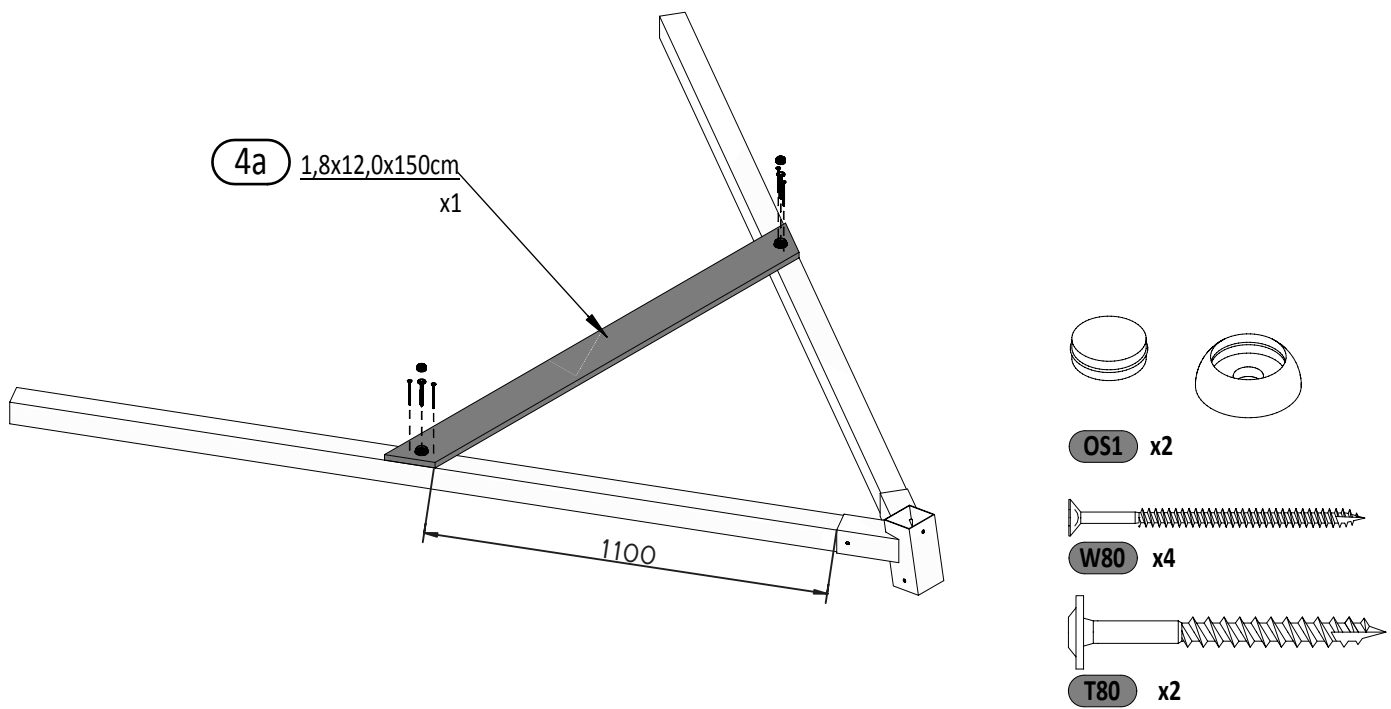
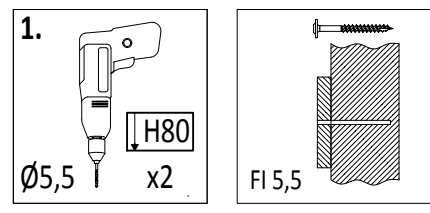
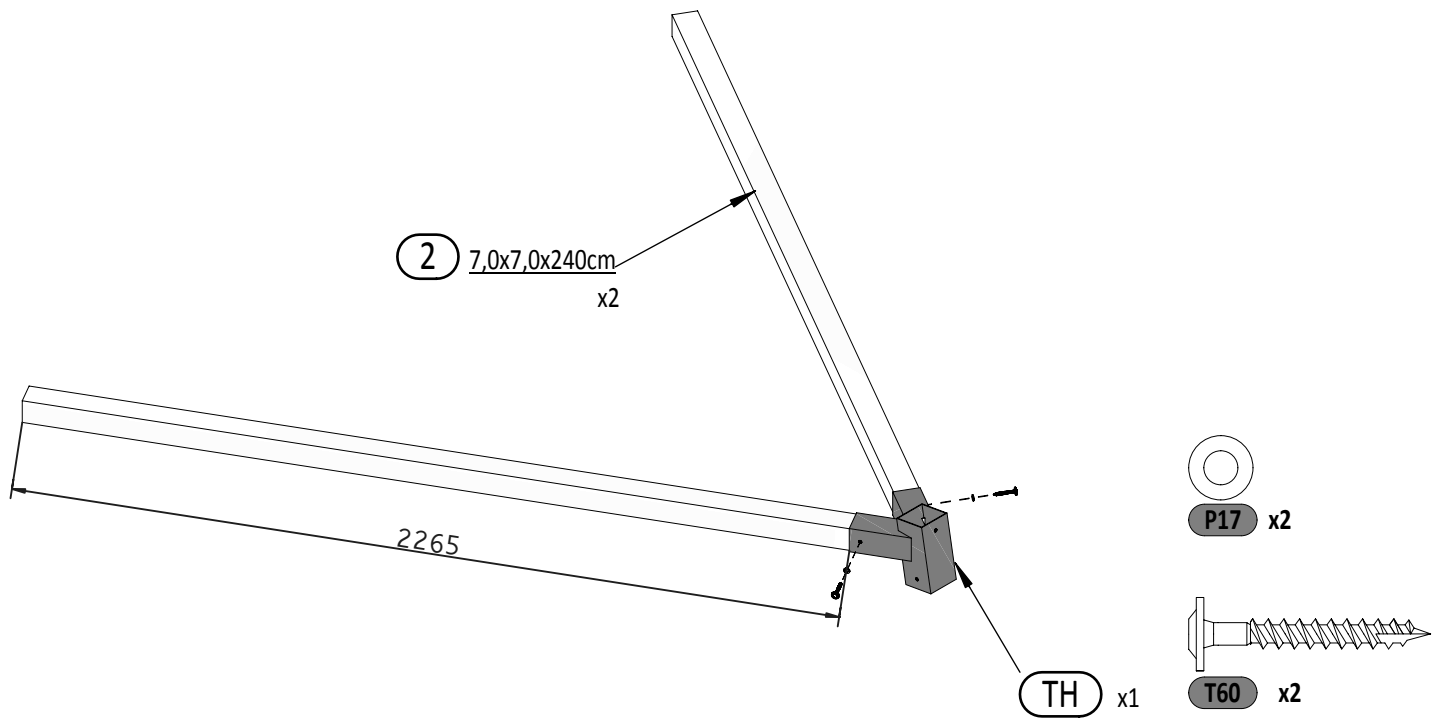

Zgodnie z normą PN-EN 71 stosuj zalecenia producenta odnośnie odległości oraz metody mocowania poszczególnych elementów  
 In compliance with the standard PN-EN 71, apply guidelines of the producer in relation to distances and methods of fastening individual elements

03

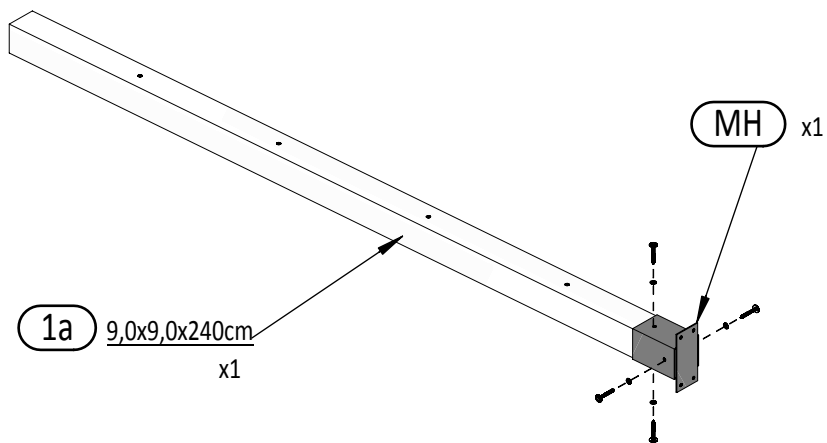

P17 x4



T60 x4

04

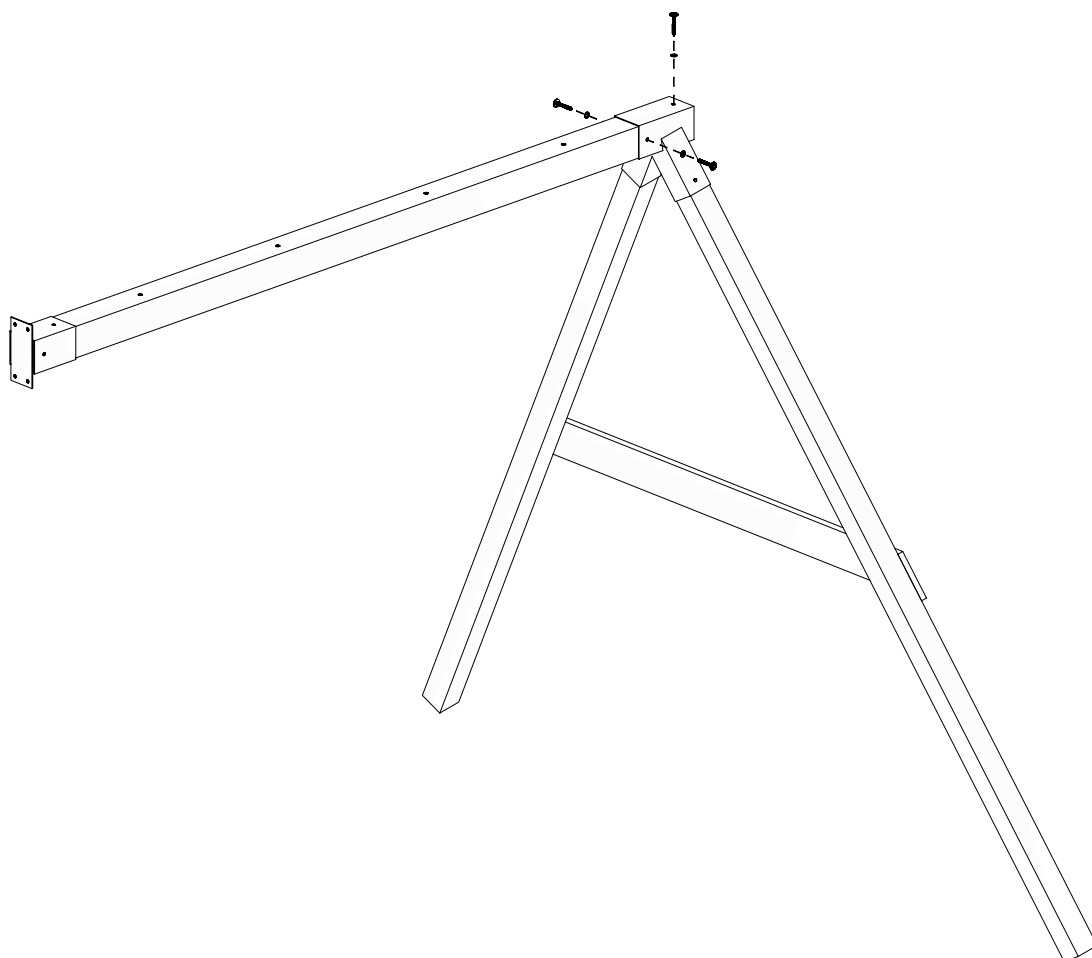

P17 x3

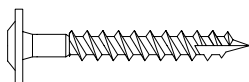

T60 x3

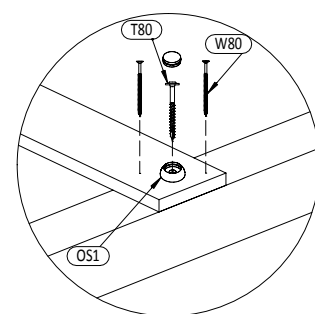
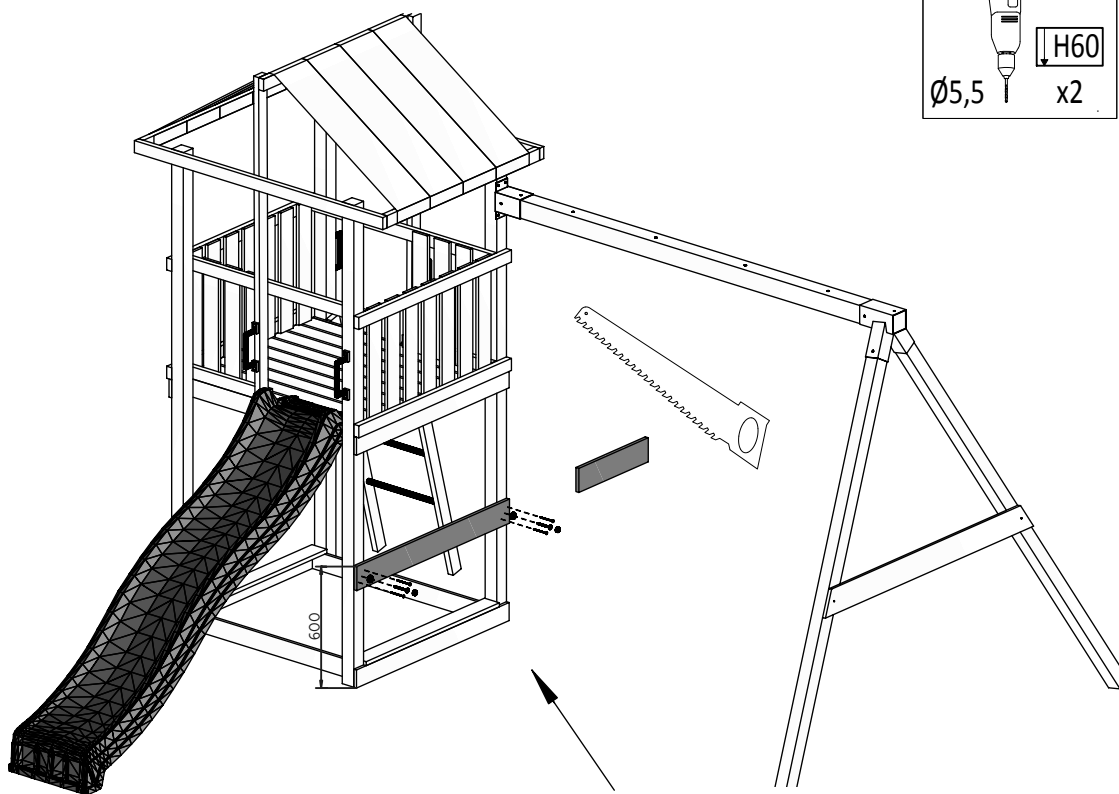
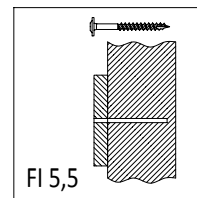
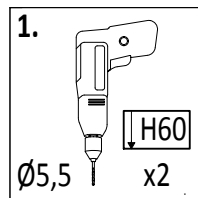
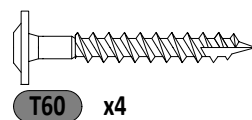
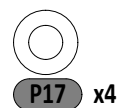
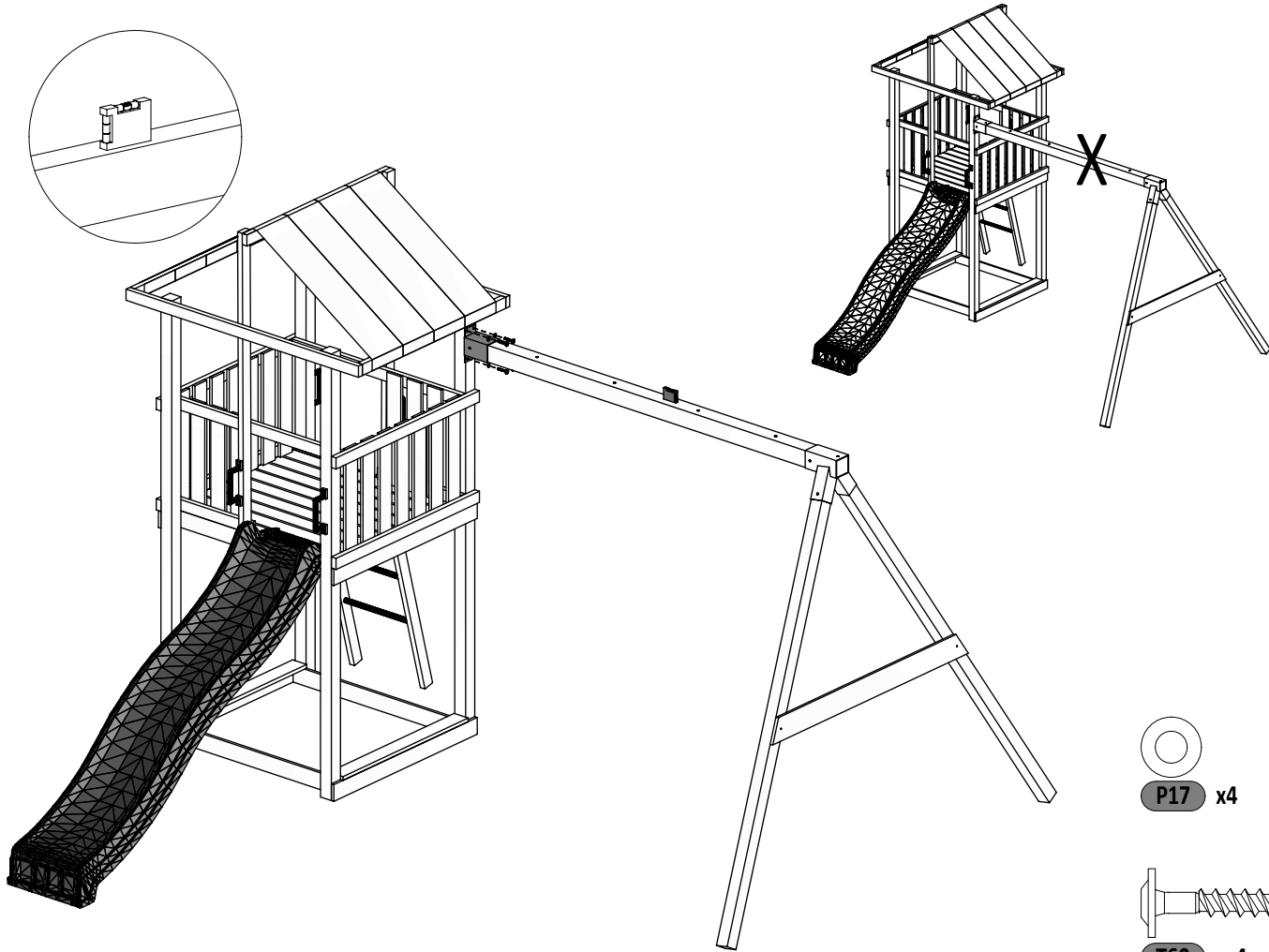

**OS1** x2

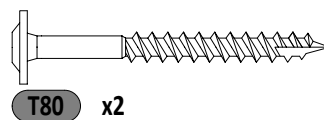

**3** 1,8x12,0x160cm  
x1



07

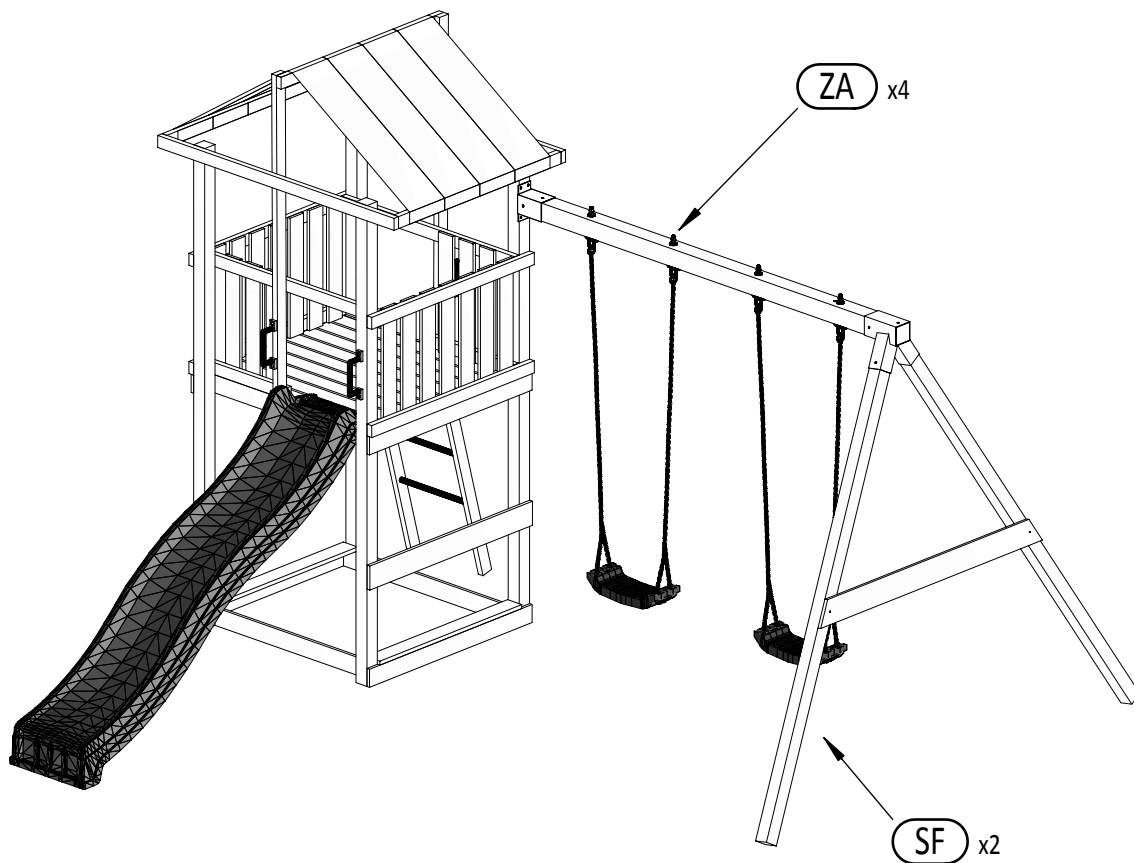

08

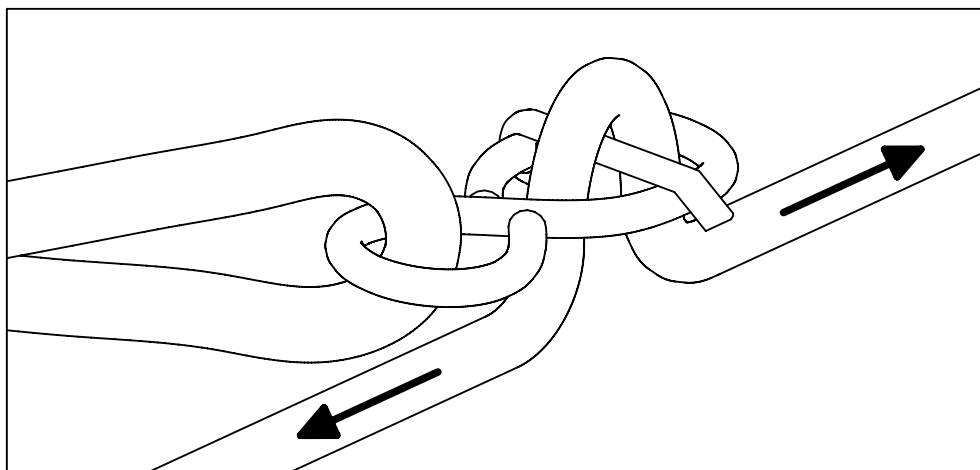

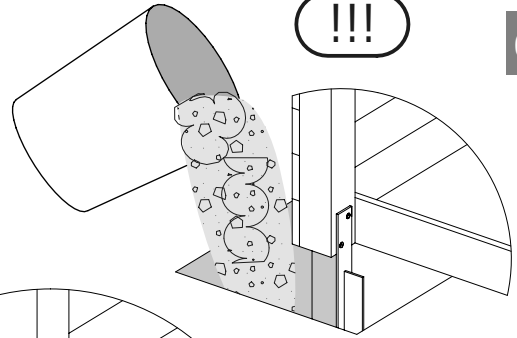
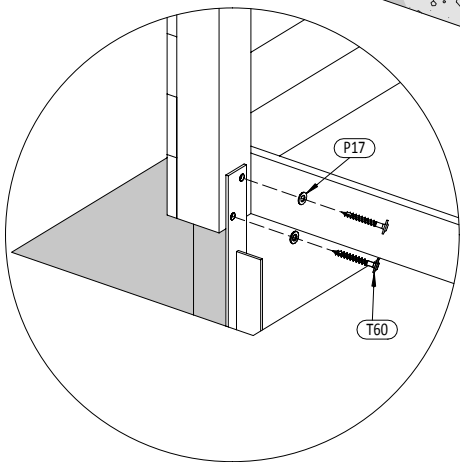
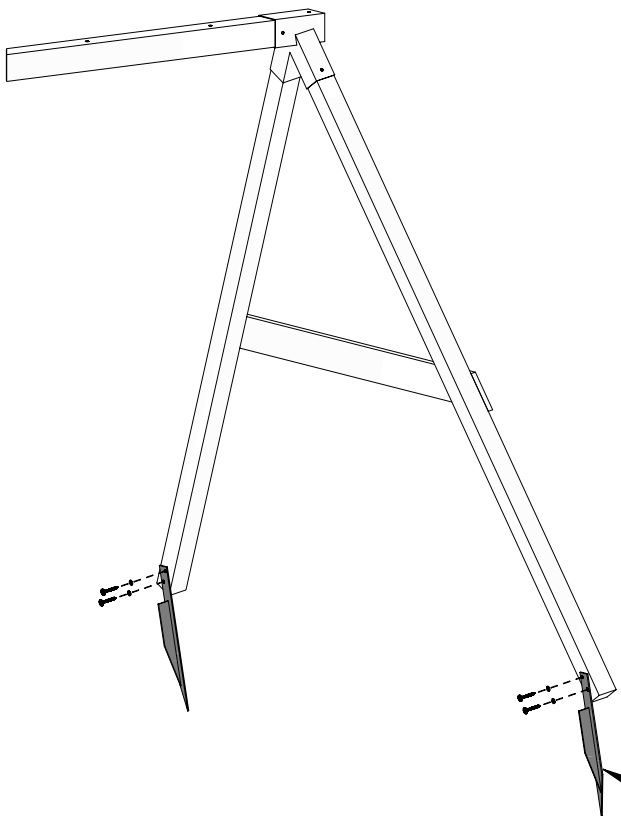

MG x2

P17 x4

T60 x4

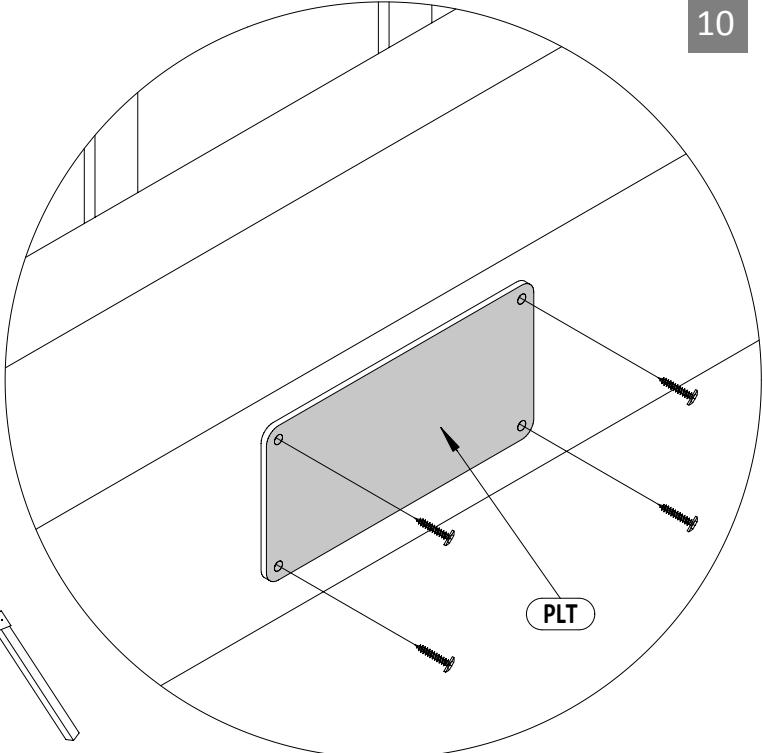
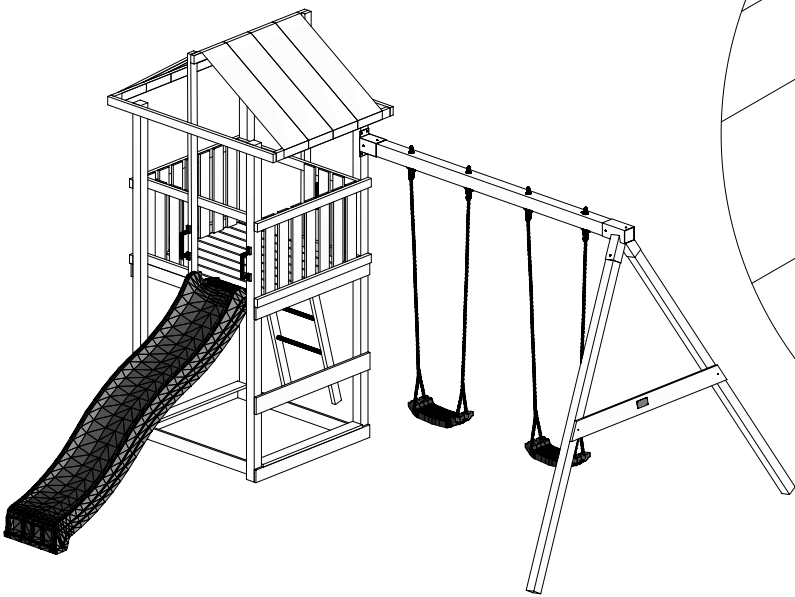

PLT

W20 x4

Zgodnie z normą PN-EN 71 stosuj zalecenia producenta odnośnie odległości oraz metody mocowania poszczególnych elementów  
In compliance with the standard PN-EN 71, apply guidelines of the producer in relation to distances and methods of fastening individual elements